

Low Voltage

# Interpact

Switch-disconnectors INS/INV40 to 2500 A

Catalogue  
2008

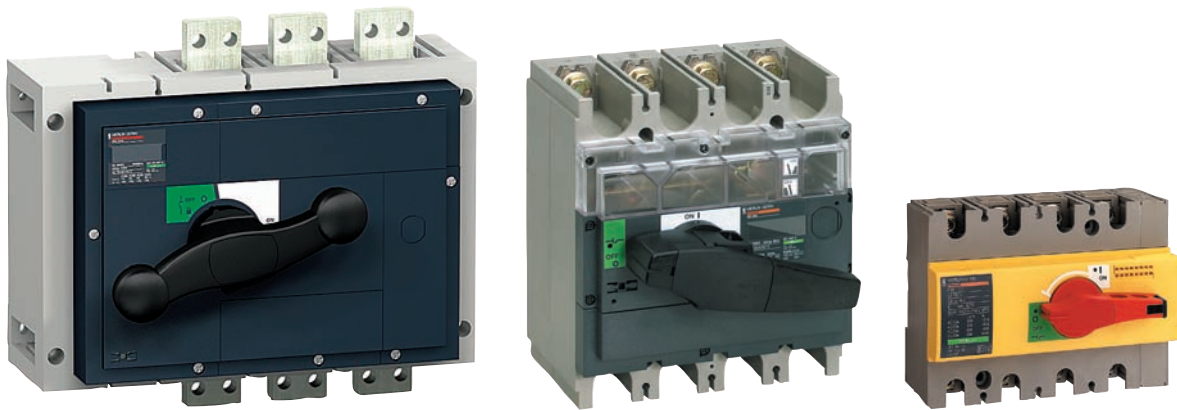



---

Presentation	2	
--------------	---	---

---

Functions and characteristics	A-1	
----------------------------------	-----	---

---

Installation recommendations	B-1	
---------------------------------	-----	---

---

Dimensions and connection	C-1	
------------------------------	-----	---

---

Additional characteristics	D-1	
----------------------------	-----	---

---

Catalogue numbers	E-1	
-------------------	-----	---

---

# Who else offers such from 40 to 2500 A?

## Interpact INS

Switch-disconnectors with positive contact indication



## Interpact INV

Switch-disconnectors with visible break



## Interpact INS

Emergency-off switch-disconnectors with positive contact indication



## Interpact INV

Emergency-off switch-disconnectors with visible break

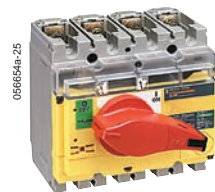

The complete range

40 A 63 A 80 A 100 A 125 A 160 A 200 A 250 A

Modular profile

INS40 INS63 INS80 INS100 INS125 INS160

INS250-100 INS250-160 INS250-200 INS250

Mounting on backplate

INV100 INV160 INV200 INV250

# ... in a wide range

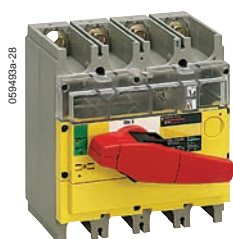
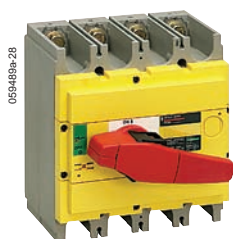
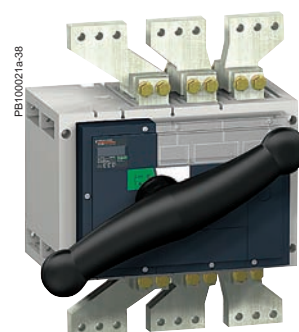
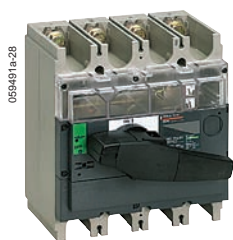
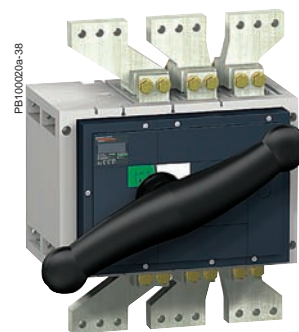
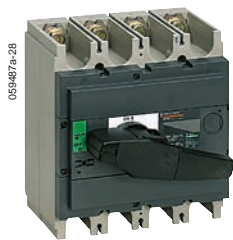

320 A    400 A    500 A    630 A    800 A    1000 A    1250 A    1600 A    2000 A    2500 A

INS320    INS400    INS500    INS630  
INS630b    INS800    INS1000    INS1250    INS1600    INS2000    INS2500

INV320    INV400    INV500    INV630  
INV630b    INV800    INV1000    INV1250    INV1600    INV2000    INV2500

# Who else covers



62278a-27

## Local isolation enclosures

- Current ratings: up to 63 A for commercial and 630 A for industrial applications
- Merlin Gerin switch-disconnectors
- NG125NA, Interpact INS40 to 160 and I modular switches
- Interpact INS/INV
- Compact NSA
- Telemecanique switch-disconnectors
- Vario 12 to 175 A.



E9208a-32\_150dpi

## Control panels

- Current ratings: up to 63/80 A
- Merlin Gerin switch-disconnectors: □ Interpact INS
- Telemecanique switch-disconnectors □ Vario.

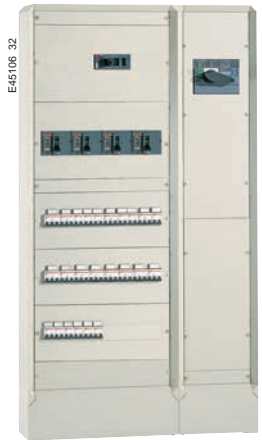

E45106-32

## Sub-distribution boards

- Current ratings: up to 160 A
- Merlin Gerin switch-disconnectors: □ Interpact INS/INV □ NG125.

DB1068Z1

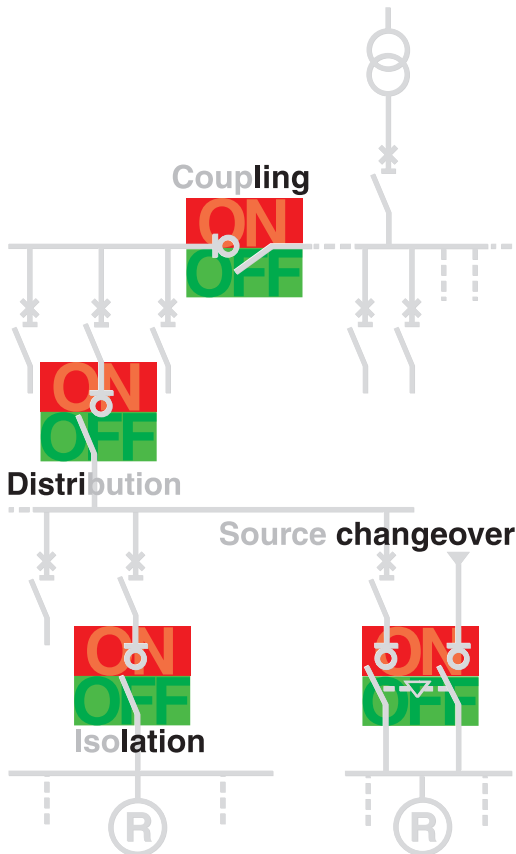

**Local isolation**  
Industrial or commercial

**Final distribution**

**Sub-distribution**

**Power distribution**

# so many applications?



## Industrial switchboards and automatic control panels

- Current ratings: up to 400 A
- Merlin Gerin switch-disconnectors:
  - Interpact INS/INV
  - Compact NSA.



## Main power distribution boards for commercial and industrial applications

- Current ratings:
  - 400 to 1000 A for commercial applications
  - 400 to 1600 A for industrial applications
- Merlin Gerin switch-disconnectors:
  - Interpact INS/INV
  - Compact NSA
  - Masterpact NA/HA/HA10/HF.

# Who else offers such

## INS/INV switch-disconnectors:



INS	INS40	INS63	INS80	INS100	INS125
<b>INV</b>					
<b>Ith at 60 °C</b>	40	63	80	100	125
<b>Ui CA 50/60 Hz/CC (V)</b>	690	690	690	750	750
<b>Uimp (kV)</b>	8	8	8	8	8

## INS/INV switch-disconnectors:



INS	INS40	INS63	INS80	INS100	INS125
<b>Ue AC22A 380/415 V</b>	40	63	80	100	125
<b>Ue AC22A 660/690 V</b>	-	-	-	100	125
<b>Ue AC23A 380/415 V</b>	40	63	72	100	125
<b>Ue AC23A 500/525 V</b>	32	40	40	100	125
<b>Ue AC23A 660/690 V</b>	-	-	-	63	80

- (1) 1600 A at 45 °C and 1450 A at 60 °C.
- (2) Ue AC22A / AC22B.
- (3) Ue AC22B.

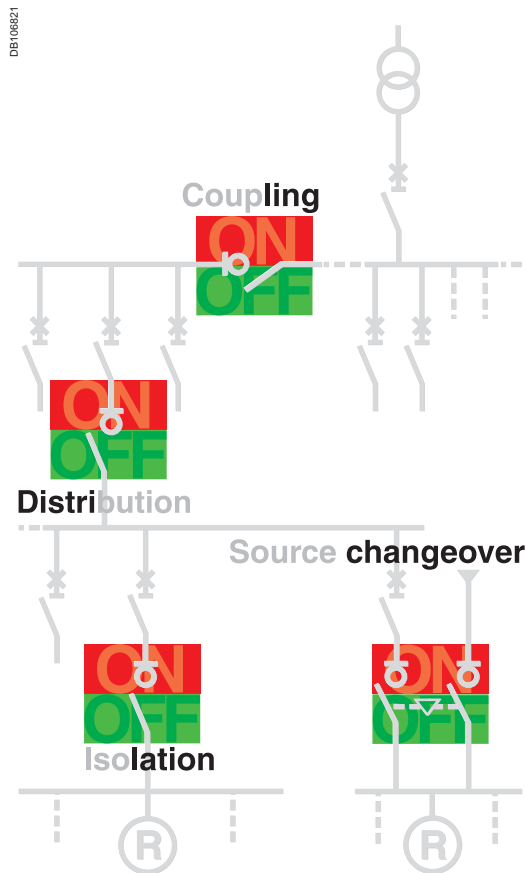

## Source changeover systems:

## Standards and certifications:



The Interpact INS/INV range complies with international standards, as officially certified by an independent organisation.

**IEC 60 947-1, IEC 60 947-3  
EN 60 947-1, EN 60 947-3**



### Conformity with UL and CSA standards

Special versions of Interpact switch-disconnectors are available that comply with UL and CSA standards for moulded case switches.

**UL489 and CSA C22.2 No. 5-02**



# high performances and safety?

## ... for high industrial performance

INS160	INS250-100	INS250-160	INS250-200	INS250	INS320	INS400	INS500	INS630	INS630b	INS800	INS1000	INS1250	INS1600	INS2000	INS2500
INV100	INV160	INV200	INV250	INV320	INV400	INV500	INV630	INV630b	INV800	INV1000	INV1250	INV1600	INV2000	INV2500	
160	100	160	200	250	320	400	500	630	630	800	1000	1250	1600 <sup>(1)</sup>	2000	2500
750	750	750	750	750	750	750	750	750	750	1000	1000	1000	1000	1000	1000
8	8	8	8	8	8	8	8	8	12	12	12	12	12	12	12

## ... for maximum operational voltage

INS160	INS250-100	INS250-160	INS250-200	INS250	INS320	INS400	INS500	INS630	INS630b	INS800	INS1000	INS1250	INS1600	INS2000	INS2500
160	100	160	200	250	320	400	500	630	630	800	1000	1250	1450/1600 <sup>(2)</sup>	2000 <sup>(3)</sup>	2500 <sup>(3)</sup>
160	100	160	200	250	320	400	500	630	630	800	1000	1250	1250/1600 <sup>(2)</sup>	2000 <sup>(3)</sup>	2500 <sup>(3)</sup>
160	100	160	200	250	320	400	500	630	630	800	1000	1250	1250	-	-
160	100	160	200	250	320	400	500	630	630	800	1000	1250	1250	-	-
100	100	160	200	250	320	400	500	630	630	800	1000	1250	1250	-	-
Identical performance up to 500/690 V															

## ... from 100 to 630 A, with identical performance

- The entire range has been fully certified IEC 60947-1, IEC 60947-3 and EN 60947-1, EN 60947-3. Certification was carried out within the framework of the LOVAG agreement by independent certification organisations
- Marine certification is underway

- Certain ratings are UL listed (UL 489 listed for the switch part) for markets requiring such certification.

# Designed to work

## INS for positive contact indication and INV for visible break

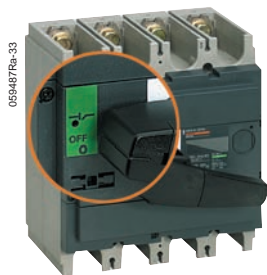

0594487Ra-33

A mechanical system ensures that the position of the handle always reflects the position of the main contacts. With positive contact indication, Schneider Electric guarantees optimum safety for all users of the Interpact range.

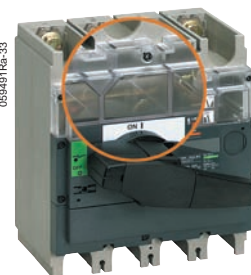

0594019Ra-33

The physical separation of the main contacts is directly visible through a transparent cover. With this visible break function in addition to positive contact indication, the Interpact INV range offers double safety.

## Rotary, front and lateral handles... a very wide choice.

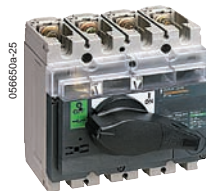

0566550a-25



E82076a-34



056660a-27

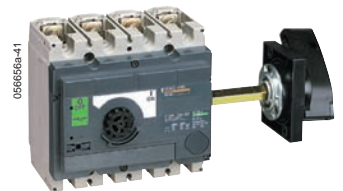

056656a-41

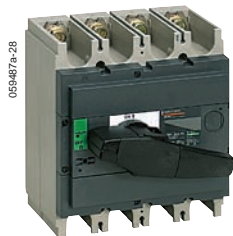

0594487a-28



059465a-33

## Specially design handles for easy operation



PF100016a-47

The interruption of current flowing in high-power circuits is associated with high mechanical forces within small volumes.

To facilitate the operation of the Interpact range of switch-disconnectors, Schneider Electric has paid particular attention to the design of the handles. As a result, the Interpact range offers both high performance and easy operation.

## One-piece spreader



INS and INV devices may be equipped with a spreader corresponding to the pitch of the terminals of the next highest frame size, just like Compact NS devices. This one-piece spreader offers improved accessibility and ensures a uniform electrical installation. It may be fitted with all the connection and isolation accessories of the Compact NS device with the next highest frame size.

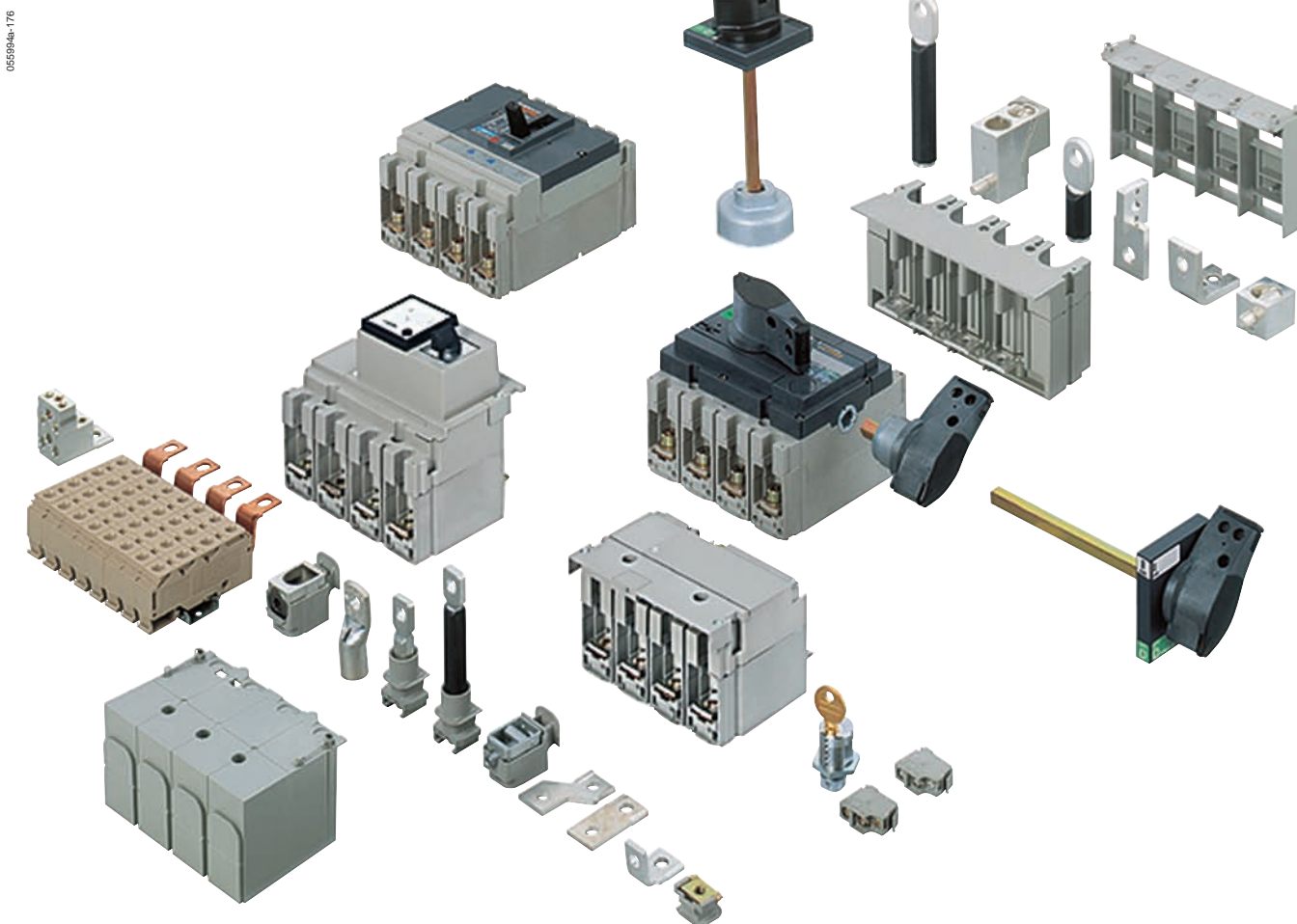

# Manual source-changeover systems:

- Easy installation
- Built-in safety
- Automatic interlocking
- Simple operating mechanism

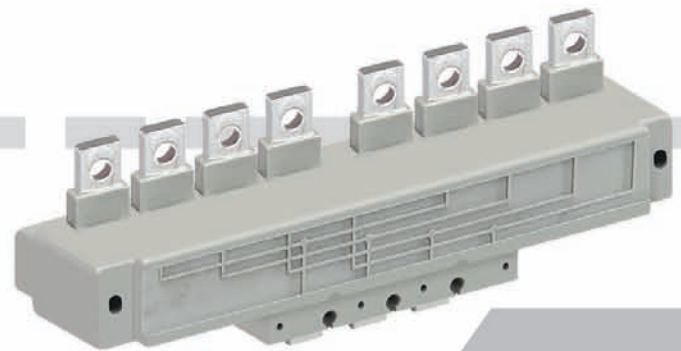
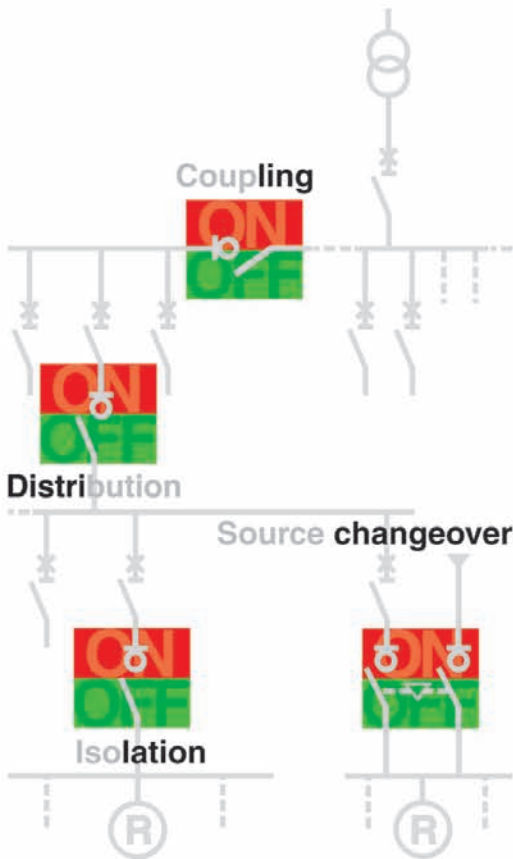

Coupler

# solutions for continuous performance

The complete source-changeover assembly makes it possible to transfer between a normal source (N) and a replacement source (R) using a single operating handle

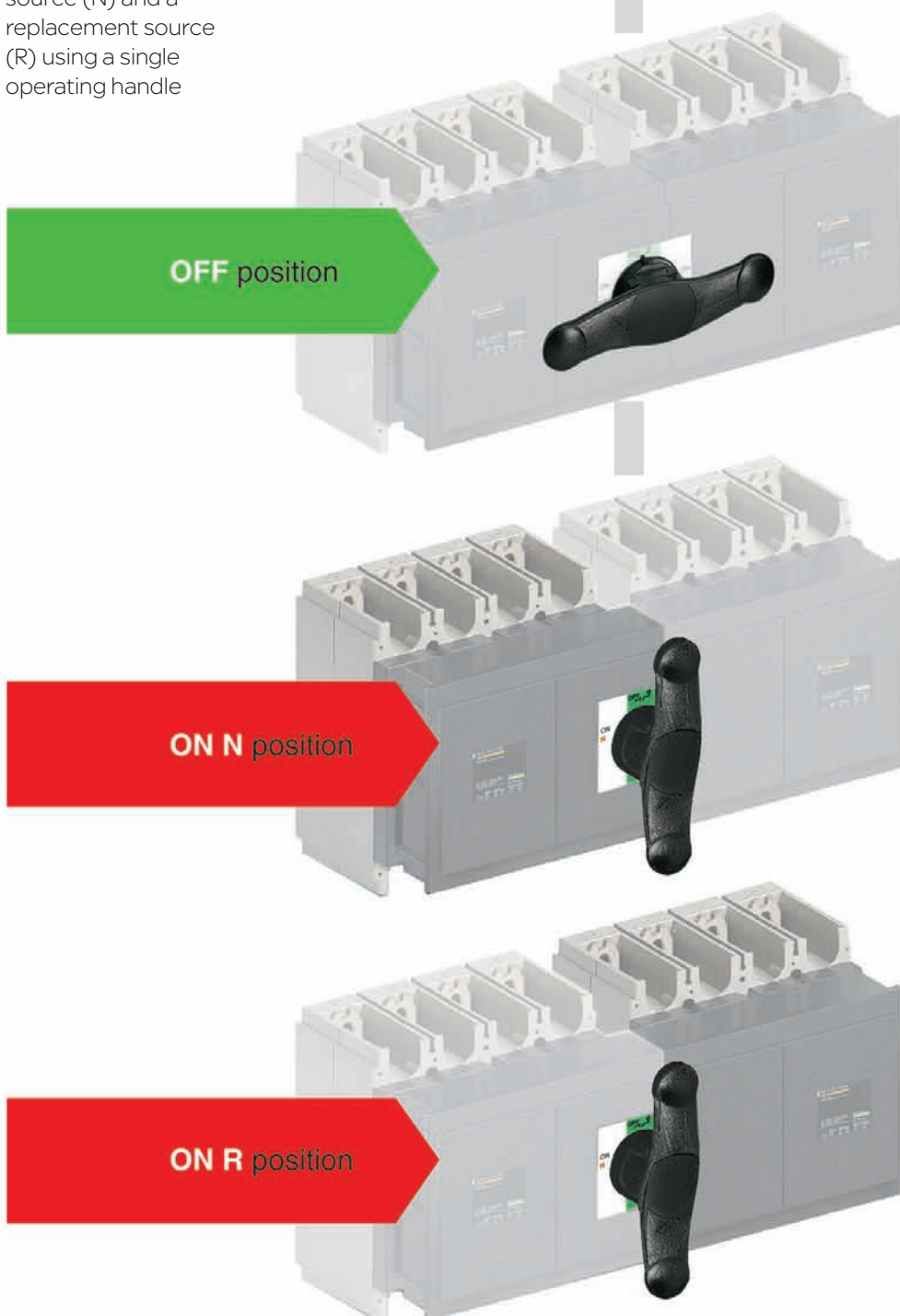

# A complete offering

DE117444

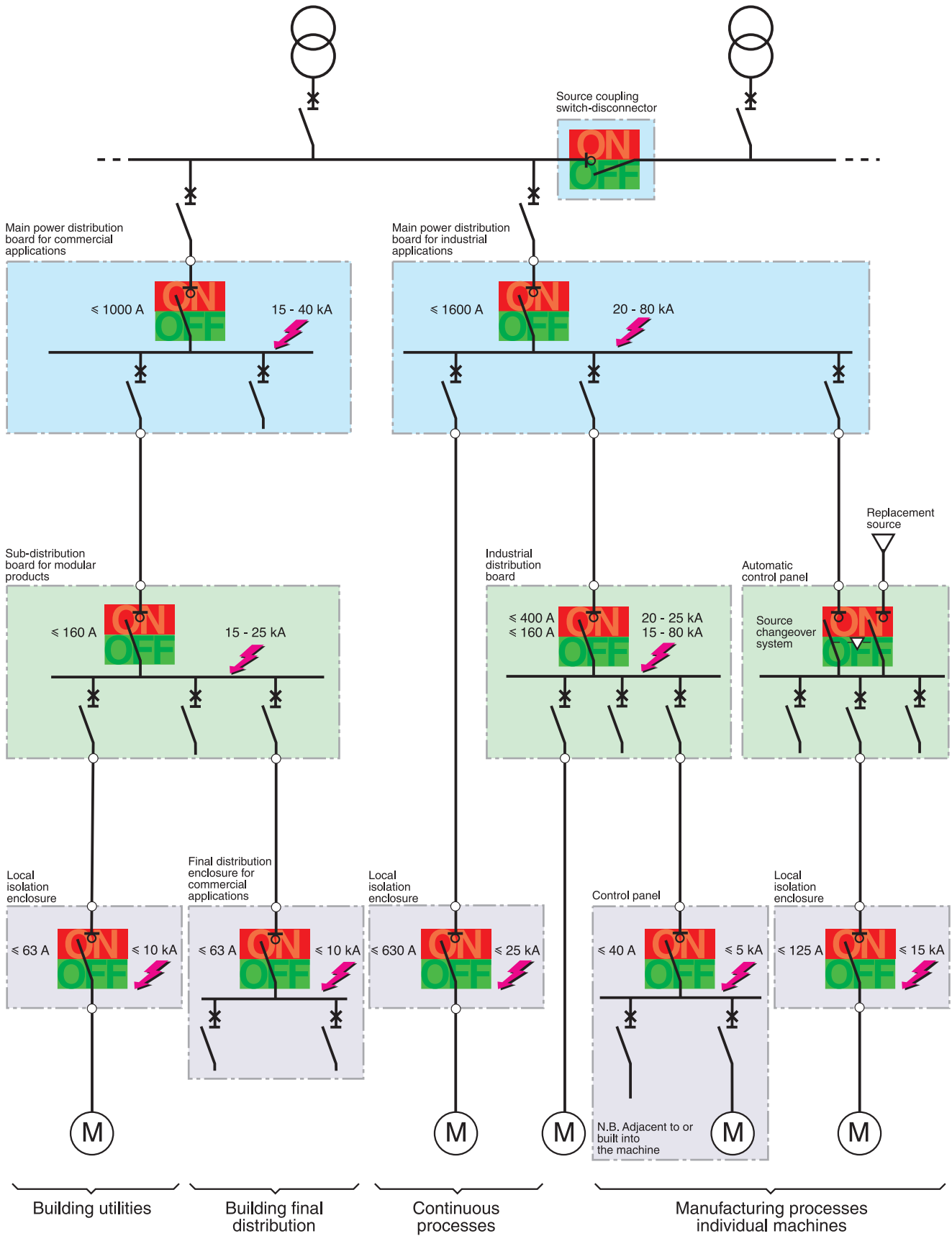

for all your needs

## Power distribution incomers and coupling devices



Masterpact NW25HA.



Interpact INS2000.



Compact NS1600NA.

## Sub-distribution incomers



Compact NSX400NA.



Compact NS400NA.



Interpact INS630 complete source-changeover assembly.



Interpact INV400.



NG125.

## Final distribution outgoers and local isolation and control devices



Compact NSX250NA.



Compact NS250NA.



Interpact INV250.



NG125.



Interpact INS80.



Vario.

Multi 9.

## schneider-electric.com

This international site allows you to access all the Schneider Electric products in just 2 clicks via comprehensive range data-sheets, with direct links to:

- complete library: technical documents, catalogs, FAQs, brochures...

- selection guides from the e-catalog.

- product discovery sites and their Flash animations.

You will also find illustrated overviews, news to which you can subscribe, the list of country contacts...



## The technical guide

These technical guides help you comply with installation standards and rules i.e.: the electrical installation guide, the protection guide, the switchboard implementation guide, the technical booklets and the co-ordination tables all form genuine reference tools for the design of high performance electrical installations.





For example, the LV protection co-ordination guide - discrimination and cascading - optimises choice of protection and connection devices while also increasing markedly continuity of supply in the installations.



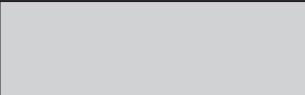

<i>Presentation</i>	2
<b>General characteristics</b>	<b>A-2</b>
<b>Switch-disconnector selection</b>	<b>A-6</b>
Interpact INS40 to 160	A-6
Interpact INS250-100 to 630	A-10
Interpact INS630b to 2500	A-14
Interpact INV100 to 630	A-18
Interpact INV630b to 2500	A-23
<b>Complete source-changeover assembly selection</b>	<b>A-26</b>
Interpact INS250-100 to 630	A-26
<b>Switch-disconnector selection</b>	<b>A-30</b>
Interpact INS40 to 80	A-30
Interpact INS100 to 160	A-31
Interpact INS250-100 to 630	A-32
Interpact INV100 to 630	A-32
Interpact INS320 to 630	A-33
Interpact INV320 to 630	A-33
Interpact INS630b to 1600	A-34
Interpact INV630b to 1600	A-34
Interpact INS2000 to 2500	A-35
Interpact INV2000 to 2500	A-35
<b>Electrical and mechanical accessories</b>	<b>A-36</b>
<b>Manual source-changeover systems</b>	<b>A-40</b>
<b>Connection accessories</b>	<b>A-42</b>
<b>Installation</b>	<b>A-52</b>
<i>Installation recommendations</i>	B-1
<i>Dimensions and connection</i>	C-1
<i>Additional characteristics</i>	D-1
<i>Catalogue numbers</i>	E-1

DB105442

																			
																			
<b>INS 250</b>																			
																			
<b>Ui 750V Uimp 8kV</b> lth 250A 60°C	<b>IEC 947.3</b> 																		
<table border="1"> <tr> <td></td> <td><b>AC22A</b></td> <td><b>AC23A</b></td> <td></td> </tr> <tr> <td>Ue(V)</td> <td>690</td> <td>500 690</td> <td></td> </tr> <tr> <td>Ie (A)</td> <td>250</td> <td>250 250</td> <td></td> </tr> </table>		<b>AC22A</b>	<b>AC23A</b>		Ue(V)	690	500 690		Ie (A)	250	250 250		<b>DC23A (2/4PS)</b> CEI UTE UNE VDE BS <table border="1"> <tr> <td></td> <td>125<sub>(2P)</sub></td> <td>250<sub>(4P)</sub></td> </tr> <tr> <td></td> <td>250</td> <td>250</td> </tr> </table>		125 <sub>(2P)</sub>	250 <sub>(4P)</sub>		250	250
	<b>AC22A</b>	<b>AC23A</b>																	
Ue(V)	690	500 690																	
Ie (A)	250	250 250																	
	125 <sub>(2P)</sub>	250 <sub>(4P)</sub>																	
	250	250																	

*lth* : conventional thermal current.  
*Ui* : rated insulation voltage.  
*Uimp* : rated impulse-withstand voltage.  
*Ue* : rated operational voltage.  
*Ie* : rated operational current.  
 suitable for isolation.

### Conformity with standards

Interpact switch-disconnectors and auxiliaries comply with the following standards and international recommendations:

- IEC 60947-1: general rules
- IEC 60947-3: switches, disconnectors, switch-disconnectors, etc.
- IEC 60947-5.1 and following: control-circuit devices and switching elements; automatic-control components.

In that these standards and recommendations are applied in most countries, Interpact switch-disconnectors and auxiliaries comply with European (EN 60947-1, EN 60947-3, EN 60947-5-1) and the corresponding national standards:

- France NF
- Germany VDE
- United Kingdom BS
- Australia AS
- Italy CEI.

Interpact switch-disconnectors are suitable for the control of machine-tools in that they comply with French standard NF C 79-130 and with the recommendations issued by the CNOMO organisation.

### Installation in class II switchboards

All Interpact INS and INV switch-disconnectors are class II front-face devices. They may be installed through the door of class II switchboards (as per standard IEC 60664) without downgrading switchboard insulation. Installation requires no special operations even when the switch-disconnector is equipped with rotary handles.

### Environmental withstand capacity (tropicalisation)

Interpact INS/INV switch-disconnectors meet the environmental requirements of the following standards:

- IEC 60068-2-1 - dry cold (-55 °C)
- IEC 60068-2-1 - dry heat (+85 °C)
- IEC 60068-2-30 - damp heat (95 % relative humidity at +55 °C)
- IEC 68-2-52 (level 2) - salt mist.

### Degree of pollution

The Interpact range is certified for operation in pollution-degree 3 environments as defined by IEC standard 60947 for industrial environments.

### Ambient temperature

#### Operating-temperature range

- Interpact INS and INV switch-disconnectors may be used between -25 °C and +70 °C
- Switch-disconnectors should be put into service under the normal, ambient operating temperatures indicated above. Exceptionally, they may be put into service when the ambient temperature is between -35 °C and -25 °C.

#### Storage-temperature range

Interpact INS and INV switch-disconnectors may be stored in their original packing between -50 °C and +85 °C.

### Environmental protection

Interpact INS and INV switch-disconnectors take into account important concerns for environmental protection. Most components are recyclable. Insulating parts making up the Interpact INS and INV switch-disconnectors are marked as specified in applicable environmental standards.

## Altitude

Interpact INS and INV switch-disconnectors are designed to operate at their rated values at altitudes under 2000 metres.

Above 2000 metres, the changes in the characteristics of the ambient air (electrical resistance, cooling capacity) result in a reduction of the characteristics below.

Altitude (m)	2000	3000	4000	5000
Dielectric resistance voltage (V)	3500	3150	2500	2100
Rated insulation voltage (V)	750	700	600	500
Maximum utilisation voltage (V)	690	550	480	420
Rated current (A) at 60 °C	1 x In	0.96 In	0.93 In	0.9 In

## Vibrations

Interpact INS and INV switch-disconnectors are guaranteed against electromagnetic or mechanical vibrations.

Tests are carried out in compliance with standard IEC 68-2-6 for the levels required by merchant-marine inspection organisations (Veritas, Lloyd's, etc.):

- 2 to 13.2 Hz: amplitude ±1 mm
- 13.2 to 100 Hz: constant acceleration 0.7 g.

Excessive vibration may cause tripping, breaks in connections or damage to mechanical parts.

## Electromagnetic compatibility

Interpact INS and INV switch-disconnectors are protected against:

- overvoltages caused by devices that generate electromagnetic disturbances
- overvoltages caused by atmospheric disturbances or by a distribution-system outage (e.g. failure of a lighting system) and devices emitting radio waves (radios, walkie-talkies, radar, etc.).

Interpact INS and INV switch-disconnectors comply with the following electromagnetic-compatibility standards:

- IEC/EN 61000-4-2 - electrostatic immunity discharge test
- IEC/EN 61000-4-3 - electromagnetic-field immunity test
- IEC/EN 61000-4-4 - electrical fast transient/burst immunity test
- IEC/EN 61000-4-5 - surge immunity test
- IEC/EN 61000-4-6 - immunity to conducted disturbances, induced by radiofrequency fields
- CISPR 11 - radio-frequency conducted and radiated emission tests required for CE marking
- EN 61000-6-2 - immunity standard for industrial environments
- EN 50081-1-2 - emissions in commercial and industrial environments.

## Degree of protection

Interpact INS and INV switch-disconnectors offer the following protection characteristics depending on the installation conditions:

- IP: degree of protection (standard IEC 60529)
- IK: protection against external mechanical impacts (standard EN 50102).

### IP40 IK07

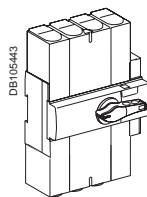

*Bare switch-disconnector with terminal shields.*

### IP40 IK07

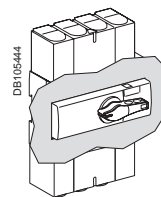

*Switch-disconnector in cabinet or enclosure (direct handle).*

### IP55 IK08

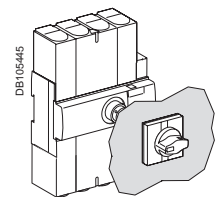

*Switch-disconnector in cabinet or enclosure (extended handle).*



Suitable for isolation with positive contact indication.

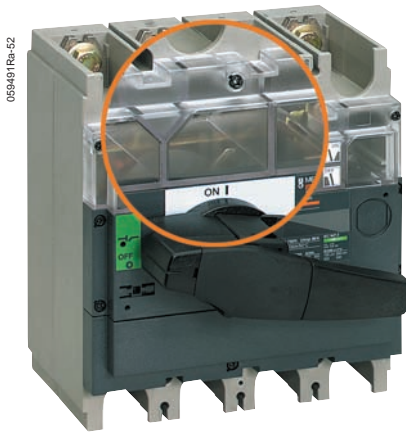

Suitable for isolation with visible break.



INS250 emergency-off switch-disconnector.



INV250 emergency-off switch-disconnector.

## Suitable for isolation with positive contact indication



All Interpact switch-disconnectors are suitable for isolation as defined in IEC standards 60947-1 and 3:

- The isolation position corresponds to the O (OFF) position
- The operating handle cannot indicate the OFF position unless the contacts are actually open
- Padlocking in the OFF position is not possible unless the contacts are actually open.

Installation of an extended handle does not alter the suitability for isolation. The isolation function is certified by tests guaranteeing:

- The mechanical reliability of the position-indication system
- The absence of leakage currents
- Overvoltage withstand capacity between upstream and downstream connections.

## Suitable for isolation with visible break

The physical separation of the main contacts is directly visible through a transparent cover.

The Interpact INV range offers both positive contact indication and visible break.

## Emergency-off switch disconnecter

This switch-disconnector can be used as an emergency-off device. For this application, it must be easily visible, accessible and identifiable (see standards and rules concerning the safety of machines VDE 0660, VDE 0113, CNOMO, etc.).

For easy identification, the emergency-off switch-disconnector uses special colours stipulated by the standards and different from those of the standard version:

- Yellow for the front face of the device
- Red for the handle.

The electrical and mechanical performance characteristics of Interpact emergency-off switch-disconnector are the same as those of the standard version.

The emergency-off switch-disconnectors are available in positive contact indication and visible-break versions.

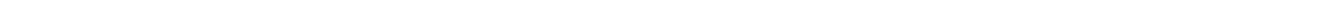

# Switch-disconnector selection

## Interpact INS40 to 160



Interpact INS80 switch-disconnector.



Interpact INS40 emergency-off switch-disconnector.



Interpact INS160 switch-disconnector.



Interpact INS160 emergency-off switch-disconnector.

### Interpact INS switch-disconnectors

Number of poles

#### Electrical characteristics as defined by IEC 60947-1 / 60947-3 and EN 60947-1 / 60947-3

Conventional thermal current (A)	<b>I<sub>th</sub></b>	at 60 °C
Conventional thermal current in enclosure	<b>I<sub>the</sub></b>	at 60 °C
Rated insulation level (V)	<b>U<sub>i</sub></b>	AC 50/60 Hz
Impulse-withstand voltage (kV)	<b>U<sub>imp</sub></b>	
Rated operational voltage (V)	<b>U<sub>e</sub></b>	AC 50/60 Hz DC
Rated operational voltage AC20 and DC20 (V)		AC 50/60 Hz
Rated operational current (A)	<b>I<sub>e</sub></b>	<b>Electrical AC 50/60 Hz</b>

220-240 V  
380-415 V  
440-480 V <sup>(1)</sup>  
500 V  
660-690 V

#### Electrical DC

125 V (2P in series)  
250 V (4P in series)

Rated operational power AC23 (kW)

#### Electrical AC 50/60 Hz

220-240 V  
230 V (NEMA)  
380-415 V  
440 V  
480 V (NEMA)  
500-525 V  
660-690 V

Rated duties

Uninterrupted duty  
Intermittent duty

Short-circuit making capacity (kA peak)

**I<sub>cm</sub>** Min. (switch-disconnector alone)  
Max. (with upstream protection circuit breaker)

Short-time withstand current (A rms)

**I<sub>cw</sub>** 1 s  
3 s  
20 s  
30 s

Suitability for isolation

Durability (O-C cycles)

Mechanical

**Electrical AC 50/60 Hz**  
220-240 V  
380-415 V  
440 V  
500 V  
690 V

#### Electrical DC

250 V

Positive contact indication

Visible break

Emergency-off switch disconnector

Degree of pollution

#### Upstream protection

See the "Additional characteristics" page D-1.

<sup>(1)</sup> Suitable for 480 V NEMA.

# Switch-disconnector selection

## Interpact INS40 to 160

INS40		INS63		INS80		INS100		INS125		INS160	
3-4		3-4		3-4		3-4		3-4		3-4	
40		63		80		100		125		160	
40		63		80		100		125		160	
690		690		690		750		750		750	
8		8		8		8		8		8	
500		500		500		690		690		690	
250		250		250		250		250		250	
690		690		690		750		750		750	
AC22A	AC23A	AC22A	AC23A	AC22A	AC23A	AC22A	AC23A	AC22A	AC23A	AC22A	AC23A
40	40	63	63	80	80	100	100	125	125	160	160
40	40	63	63	80	72	100	100	125	125	160	160
40	40	63	63	80	63	100	100	125	125	160	160
40	32	63	40	80	40	100	100	125	125	160	160
-	-	-	-	-	-	100	63	125	80	160	100
DC22A	DC23A	DC22A	DC23A	DC22A	DC23A	DC22A	DC23A	DC22A	DC23A	DC22A	DC23A
40	40	63	63	80	80	100	100	125	125	160	160
40	40	63	63	80	80	100	100	125	125	160	160
11	15	22	22	37	45	55	75	90	110	160	160
7,5	15	15	22	37	45	55	75	90	110	160	160
20	30	37	45	55	75	90	110	160	160	160	160
22	30	37	55	75	90	110	160	160	160	160	160
22	30	30	55	75	90	110	160	160	160	160	160
18,5	22	22	55	75	90	110	160	160	160	160	160
-	-	-	55	75	90	110	160	160	160	160	160
■	■	■	■	■	■	■	■	■	■	■	■
Class 120 - 60 %		Class 120 - 60 %		Class 120 - 60 %		Class 120 - 60 %		Class 120 - 60 %		Class 120 - 60 %	
15		15		15		20		20		20	
75		75		75		154		154		154	
3000		3000		3000		5500		5500		5500	
1730		1730		1730		3175		3175		3175	
670		670		670		1230		1230		1230	
550		550		550		1000		1000		1000	
■		■		■		■		■		■	
20000		20000		20000		15000		15000		15000	
AC22A	AC23A	AC22A	AC23A	AC22A	AC23A	AC22A	AC23A	AC22A	AC23A	AC22A	AC23A
1500	1500	1500	1500	1500	1500	1500	1500	1500	1500	1500	1500
1500	1500	1500	1500	1500	1500	1500	1500	1500	1500	1500	1500
1500	1500	1500	1500	1500	1500	1500	1500	1500	1500	1500	1500
1500	1500	1500	1500	1500	1500	1500	1500	1500	1500	1500	1500
-	-	-	-	-	-	1500	1500	1500	1500	1500	1500
DC22A	DC23A	DC22A	DC23A	DC22A	DC23A	DC22A	DC23A	DC22A	DC23A	DC22A	DC23A
1500	1500	1500	1500	1500	1500	1500	1500	1500	1500	1500	1500
■	■	■	■	■	■	■	■	■	■	■	■
-	-	-	-	-	-	-	-	-	-	-	-
■	■	■	■	■	■	■	■	■	■	■	■
3	3	3	3	3	3	3	3	3	3	3	3
-	-	-	-	-	-	-	-	-	-	-	-

# Switch-disconnector selection

## Interpact INS40 to 160

### Interpact INS switch-disconnectors

#### Installation

Fixed, front connection  
 Fixed, rear connection  
 On symmetrical rails  
 On a backplate

#### Connection

By cables	To bare cable connectors
By cables with lugs	Directly to terminals
	To spreaders
	To vertical-connection adapters via cable-lug adapters
Flat-facing bars	Directly to terminals
	To spreaders
Edgewise bars	To vertical-connection adapters

#### Indication and measurement auxiliaries

Auxiliary contacts  
 Voltage-presence indicator  
 Current-transformer module  
 Ammeter module

#### Control, locking and interlocking

Control	Direct front rotary handle
	Extended front rotary handle
	Direct lateral rotary handle
	Extended lateral rotary handle
Locking	By keylock
	By padlocks
Interlocking	By keylock
	Mechanical

Complete source-changeover assembly  
 Operating torque (Nm) (typical value for 3-4 poles with front handle)

#### Installation and connection accessories

Bare cable connectors  
 Rear connectors  
 Terminal extensions  
 Spreader  
 One-piece spreader  
 Terminal shrouds  
 Terminal shields  
 Interphase-barrier  
 Front panel escutcheons  
 Coupling accessories  
 Tightening torque for electrical connections (Nm)

#### Dimensions and weights

Overall dimensions H x W x D (mm)	3 poles
	4 poles
Approximate weight (kg)	3 poles
	4 poles

#### Enclosure dimensions for lthe

H x W x D (mm)

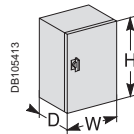



# Switch-disconnector selection

## Interpact INS40 to 160

	INS40	INS63	INS80	INS100	INS125	INS160
■	■	■	■	■	■	■
-	-	-	-	■	■	■
■	■	■	■	-	-	-
■	■	■	■	■	■	■
■	■	■	■	■	■	■
-	-	-	-	-	-	-
-	-	-	-	-	-	-
-	-	-	-	-	-	-
■	■	■	■	■	■	■
-	-	-	-	-	-	-
-	-	-	-	-	-	-
■	■	■	■	■	■	■
-	-	-	-	-	-	-
-	-	-	-	-	-	-
■	■	■	■	■	■	■
-	-	-	-	-	-	-
-	-	-	-	-	-	-
0.7 < Nm < 1.3	0.7 < Nm < 1.3	0.7 < Nm < 1.3	1.4 < Nm < 2	1.4 < Nm < 2	1.4 < Nm < 2	
■	■	■	■	■	■	
-	-	-	-	-	-	
-	-	-	-	-	-	
-	-	-	-	-	-	
-	-	-	-	-	-	
■	■	■	■	■	■	
■	■	■	■	■	■	
-	-	-	-	-	-	
-	-	-	-	-	-	
8	8	8	8	8	8	
85 x 90 x 62.5	85 x 90 x 62.5	85 x 90 x 62.5	100 x 135 x 62.5	100 x 135 x 62.5	100 x 135 x 62.5	
85 x 90 x 62.5	85 x 90 x 62.5	85 x 90 x 62.5	100 x 135 x 62.5	100 x 135 x 62.5	100 x 135 x 62.5	
0.5	0.5	0.5	0.8	0.8	0.8	
0.6	0.6	0.6	0.9	0.9	0.9	
190 x 115 x 55	190 x 115 x 55	190 x 115 x 55	260 x 160 x 55	260 x 160 x 55	260 x 160 x 55	

# Switch-disconnector selection

## Interpact INS250-100 to 630

056648a-41



Interpact INS250 switch-disconnector.

056652a-41



Interpact INS250 emergency-off switch-disconnector.

059487a-54



Interpact INS400 switch-disconnector.

059488a-54



Interpact INS400 emergency-off switch-disconnector.

### Interpact INS switch-disconnectors

Number of poles

#### Electrical characteristics as defined by IEC 60947-1 / 60947-3 and EN 60947-1 / 60947-3

Conventional thermal current (A)	<b>I<sub>th</sub></b>	at 60 °C
Conventional thermal current in enclosure	<b>I<sub>the</sub></b>	at 60 °C
Rated insulation level (V)	<b>Ui</b>	AC 50/60 Hz
Impulse-withstand voltage (kV)	<b>U<sub>imp</sub></b>	
Rated operational voltage (V)	<b>U<sub>e</sub></b>	AC 50/60 Hz DC
Rated operational voltage AC20 and DC20 (V)		AC 50/60 Hz
Rated operational current (A)	<b>I<sub>e</sub></b>	<b>Electrical AC 50/60 Hz</b>

220-240 V  
380-415 V  
440-480 V<sup>(1)</sup>  
500-525 V  
660-690 V

#### Electrical DC

125 V (2P in series)  
250 V (4P in series)

Rated operational power AC23 (kW)

#### Electrical AC 50/60 Hz

220-240 V  
230 V (NEMA)  
380-415 V  
440 V  
480 V (NEMA)  
500-525 V  
660-690 V

Rated duties

Uninterrupted duty  
Intermittent duty

Short-circuit making capacity (kA peak)

**I<sub>cm</sub>**

Min. (switch-disconnector alone)  
Max. (with upstream protection circuit breaker)

Short-time withstand current (A rms)

**I<sub>cw</sub>**

1 s  
3 s  
20 s  
30 s

Suitability for isolation

Durability (O-C cycles)

Mechanical

#### Electrical AC 50/60 Hz

440 V  
500 V  
690 V

#### Electrical DC

250 V

Positive contact indication

Visible break

Emergency-off switch disconnector

Degree of pollution

#### Upstream protection

See the "Additional characteristics" page D-1.

**(1)** Suitable for 480 V NEMA.

**(2)** 550 A (DC).

# Switch-disconnector selection

## Interpact INS250-100 to 630

INS250-100		INS250-160		INS250-200		INS250		INS320		INS400		INS500		INS630	
3-4		3-4		3-4		3-4		3-4		3-4		3-4		3-4	
100		160		200		250		320		400		500		630	
100		160		200		250		320		400		500		630 <sup>(2)</sup>	
750		750		750		750		750		750		750		750	
8		8		8		8		8		8		8		8	
690		690		690		690		690		690		690		690	
250		250		250		250		250		250		250		250	
750		750		750		750		750		750		750		750	
AC22A	AC23A	AC22A	AC23A	AC22A	AC23A	AC22A	AC23A	AC22A	AC23A	AC22A	AC23A	AC22A	AC23A	AC22A	AC23A
100	100	160	160	200	200	250	250	320	320	400	400	500	500	630	630
100	100	160	160	200	200	250	250	320	320	400	400	500	500	630	630
100	100	160	160	200	200	250	250	320	320	400	400	500	500	630	630
100	100	160	160	200	200	250	250	320	320	400	400	500	500	630	630
100	100	160	160	200	200	250	250	320	320	400	400	500	500	630	630
DC22A	DC23A	DC22A	DC23A	DC22A	DC23A	DC22A	DC23A	DC22A	DC23A	DC22A	DC23A	DC22A	DC23A	DC22A	DC23A
100	100	160	160	200	200	250	250	320	320	400	400	500	500	550	550
100	100	160	160	200	200	250	250	320	320	400	400	500	500	550	630
100	100	160	160	200	200	250	250	320	320	400	400	500	500	550	630
22	45	55	75	90	110	132	150	185	220	250	355	400	560	200	200
22	45	55	75	90	110	132	150	185	220	250	355	400	560	200	200
45	75	90	132	150	185	220	250	355	400	560	200	200	200	200	200
55	90	110	150	185	220	250	355	400	560	200	200	200	200	200	200
55	90	110	150	185	220	250	355	400	560	200	200	200	200	200	200
55	110	132	160	210	250	320	400	500	630	800	1000	1250	1600	2000	2500
55	90	110	160	210	250	320	400	500	630	800	1000	1250	1600	2000	2500
■	■	■	■	■	■	■	■	■	■	■	■	■	■	■	■
Class 120 - 60 %		Class 120 - 60 %		Class 120 - 60 %		Class 120 - 60 %		Class 120 - 60 %		Class 120 - 60 %		Class 120 - 60 %		Class 120 - 60 %	
30		30		30		30		50		50		50		50	
330		330		330		330		330		330		330		330	
8500		8500		8500		8500		20000		20000		20000		20000	
4900		4900		4900		4900		11500		11500		11500		11500	
2200		2200		2200		2200		4900		4900		4900		4900	
1800		1800		1800		1800		4000		4000		4000		4000	
■		■		■		■		■		■		■		■	
15000		15000		15000		15000		10000		10000		10000		10000	
AC22A	AC23A	AC22A	AC23A	AC22A	AC23A	AC22A	AC23A	AC22A	AC23A	AC22A	AC23A	AC22A	AC23A	AC22A	AC23A
1500	1500	1500	1500	1500	1500	1500	1500	1500	1500	1500	1500	1500	1500	1500	1500
1500	1500	1500	1500	1500	1500	1500	1500	1500	1500	1500	1500	1500	1500	1500	1500
1500	1500	1500	1500	1500	1500	1500	1500	1500	1500	1500	1500	1500	1500	1500	1500
DC22A	DC23A	DC22A	DC23A	DC22A	DC23A	DC22A	DC23A	DC23A	DC23B	DC23A	DC23B	DC23A	DC23B	DC23A	DC23B
1500	1500	1500	1500	1500	1500	1500	1500	1000	-	1000	-	1000	-	1000	200
■	■	■	■	■	■	■	■	■	■	■	■	■	■	■	■
-	-	-	-	-	-	-	-	-	-	-	-	-	-	-	-
■	■	■	■	■	■	■	■	■	■	■	■	■	■	■	■
3	3	3	3	3	3	3	3	3	3	3	3	3	3	3	3
-	-	-	-	-	-	-	-	-	-	-	-	-	-	-	-

# Switch-disconnector selection

## Interpact INS250-100 to 630

### Interpact INS switch-disconnectors

#### Installation

Fixed, front connection  
 Fixed, rear connection  
 On symmetrical rails  
 On a backplate

#### Connection

By cables	To bare cable connectors
By cables with lugs	Directly to terminals
	To spreaders
	To vertical-connection adapters via cable-lug adapters
Flat-facing bars	Directly to terminals
	To spreaders
Edgewise bars	To vertical-connection adapters

Indication and measurement auxiliaries

Auxiliary contacts

Voltage-presence indicator

Current-transformer module

Ammeter module

Control, locking and interlocking

Control	Direct front rotary handle
	Extended front rotary handle
	Direct lateral rotary handle
	Extended lateral rotary handle

Locking	By keylock
	By padlocks

Interlocking	By keylock
	Mechanical

Complete source-changeover assembly

Operating torque (Nm) (typical value for 3-4 poles with front handle)

#### Installation and connection accessories

Bare cable connectors

Rear connectors

Terminal extensions

Spreaders

One-piece spreader

Terminal shrouds

Terminal shields

Interphase-barrier

Front panel escutcheons

Coupling accessories

Tightening torque for electrical connections (Nm)

#### Dimensions and weights

Overall dimensions H x W x D (mm)	3 poles
	4 poles

Approximate weight (kg)	3 poles
	4 poles

#### Enclosure dimensions for the

H x W x D (mm)

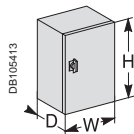



# Switch-disconnector selection

## Interpact INS630b to 2500

PB100076a-55



Interpact INS1600 switch-disconnector.

PB100018a-55



Interpact INS1600 emergency-off switch-disconnector.

PB100020a-65



Interpact INS2500 switch-disconnector.

### Interpact INS switch-disconnectors

Number of poles

#### Electrical characteristics as defined by IEC 60947-1 / 60947-3 and EN 60947-1 / 60947-3

Conventional thermal current (A)	<b>I<sub>th</sub></b>	at 60 °C
Conventional thermal current in enclosure	<b>I<sub>the</sub></b>	at 60 °C
Rated insulation level (V)	<b>U<sub>i</sub></b>	AC 50/60 Hz
Impulse-withstand voltage (kV)	<b>U<sub>imp</sub></b>	
Rated operational voltage (V)	<b>U<sub>e</sub></b>	AC 50/60 Hz DC
Rated operational voltage AC20 and DC20 (V)		AC 50/60 Hz
Rated operational current (A)	<b>I<sub>e</sub></b>	<b>Electrical AC 50/60 Hz</b>

220-240 V

380-415 V

440-480 V <sup>(1)</sup>

500-525 V

660-690 V

#### Electrical DC

125 V (2P in series)

250 V (4P in series)

Rated operational power AC23 (kW)

#### Electrical AC 50/60 Hz

220-240 V

380-400 V

415 V

500-525 V

660-690 V

Rated duties

Uninterrupted duty

Intermittent duty

Short-circuit making capacity (kA peak)

**I<sub>cm</sub>**

Min. (switch-disconnector alone)

Max. (with upstream protection circuit breaker)

Short-time withstand current (kA rms)

**I<sub>cw</sub>**

0.5 s

0.8 s

1 s

3 s

20 s

30 s

Suitability for isolation

Durability (O-C cycles)

Mechanical

#### Electrical AC 50/60 Hz

220-240 V

380-415 V

440-480 V <sup>(1)</sup>

500-525 V

660-690 V

#### Electrical DC

125 V (2P)

250 V (4P)

Positive contact indication

Visible break

Emergency-off switch disconnector

Degree of pollution

#### Upstream protection

See the "Additional characteristics" page D-1.

<sup>(1)</sup> Suitable for 480 V NEMA.

<sup>(2)</sup> For vertical connection busbars only. For horizontal connection busbars, see derating charts in "Installation recommendations" see p. B-22.

# Switch-disconnector selection

## Interpact INS630b to 2500

INS630b			INS800			INS1000			INS1250			INS1600			INS2000			INS2500		
3-4			3-4			3-4			3-4			3-4			3-4			3-4		
630			800			1000			1250			1600 <sup>(2)</sup>			2000			2500		
630			800			1000			1250			1600 <sup>(2)</sup>			2000			2500		
1000			1000			1000			1000			1000			1000			1000		
12			12			12			12			12			12			12		
690			690			690			690			690			690			690		
250			250			250			250			250			250			250		
800			800			800			800			800			800			800		
AC21A	AC22A	AC23A	AC21A	AC22A	AC23A	AC21A	AC22A	AC23A	AC21A	AC22A	AC23A	AC21B	AC22B	AC23A	AC21B	AC22B	AC23B	AC21B	AC22B	AC23B
630	630	630	800	800	800	1000	1000	1000	1250	1250	1250	1600	1600	1250	2000	2000	-	2500	2500	-
630	630	630	800	800	800	1000	1000	1000	1250	1250	1250	1600	1600	1250	2000	2000	-	2500	2500	-
630	630	630	800	800	800	1000	1000	1000	1250	1250	1250	1600	1600	1250	2000	2000	-	2500	2500	-
630	630	630	800	800	800	1000	1000	1000	1250	1250	1250	1600	1600	1250	2000	2000	-	2500	2500	-
630	630	630	800	800	800	1000	1000	1000	1250	1250	1250	1600	1600	1250	2000	2000	-	2500	2500	-
DC21A	DC22A	DC23A	DC21A	DC22A	DC23A	DC21A	DC22A	DC23A	DC21A	DC22A	DC23A	DC21A	DC22A	DC23A	DC21B	DC22B	DC23B	DC21B	DC22B	DC23B
630/2	630/2	630/2	800/2	800/2	800/2	1000/2	1000/2	1000/2	1250/2	1250/2	1250/2	1600/2	1600/2	1600/2	2000/2	2000/2	-	2500/2	2500/2	-
630/4	630/4	630/4	800/4	800/4	800/4	1000/4	1000/4	1000/4	1250/4	1250/4	1250/4	1600/4	1600/4	1600/4	2000/4	2000/4	-	2500/4	2500/4	-
250			250			315			400			400			-			-		
400			400			560			710			710			-			-		
500			500			630			800			800			-			-		
560			560			710			900			900			-			-		
710			710			900			-			-			-			-		
■			■			■			■			■			■			■		
Class 120 - 60 %			Class 120 - 60 %			Class 120 - 60 %			Class 120 - 60 %			Class 120 - 60 %			Class 120 - 60 %			Class 120 - 60 %		
75			75			75			75			75			105			105		
330			330			330			330			330			330			330		
50			50			50			50			50			50			50		
42			42			42			42			42			50			50		
35			35			35			35			35			50			50		
20			20			20			20			20			30			30		
10			10			10			10			10			13			13		
8			8			8			8			8			11			11		
■			■			■			■			■			■			■		
5000			3000			3000			3000			3000			3000			3000		
AC21A	AC22A	AC23A	AC21A	AC22A	AC23A	AC21A	AC22A	AC23A	AC21A	AC22A	AC23A	AC21B	AC22B	AC23A	AC21B	AC22B	AC23B	AC21B	AC22B	AC23B
1000	1000	1000	500	500	500	500	500	500	500	500	500	100	100	500	100	100	-	100	100	-
1000	1000	1000	500	500	500	500	500	500	500	500	500	100	100	500	100	100	-	100	100	-
1000	1000	1000	500	500	500	500	500	500	500	500	500	100	100	500	100	100	-	100	100	-
1000	1000	1000	500	500	500	500	500	500	500	500	500	100	100	500	100	100	-	100	100	-
1000	1000	1000	500	500	500	500	500	500	500	500	500	100	100	500	100	100	-	100	100	-
DC21A	DC22A	DC23A	DC21A	DC22A	DC23A	DC21A	DC22A	DC23A	DC21A	DC22A	DC23A	DC21A	DC22A	DC23B	DC21B	DC22B	DC23B	DC21B	DC22B	DC23B
1000	1000	1000	500	500	500	500	500	500	500	500	500	500	500	500	100	100	-	100	100	-
1000	1000	1000	500	500	500	500	500	500	500	500	500	500	500	500	100	100	-	100	100	-
■			■			■			■			■			■			■		
-			-			-			-			-			-			-		
■			■			■			■			■			■			■		
3			3			3			3			3			3			3		
-			-			-			-			-			-			-		

# Switch-disconnector selection

## Interpact INS630b to 2500

### Interpact INS switch-disconnectors

#### Installation

Fixed, front connection  
 Fixed, rear connection  
 On symmetrical rails  
 On a backplate

#### Connection

By cables	To bare cable connectors
By cables with lugs	Directly to terminals
	To spreaders
	To vertical-connection adapters via cable-lug adapters
Flat-facing bars	Directly to terminals
	To spreaders
Edgewise bars	To vertical-connection adapters

#### Indication and measurement auxiliaries

Auxiliary contacts  
 Voltage-presence indicator  
 Current-transformer module  
 Ammeter module

#### Control, locking and interlocking

Control	Direct front rotary handle
	Extended front rotary handle
	Direct lateral rotary handle
	Extended lateral rotary handle
Locking	By keylock
	By padlocks
Interlocking	By keylock
	Mechanical

Complete source-changeover assembly  
 Operating torque (Nm) (typical value for 3-4 poles with front handle)

#### Installation and connection accessories

Bare cable connectors  
 Rear connectors  
 Terminal extensions  
 Spreader  
 One-piece spreader  
 Terminal shrouds  
 Terminal shields  
 Interphase-barrier  
 Front panel escutcheons  
 Coupling accessories  
 Tightening torque for electrical connections (Nm)

#### Dimensions and weights

Overall dimensions H x W x D (mm)	3 poles
	4 poles
Approximate weight (kg)	3 poles
	4 poles

#### Enclosure dimensions for lthe

H x W x D (mm)

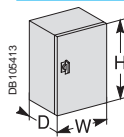



# Switch-disconnector selection

## Interpact INS630b to 2500

	INS630b	INS800	INS1000	INS1250	INS1600	INS2000	INS2500
■	■	■	■	■	■	■	■
■	■	■	■	■	■	■	■
-	-	-	-	-	-	-	-
■	■	■	■	■	■	■	■
-	-	-	-	-	-	-	-
-	-	-	-	-	-	■	■
-	-	-	-	-	-	-	-
■	■	■	■	■	■	-	-
■	■	■	■	■	■	■	■
■	■	■	■	■	■	-	-
■	■	■	■	■	■	-	-
■	■	■	■	■	■	-	-
■	■	■	■	■	■	-	-
-	-	-	-	-	-	-	-
-	-	-	-	-	-	-	-
-	-	-	-	-	-	-	-
■	■	■	■	■	■	■	■
■	■	■	■	■	■	■	■
-	-	-	-	-	-	-	-
-	-	-	-	-	-	-	-
-	-	-	-	-	-	-	-
30	30	30	30	30	30	60	60
-	-	-	-	-	-	-	-
-	-	-	-	-	-	-	-
■	■	■	■	■	■	■	■
■	■	■	■	■	■	■	■
-	-	-	-	-	-	-	-
-	-	-	-	-	-	-	-
■	■	■	■	■	■	■	■
■	■	■	■	■	■	■	■
■	■	■	■	■	■	■	■
-	-	-	-	-	-	-	-
50	50	50	50	50	50	50	50
300 x 340 x 146.5	300 x 340 x 146.5	300 x 340 x 146.5	300 x 340 x 146.5	300 x 340 x 146.5	300 x 340 x 146.5	440 x 347.5 x 227.5	440 x 347.5 x 227.5
300 x 410 x 146.5	300 x 410 x 146.5	300 x 410 x 146.5	300 x 410 x 146.5	300 x 410 x 146.5	300 x 410 x 146.5	440 x 462.5 x 227.5	440 x 462.5 x 227.5
14	14	14	14	14	14	35	35
18	18	18	18	18	18	45	45
-	-	-	-	-	-	-	-

# Switch-disconnector selection

## Interpact INV100 to 630

056650a-41



Interpact INV250 switch-disconnector.

056654a-41



Interpact INV250 emergency-off switch-disconnector.

058491a-54

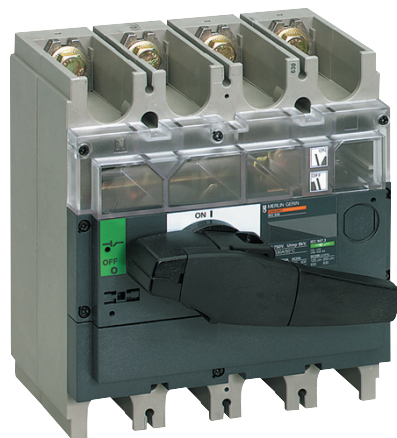

Interpact INV400 Std.

058493a-52



Interpact INV400 emergency-off switch-disconnector.

### Interpact INV switch-disconnectors

Number of poles

#### Electrical characteristics as defined by IEC 60947-1 / 60947-3 and EN 60947-1 / 60947-3

Conventional thermal current (A)	<b>I<sub>th</sub></b>	at 60 °C
Conventional thermal current in enclosure	<b>I<sub>the</sub></b>	at 60 °C
Rated insulation level (V)	<b>U<sub>i</sub></b>	AC 50/60 Hz
Impulse-withstand voltage (kV)	<b>U<sub>imp</sub></b>	
Rated operational voltage (V)	<b>U<sub>e</sub></b>	AC 50/60 Hz DC
Rated operational voltage AC20 and DC20 (V)		AC 50/60 Hz
Rated operational current (A)	<b>I<sub>e</sub></b>	<b>Electrical AC 50/60 Hz</b>

220-240 V  
380-415 V  
440-480 V <sup>(1)</sup>  
500-525 V  
660-690 V

#### Electrical DC

125 V (2P in series)  
250 V (4P in series)

Rated operational power AC23 (kW)	<b>Electrical AC 50/60 Hz</b>
	220-240 V 230 V (NEMA) 380-415 V 440 V 480 V (NEMA) 500-525 V 660-690 V

Rated duties	Uninterrupted duty Intermittent duty
Short-circuit making capacity (kA peak)	<b>I<sub>cm</sub></b> Min. (switch-disconnector alone) Max. (with upstream protection circuit breaker)
Short-time withstand current (A rms)	<b>I<sub>cw</sub></b> 1 s 3 s 20 s 30 s

Suitability for isolation	Mechanical
Durability (O-C cycles)	<b>Electrical AC 50/60 Hz</b> 440 V 500 V 690 V
	<b>Electrical DC</b> 250 V

Positive contact indication  
Visible break  
Emergency-off switch disconnector  
Degree of pollution

#### Upstream protection

See the "Additional characteristics" page D-1.

<sup>(1)</sup> Suitable for 480 V NEMA.

<sup>(2)</sup> 550 A (DC).

# Switch-disconnector selection

## Interpact INV100 to 630

INV100			INV160			INV200			INV250			INV320			INV400			INV500			INV630					
3-4			3-4			3-4			3-4			3-4			3-4			3-4			3-4					
100			160			200			250			320			400			500			630					
100			160			200			250			320			400			500			630 <sup>(2)</sup>					
750			750			750			750			750			750			750			750					
8			8			8			8			8			8			8			8					
690			690			690			690			690			690			690			690					
250			250			250			250			250			250			250			250					
750			750			750			750			750			750			750			750					
AC21A	AC22A	AC23A	AC21A	AC22A	AC23A	AC21A	AC22A	AC23A	AC21A	AC22A	AC23A	AC21A	AC22A	AC23A	AC21A	AC22A	AC23A	AC21A	AC22A	AC23A	AC21A	AC22A	AC23A	AC21A	AC22A	AC23A/AC23B
100	100	100	160	160	160	200	200	200	250	250	250	320	320	320	400	400	400	500	500	500	630	630	630	630	630	630/630
100	100	100	160	160	160	200	200	200	250	250	250	320	320	320	400	400	400	500	500	500	630	630	630	630	630	630/630
100	100	100	160	160	160	200	200	200	250	250	200	320	320	320	400	400	400	500	500	500	630	630	630	630	630	500/630
100	100	100	160	160	160	200	200	200	250	250	200	320	320	320	400	400	400	500	500	500	630	630	630	630	550	500/630
DC21A	DC22A	DC23B	DC21A	DC22A	DC23B	DC21A	DC22A	DC23B	DC21A	DC22A	DC23B	DC21A	DC22A	DC23A	DC21A	DC22A	DC23A	DC21A	DC22A	DC23A	DC21A	DC22A	DC23A	DC21A	DC22A	DC23A/DC23B
100	100	100	160	160	160	200	200	200	250	250	200	320	320	320	400	400	400	500	500	500	550	550	550	550	550	550/630
100	100	100	160	160	160	200	200	200	250	250	200	320	320	320	400	400	400	500	500	500	550	550	550	550	550	550/630
22			45			55			75			90			110			132			200					
22			45			55			75			90			110			150			200					
45			75			90			132			160			200			250			315					
55			90			110			150			185			220			250			400					
55			50			110			150			185			220			250			375					
55			110			132			132			220			250			355			400					
55			90			160			160			250			400			500			560					
■			■			■			■			■			■			■			■			■		
Class 120 - 60 %			Class 120 - 60 %			Class 120 - 60 %			Class 120 - 60 %			Class 120 - 60 %			Class 120 - 60 %			Class 120 - 60 %			Class 120 - 60 %			Class 120 - 60 %		
30			30			30			30			50			50			50			50			50		
330			330			330			330			330			330			330			330			330		
8500			8500			8500			8500			20000			20000			20000			20000			20000		
4900			4900			4900			4900			11500			11500			11500			11500			11500		
2200			2200			2200			2200			4900			4900			4900			4900			4900		
1800			1800			1800			1800			4000			4000			4000			4000			4000		
■			■			■			■			■			■			■			■			■		
15000			15000			15000			15000			10000			10000			10000			10000			10000		
AC22A	AC23A	AC22A	AC23A	AC22A	AC23A	AC22A	AC23A	AC22A	AC23A	AC21A	AC22A	AC23A	AC21A	AC22A	AC23A	AC21A	AC22A	AC23A	AC21A	AC22A	AC23A	AC21A	AC22A	AC23A/AC23B		
1500	1500	1500	1500	1500	1500	1500	1500	1500	1500	1000	1000	1000	1000	1000	1000	1000	1000	1000	1000	1000	1000	1000	1000	1000		
1500	1500	1500	1500	1500	1500	1500	1500	1500	1500	1000	1000	1000	1000	1000	1000	1000	1000	1000	1000	1000	1000	1000	1000	1000		
1500	1500	1500	1500	1500	1500	1500	1500	1500	1500	1000	1000	1000	1000	1000	1000	1000	1000	1000	1000	1000	1000	1000	1000	1000/200		
DC22A	DC23A	DC22A	DC23A	DC22A	DC23A	DC22A	DC23A	DC22A	DC23A	DC21A	DC22A	DC23A	DC21A	DC22A	DC23A	DC21A	DC22A	DC23A	DC21A	DC22A	DC23A	DC21A	DC22A	DC23A/DC23B		
1500	1500	1500	1500	1500	1500	1500	1500	1500	1500	1000	1000	1000	1000	1000	1000	1000	1000	1000	1000	1000	1000	1000	1000	1000/200		
■			■			■			■			■			■			■			■			■		
■			■			■			■			■			■			■			■			■		
■			■			■			■			■			■			■			■			■		
3			3			3			3			3			3			3			3			3		
-			-			-			-			-			-			-			-			-		

# Switch-disconnector selection

## Interpact INV100 to 630

### Interpact INV switch-disconnectors

#### Installation

Fixed, front connection  
 Fixed, rear connection  
 On symmetrical rails  
 On a backplate

#### Connection

By cables	To bare cable connectors
By cables with lugs	Directly to terminals
	To spreaders
	To vertical-connection adapters via cable-lug adapters
Flat-facing bars	Directly to terminals
	To spreaders
Edgewise bars	To vertical-connection adapters

#### Indication and measurement auxiliaries

Auxiliary contacts  
 Voltage-presence indicator  
 Current-transformer module  
 Ammeter module

#### Control, locking and interlocking

Control	Direct front rotary handle
	Extended front rotary handle
	Direct lateral rotary handle
	Extended lateral rotary handle
Locking	By keylock
	By padlocks
Interlocking	By keylock
	Mechanical

Complete source-changeover assembly  
 Operating torque (Nm) (typical value for 3-4 poles with front handle)

#### Installation and connection accessories

Bare cable connectors  
 Rear connectors  
 Terminal extensions  
 Spreader  
 One-piece spreader  
 Terminal shrouds  
 Terminal shields  
 Interphase-barrier  
 Front panel escutcheons  
 Coupling accessories  
 Tightening torque for electrical connections (Nm)

#### Dimensions and weights

Overall dimensions H x W x D (mm)	3 poles
	4 poles
Approximate weight (kg)	3 poles
	4 poles

#### Enclosure dimensions for lthe

H x W x D (mm)

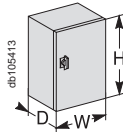

# Switch-disconnector selection

## Interpact INV100 to 630

	INV100	INV160	INV200	INV250	INV320	INV400	INV500	INV630
■	■	■	■	■	■	■	■	■
■	■	■	■	■	■	■	■	■
-	-	-	-	-	-	-	-	-
■	■	■	■	■	■	■	■	■
■	■	■	■	■	■	■	■	■
■	■	■	■	■	■	■	■	■
-	-	-	-	-	-	-	-	-
■	■	■	■	■	■	■	■	■
■	■	■	■	■	■	■	■	■
-	-	-	-	-	■	■	■	■
■	■	■	■	■	■	■	■	■
■	■	■	■	■	■	■	■	■
■	■	■	■	■	■	■	■	■
■	■	■	■	■	■	■	■	■
-	-	-	-	-	-	-	-	-
5 < Nm < 6.2	5 < Nm < 6.2	5 < Nm < 6.2	5 < Nm < 6.2	5 < Nm < 6.2	13.5 < Nm < 16.5	13.5 < Nm < 16.5	13.5 < Nm < 16.5	13.5 < Nm < 16.5
■	■	■	■	■	■	■	■	■
■	■	■	■	■	■	■	■	■
■	■	■	■	■	■	■	■	■
■	■	■	■	■	■	■	■	■
-	-	-	-	-	-	-	-	-
■	■	■	■	■	■	■	■	■
■	■	■	■	■	■	■	■	■
■	■	■	■	■	■	■	■	■
15	15	15	15	50	50	50	50	50
136 x 140 x 96	136 x 140 x 96	136 x 140 x 96	136 x 140 x 96	205 x 185 x 130	205 x 185 x 130	205 x 185 x 130	205 x 185 x 130	205 x 185 x 130
136 x 140 x 96	136 x 140 x 96	136 x 140 x 96	136 x 140 x 96	205 x 185 x 130	205 x 185 x 130	205 x 185 x 130	205 x 185 x 130	205 x 185 x 130
2	2	2	2	4.6	4.6	4.6	4.6	4.6
2.2	2.2	2.2	2.2	4.9	4.9	4.9	4.9	4.9
400 x 300 x 200	400 x 300 x 200	400 x 300 x 200	400 x 300 x 200	600 x 400 x 200	600 x 400 x 200	600 x 400 x 200	600 x 400 x 200	600 x 400 x 200

# Switch-disconnector selection

## Interpact INV630b to 2500

PB100077a-55



Interpact INV1600 switch-disconnector.

PB100019a-55

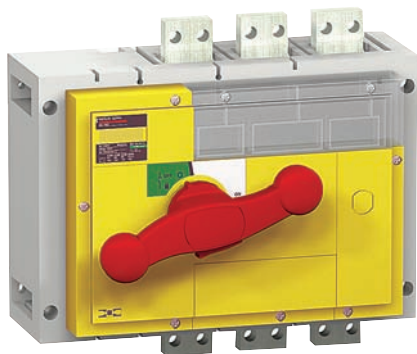

Interpact INV1600 emergency-off switch-disconnector.

PB100021a-65

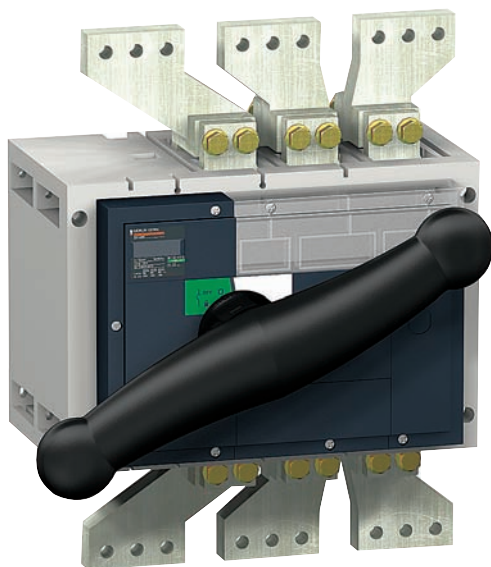

Interpact INV2500 switch-disconnector.

### Interpact INV switch-disconnectors

Number of poles

#### Electrical characteristics as defined by IEC 60947-1 / 60947-3 and EN 60947-1 / 60947-3

Conventional thermal current (A)	<b>I<sub>th</sub></b>	at 60 °C
Conventional thermal current in enclosure	<b>I<sub>the</sub></b>	at 60 °C
Rated insulation level (V)	<b>U<sub>i</sub></b>	AC 50/60 Hz
Impulse-withstand voltage (kV)	<b>U<sub>imp</sub></b>	
Rated operational voltage (V)	<b>U<sub>e</sub></b>	AC 50/60 Hz DC
Rated operational voltage AC20 and DC20 (V)		AC 50/60 Hz
Rated operational current (A)	<b>I<sub>e</sub></b>	<b>Electrical AC 50/60 Hz</b>

220-240 V

380-415 V

440-480 V <sup>(1)</sup>

500-525 V

660-690 V

#### Electrical DC

125 V (2P in series)

250 V (4P in series)

Rated operational power AC23 (kW)

#### Electrical AC 50/60 Hz

220-240 V

380-400 V

415 V

500-525 V

660-690 V

Rated duties

Uninterrupted duty

Intermittent duty

Short-circuit making capacity (kA peak)

**I<sub>cm</sub>**

Min. (switch-disconnector alone)

Max. (with upstream protection circuit breaker)

Short-time withstand current (kA rms)

**I<sub>cw</sub>**

0.5 s

0.8 s

1 s

3 s

20 s

30 s

Suitability for isolation

Durability (O-C cycles)

Mechanical

#### Electrical AC 50/60 Hz

220-240 V

380-415 V

440-480 V <sup>(1)</sup>

500-525 V

660-690 V

#### Electrical DC

125 V (2P)

250 V (4P)

Positive contact indication

Visible break

Emergency-off switch disconnector

Degree of pollution

#### Upstream protection

See the "Additional characteristics" page D-1.

<sup>(1)</sup> Suitable for 480 V NEMA.

<sup>(2)</sup> For vertical connection busbars only. For horizontal connection busbars, see derating charts in "Installation recommendations" p. B-22.

# Switch-disconnector selection

## Interpact INV630b to 2500

INV630b			INV800			INV1000			INV1250			INV1600			INV2000			INV2500		
3-4			3-4			3-4			3-4			3-4			3-4			3-4		
630			800			1000			1250			1600 <sup>(2)</sup>			2000			2500		
630			800			1000			1250			1600 <sup>(2)</sup>			2000			2500		
1000			1000			1000			1000			1000			1000			1000		
12			12			12			12			12			12			12		
690			690			690			690			690			690			690		
250			250			250			250			250			250			250		
800			800			800			800			800			800			800		
AC21A	AC22A	AC23A	AC21A	AC22A	AC23A	AC21A	AC22A	AC23A	AC21A	AC22A	AC23A	AC21B	AC22B	AC23A	AC21B	AC22B	AC23B	AC21B	AC22B	AC23B
630	630	630	800	800	800	1000	1000	1000	1250	1250	1250	1600	1600	1250	2000	2000	-	2500	2500	-
630	630	630	800	800	800	1000	1000	1000	1250	1250	1250	1600	1600	1250	2000	2000	-	2500	2500	-
630	630	630	800	800	800	1000	1000	1000	1250	1250	1250	1600	1600	1250	2000	2000	-	2500	2500	-
630	630	630	800	800	800	1000	1000	1000	1250	1250	1250	1600	1600	1250	2000	2000	-	2500	2500	-
630	630	630	800	800	800	1000	1000	1000	1250	1250	1250	1600	1600	1250	2000	2000	-	2500	2500	-
630	630	630	800	800	800	1000	1000	1000	1250	1250	1250	1600	1600	1250	2000	2000	-	2500	2500	-
DC21A	DC22A	DC23A	DC21A	DC22A	DC23A	DC21A	DC22A	DC23A	DC21A	DC22A	DC23A	DC21A	DC22A	DC23A	DC21B	DC22B	DC23B	DC21B	DC22B	DC23B
630/2	630/2	630/2	800/2	800/2	800/2	1000/2	1000/2	1000/2	1250/2	1250/2	1250/2	1600/2	1600/2	1600/2	2000/2	2000/2	-	2500/2	2500/2	-
630/4	630/4	630/4	800/4	800/4	800/4	1000/4	1000/4	1000/4	1250/4	1250/4	1250/4	1600/4	1600/4	1600/4	2000/4	2000/4	-	2500/4	2500/4	-
250			250			315			400			400			-			-		
400			400			560			710			710			-			-		
500			500			630			800			800			-			-		
560			560			710			900			900			-			-		
710			710			900			-			-			-			-		
■			■			■			■			■			■			■		
Class 120 - 60 %			Class 120 - 60 %			Class 120 - 60 %			Class 120 - 60 %			Class 120 - 60 %			Class 120 - 60 %			Class 120 - 60 %		
75			75			75			75			75			105			105		
330			330			330			330			330			330			330		
50			50			50			50			50			50			50		
42			42			42			42			42			50			50		
35			35			35			35			35			50			50		
20			20			20			20			20			30			30		
10			10			10			10			10			13			13		
8			8			8			8			8			11			11		
■			■			■			■			■			■			■		
5000			3000			3000			3000			3000			3000			3000		
AC21A	AC22A	AC23A	AC21A	AC22A	AC23A	AC21A	AC22A	AC23A	AC21A	AC22A	AC23A	AC21B	AC22B	AC23A	AC21B	AC22B	AC23B	AC21B	AC22B	AC23B
1000	1000	1000	500	500	500	500	500	500	500	500	500	100	100	500	100	100	-	100	100	-
1000	1000	1000	500	500	500	500	500	500	500	500	500	100	100	500	100	100	-	100	100	-
1000	1000	1000	500	500	500	500	500	500	500	500	500	100	100	500	100	100	-	100	100	-
1000	1000	1000	500	500	500	500	500	500	500	500	500	100	100	500	100	100	-	100	100	-
1000	1000	1000	500	500	500	500	500	500	500	500	500	100	100	500	100	100	-	100	100	-
DC21A	DC22A	DC23A	DC21A	DC22A	DC23A	DC21A	DC22A	DC23A	DC21A	DC22A	DC23A	DC21A	DC22A	DC23B	DC21B	DC22B	DC23B	DC21B	DC22B	DC23B
1000	1000	1000	500	500	500	500	500	500	500	500	500	500	500	500	100	100	-	100	100	-
1000	1000	1000	500	500	500	500	500	500	500	500	500	500	500	500	100	100	-	100	100	-
■			■			■			■			■			■			■		
■			■			■			■			■			■			■		
■			■			■			■			■			-			-		
3			3			3			3			3			3			3		
-			-			-			-			-			-			-		

# Switch-disconnector selection

## Interpact INV630b to 2500

### Interpact INV switch-disconnectors

#### Installation

Fixed, front connection  
 Fixed, rear connection  
 On symmetrical rails  
 On a backplate

#### Connection

By cables	To bare cable connectors
By cables with lugs	Directly to terminals
	To spreaders
	To vertical-connection adapters via cable-lug adapters
Flat-facing bars	Directly to terminals
	To spreaders
Edgewise bars	To vertical-connection adapters

#### Indication and measurement auxiliaries

Auxiliary contacts  
 Voltage-presence indicator  
 Current-transformer module  
 Ammeter module

#### Control, locking and interlocking

Control	Direct front rotary handle
	Extended front rotary handle
	Direct lateral rotary handle
	Extended lateral rotary handle
Locking	By keylock
	By padlocks
Interlocking	By keylock
	Mechanical

Complete source-changeover assembly  
 Operating torque (Nm) (typical value for 3-4 poles with front handle)

#### Installation and connection accessories

Bare cable connectors  
 Rear connectors  
 Terminal extensions  
 Spreader  
 One-piece spreader  
 Terminal shrouds  
 Terminal shields  
 Interphase-barrier  
 Front panel escutcheons  
 Coupling accessories  
 Tightening torque for electrical connections (Nm)

#### Dimensions and weights

Overall dimensions H x W x D (mm)	3 poles
	4 poles
Approximate weight (kg)	3 poles
	4 poles

#### Enclosure dimensions for lthe

H x W x D (mm)

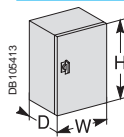



# Switch-disconnector selection

## Interpact INV630b to 2500

	INV630b	INV800	INV1000	INV1250	INV1600	INV2000	INV2500
■	■	■	■	■	■	■	■
■	■	■	■	■	■	■	■
-	-	-	-	-	-	-	-
■	■	■	■	■	■	■	■
-	-	-	-	-	-	-	-
-	-	-	-	-	-	■	■
-	-	-	-	-	-	-	-
■	■	■	■	■	■	-	-
■	■	■	■	■	■	■	■
■	■	■	■	■	■	-	-
■	■	■	■	■	■	-	-
■	■	■	■	■	■	-	-
-	-	-	-	-	-	-	-
-	-	-	-	-	-	-	-
-	-	-	-	-	-	-	-
■	■	■	■	■	■	■	■
■	■	■	■	■	■	■	■
-	-	-	-	-	-	-	-
-	-	-	-	-	-	-	-
-	-	-	-	-	-	-	-
30	30	30	30	30	30	60	60
-	-	-	-	-	-	-	-
-	-	-	-	-	-	-	-
■	■	■	■	■	■	■	■
■	■	■	■	■	■	■	■
-	-	-	-	-	-	-	-
-	-	-	-	-	-	-	-
■	■	■	■	■	■	■	■
■	■	■	■	■	■	■	■
■	■	■	■	■	■	■	■
-	-	-	-	-	-	-	-
50	50	50	50	50	50	50	50
300 x 340 x 146.5	300 x 340 x 146.5	300 x 340 x 146.5	300 x 340 x 146.5	300 x 340 x 146.5	300 x 340 x 146.5	440 x 347.5 x 227.5	440 x 347.5 x 227.5
300 x 410 x 146.5	300 x 410 x 146.5	300 x 410 x 146.5	300 x 410 x 146.5	300 x 410 x 146.5	300 x 410 x 146.5	440 x 462.5 x 227.5	440 x 462.5 x 227.5
14	14	14	14	14	14	35	35
18	18	18	18	18	18	45	45
-	-	-	-	-	-	-	-

# Complete source-changeover assembly selection

## Interpact INS250-100 to 630

056648a-41



Complete source-changeover assembly.

### Interpact INS switch-disconnectors

Number of poles

#### Electrical characteristics as defined by IEC 60947-1 / 60947-3 and EN 60947-1 / 60947-3

Conventional thermal current (A)	<b>I<sub>th</sub></b>	at 60 °C
Conventional thermal current in enclosure	<b>I<sub>the</sub></b>	at 60 °C
Rated insulation level (V)	<b>U<sub>i</sub></b>	AC 50/60 Hz
Impulse-withstand voltage (kV)	<b>U<sub>imp</sub></b>	
Rated operational voltage (V)	<b>U<sub>e</sub></b>	AC 50/60 Hz DC
Rated operational voltage AC20 and DC20 (V)		AC 50/60 Hz
Rated operational current (A)	<b>I<sub>e</sub></b>	<b>Electrical AC 50/60 Hz</b> 220-240 V 380-415 V 440-480 V <sup>(1)</sup> 500-525 V 660-690 V
		<b>Electrical DC</b> 125 V (2P in series) 250 V (4P in series)
Rated duties		Uninterrupted duty Intermittent duty
Short-circuit making capacity (kA peak)	<b>I<sub>cm</sub></b>	Min. (switch-disconnector alone) Max. (with upstream protection circuit breaker)
Short-time withstand current (A rms)	<b>I<sub>cw</sub></b>	1 s 3 s 20 s 30 s
Suitability for isolation		
Durability (category A) (O - C-O cycles)		<b>Mechanical</b> <b>Electrical AC 50/60 Hz</b> 440 V 500 V 690 V <b>Electrical DC</b> 250 V
Positive contact indication		
Visible break		
Emergency-off switch disconnector		
Degree of pollution		

#### Upstream protection

See the "Additional characteristics" [page D-1](#).

<sup>(1)</sup> Suitable for 480 V NEMA.

# Complete source-changeover assembly selection

## Interpact INS250-100 to 630

INS250-100		INS250-160		INS250-200		INS250		INS320		INS400		INS500		INS630	
3-4		3-4		3-4		3-4		3-4		3-4		3-4		3-4	
100		160		200		250		320		400		500		630	
100		160		200		250		320		400		500		630	
750		750		750		750		750		750		750		750	
8		8		8		8		8		8		8		8	
690		690		690		690		690		690		690		690	
250		250		250		250		250		250		250		250	
750		750		750		750		750		750		750		750	
AC22A	AC23A	AC22A	AC23A	AC22A	AC23A	AC22A	AC23A	AC22A	AC23A	AC22A	AC23A	AC22A	AC23A	AC22A	AC23A
100	100	160	160	200	200	250	250	320	320	400	400	500	500	630	630
100	100	160	160	200	200	250	250	320	320	400	400	500	500	630	630
100	100	160	160	200	200	250	250	320	320	400	400	500	500	630	630
100	100	160	160	200	200	250	250	320	320	400	400	500	500	630	630
100	100	160	160	200	200	250	250	320	320	400	400	500	500	630	630
DC22A	DC23A	DC22A	DC23A	DC22A	DC23A	DC22A	DC23A	DC22A	DC23A	DC22A	DC23A	DC22A	DC23A	DC22A	DC23A
100	100	160	160	200	200	250	250	320	320	400	400	500	500	550	550
100	100	160	160	200	200	250	250	320	320	400	400	500	500	550	550
■	■	■	■	■	■	■	■	■	■	■	■	■	■	■	■
Class 120 - 60 %		Class 120 - 60 %		Class 120 - 60 %		Class 120 - 60 %		Class 120 - 60 %		Class 120 - 60 %		Class 120 - 60 %		Class 120 - 60 %	
30		30		30		30		50		50		50		50	
330		330		330		330		330		330		330		330	
8500		8500		8500		8500		20000		20000		20000		20000	
4900		4900		4900		4900		11500		11500		11500		11500	
2200		2200		2200		2200		4900		4900		4900		4900	
1800		1800		1800		1800		4000		4000		4000		4000	
■	■	■	■	■	■	■	■	■	■	■	■	■	■	■	■
15000		15000		15000		15000		10000		10000		10000		10000	
AC22A	AC23A	AC22A	AC23A	AC22A	AC23A	AC22A	AC23A	AC22A	AC23A	AC22A	AC23A	AC22A	AC23A	AC22A	AC23A
1500	1500	1500	1500	1500	1500	1500	1500	1500	1500	1500	1500	1500	1500	1500	1500
1500	1500	1500	1500	1500	1500	1500	1500	1500	1500	1500	1500	1500	1500	1500	1500
1500	1500	1500	1500	1500	1500	1500	1500	1500	1500	1500	1500	1500	1500	1500	1500
DC22A	DC23A	DC22A	DC23A	DC22A	DC23A	DC22A	DC23A	DC23A	DC23B	DC23A	DC23B	DC23A	DC23B	DC23A	DC23B
1500	1500	1500	1500	1500	1500	1500	1500	1000	-	1000	-	1000	-	1000	200
■	■	■	■	■	■	■	■	■	■	■	■	■	■	■	■
-	-	-	-	-	-	-	-	-	-	-	-	-	-	-	-
-	-	-	-	-	-	-	-	-	-	-	-	-	-	-	-
3	3	3	3	3	3	3	3	3	3	3	3	3	3	3	3
-	-	-	-	-	-	-	-	-	-	-	-	-	-	-	-

# Complete source-changeover assembly selection

## Interpact INS250-100 to 630

### Interpact INS switch-disconnectors

#### Installation

Fixed, front connection  
 Fixed, rear connection  
 On symmetrical rails  
 On a backplate

#### Connection

By cables	To bare cable connectors
By cables with lugs	Directly to terminals
	To spreaders
	To vertical-connection adapters via cable-lug adapters
Flat-facing bars	Directly to terminals
	To spreaders
Edgewise bars	To vertical-connection adapters

#### Indication and measurement auxiliaries

Auxiliary contacts  
 Voltage-presence indicator  
 Current-transformer module  
 Ammeter module

#### Control, locking and interlocking

Control	Direct front rotary handle
	Extended front rotary handle
	Direct lateral rotary handle
	Extended lateral rotary handle
Interlocking	By keylock
	Mechanical

Complete source-changeover assembly

Operating torque (Nm) (typical value for 3-4 poles with front handle)

#### Installation and connection accessories

Bare cable connectors  
 Rear connectors  
 Terminal extensions  
 Spreaders  
 One-piece spreader  
 Terminal shrouds  
 Terminal shields  
 Interphase-barrier  
 Front panel escutcheons  
 Coupling accessories  
 Tightening torque for electrical connections (Nm)

#### Dimensions and weights

Overall dimensions H x W x D (mm)	3 poles
	4 poles
Approximate weight (kg)	3 poles
	4 poles

# Complete source-changeover assembly selection

Interpact INS250-100 to 630

	INS250-100	INS250-160	INS250-200	INS250	INS320	INS400	INS500	INS630
■	■	■	■	■	■	■	■	■
■	■	■	■	■	■	■	■	■
-	-	-	-	-	-	-	-	-
■	■	■	■	■	■	■	■	■
■	■	■	■	■	■	■	■	■
■	■	■	■	■	■	■	■	■
-	-	-	-	-	-	-	-	-
■	■	■	■	■	■	■	■	■
■	■	■	■	■	■	■	■	■
-	-	-	-	-	-	-	-	-
■	■	■	■	■	■	■	■	■
■	■	■	■	■	■	■	■	■
■	■	■	■	■	■	■	■	■
5 < Nm < 6.2	5 < Nm < 6.2	5 < Nm < 6.2	5 < Nm < 6.2	13.5 < Nm < 16.5	13.5 < Nm < 16.5	13.5 < Nm < 16.5	13.5 < Nm < 16.5	13.5 < Nm < 16.5
■	■	■	■	■	■	■	■	■
■	■	■	■	■	■	■	■	■
■	■	■	■	■	■	■	■	■
-	-	-	-	-	-	-	-	-
-	-	-	-	-	-	-	-	-
-	-	-	-	-	-	-	-	-
■	■	■	■	■	■	■	■	■
■	■	■	■	■	■	■	■	■
-	-	-	-	-	-	-	-	-
■	■	■	■	■	■	■	■	■
15	15	15	15	50	50	50	50	50
136 x 295 x 131	136 x 295 x 131	136 x 295 x 131	136 x 295 x 131	205 x 395 x 155	205 x 395 x 155	205 x 395 x 155	205 x 395 x 155	205 x 395 x 155
136 x 295 x 131	136 x 295 x 131	136 x 295 x 131	136 x 295 x 131	205 x 395 x 155	205 x 395 x 155	205 x 395 x 155	205 x 395 x 155	205 x 395 x 155
6.4	6.4	6.4	6.4	13.5	13.5	13.5	13.5	13.5
6.4	6.4	6.4	6.4	13.5	13.5	13.5	13.5	13.5

# Switch-disconnector selection

## Interpact INS40 to 80

DB117753

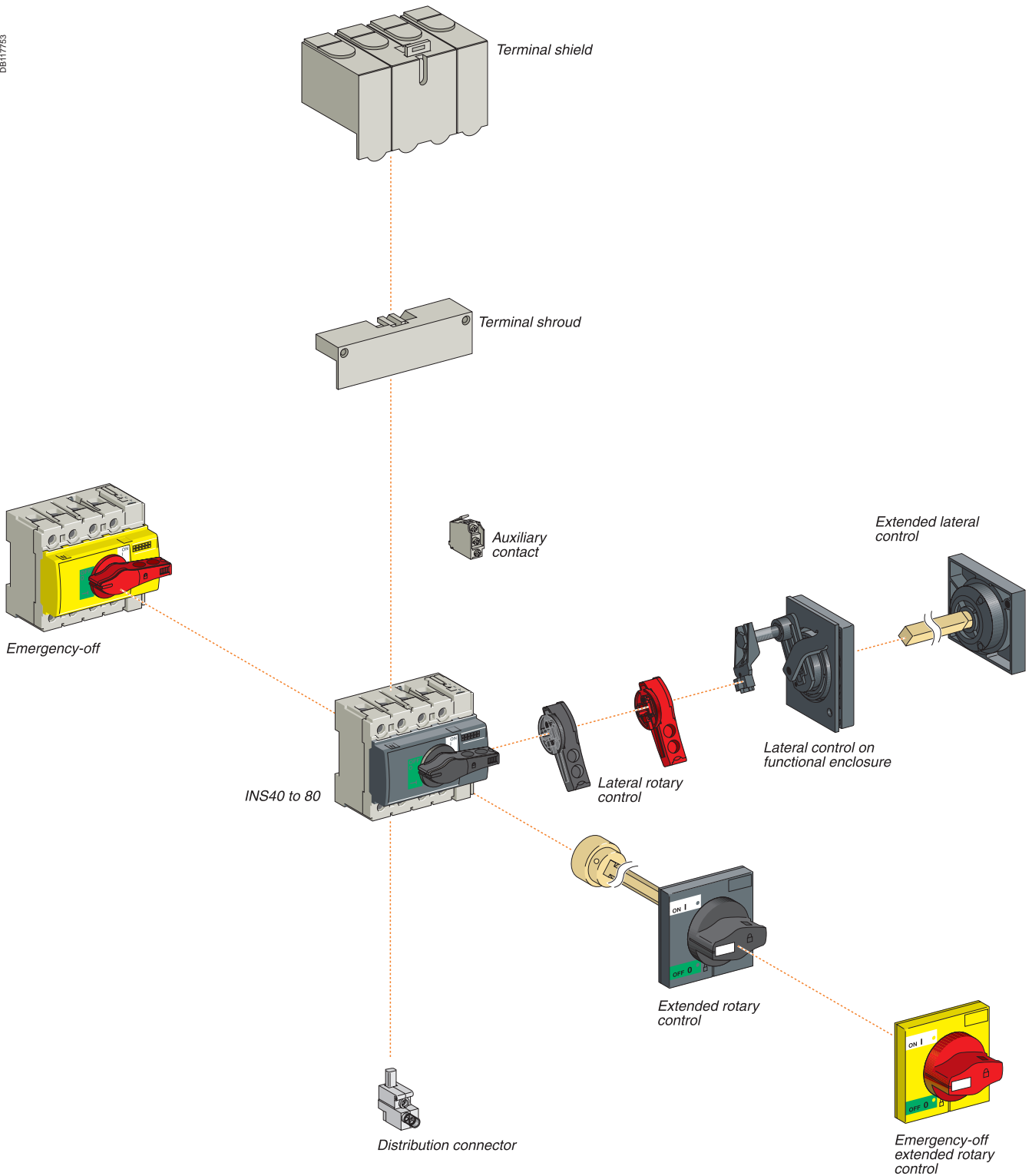

# Switch-disconnector selection

## Interpact INS100 to 160

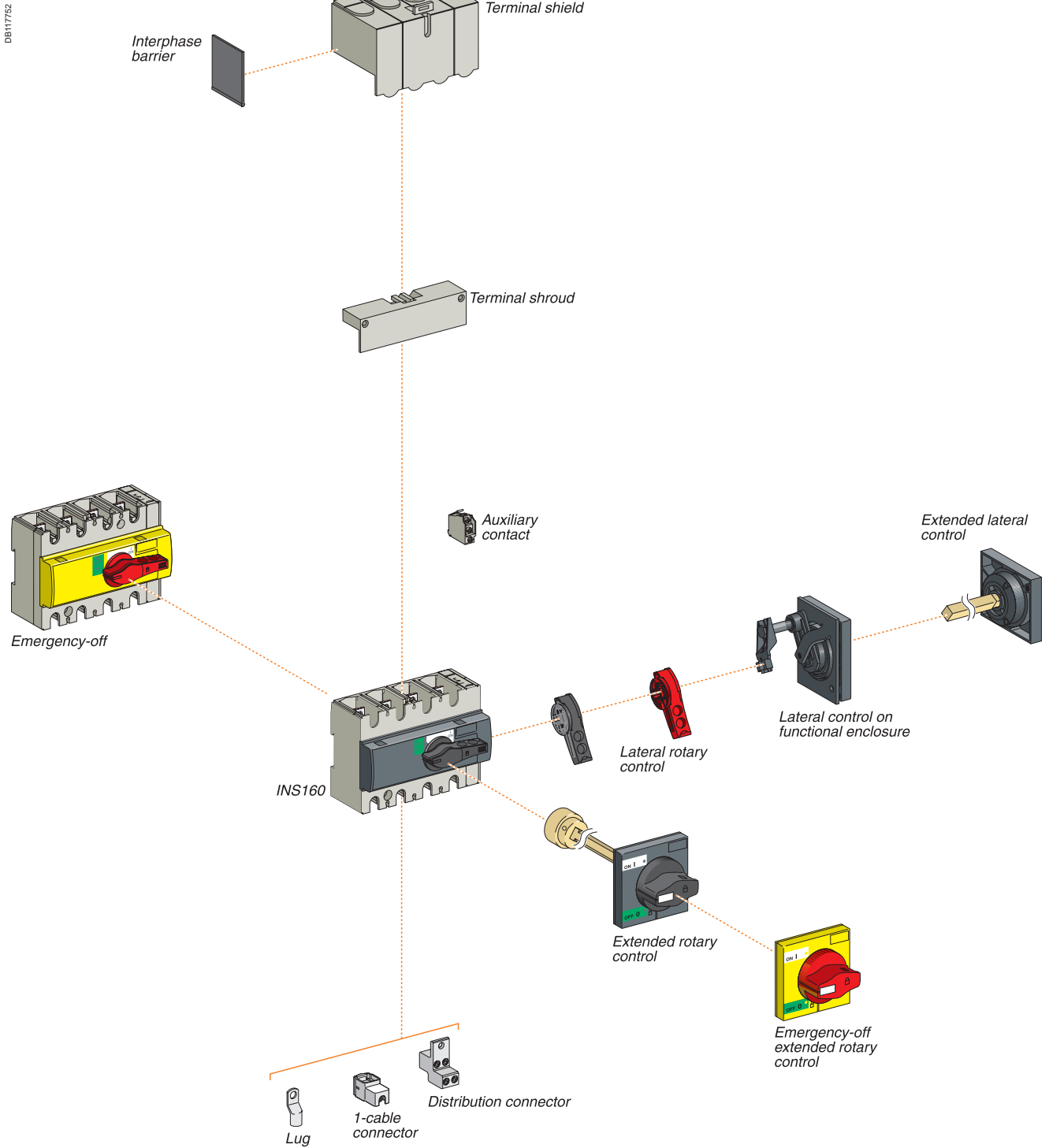

DB117752

# Switch-disconnector selection

Interpact INS250-100 to 630

Interpact INV100 to 630

DB117755

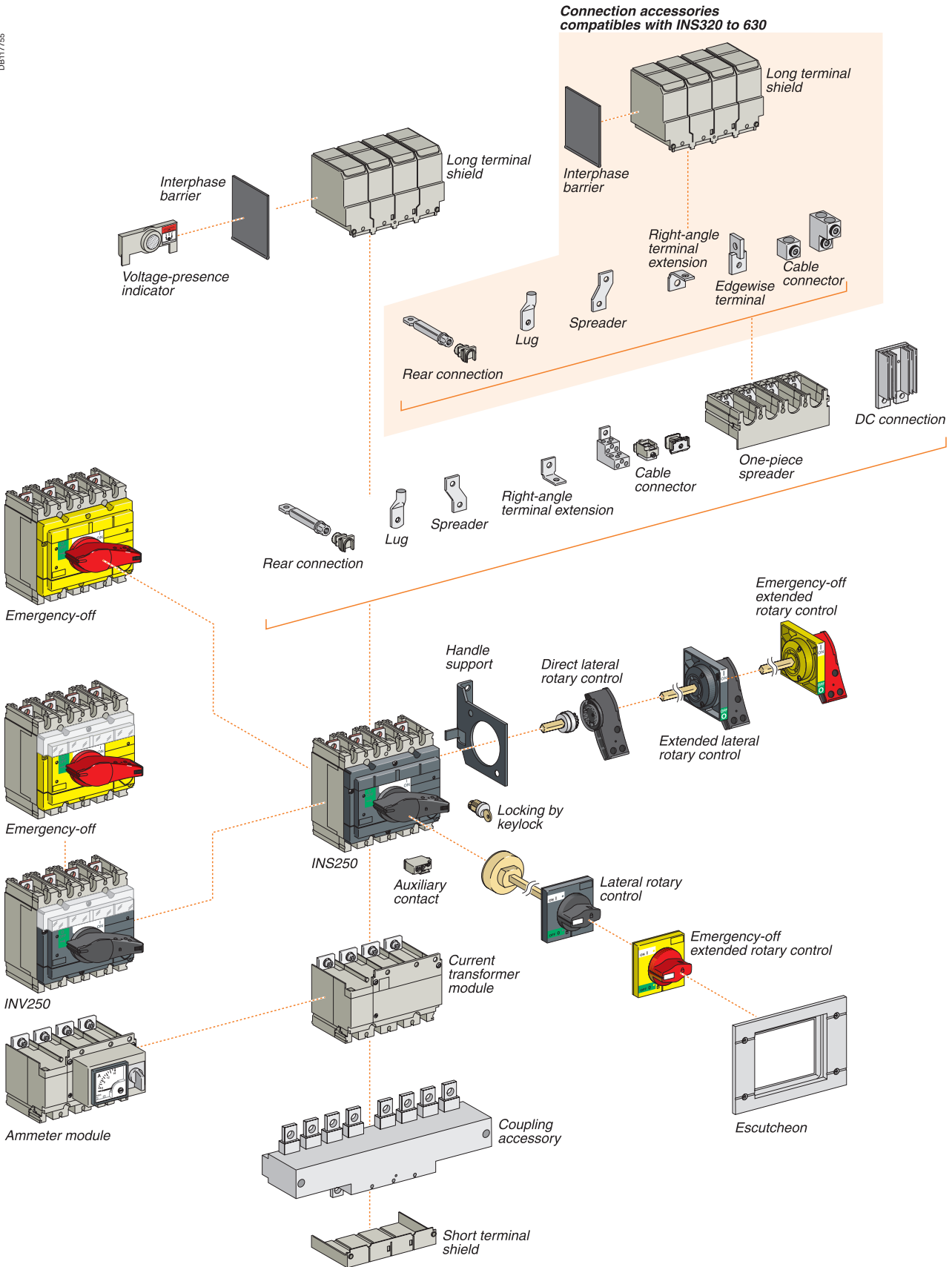



# Switch-disconnector selection

Interpact INS320 to 630

Interpact INV320 to 630

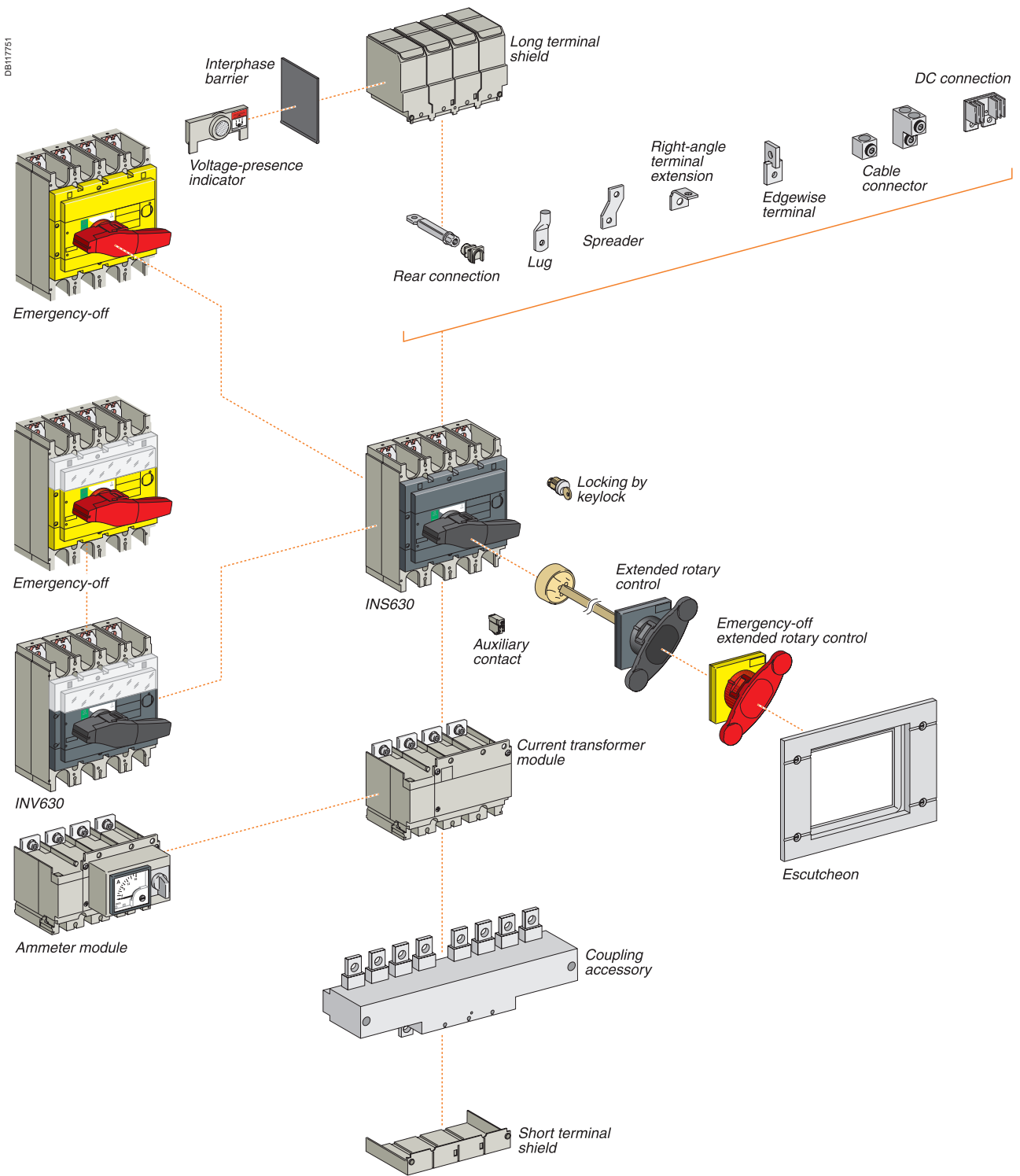

# Switch-disconnector selection

Interpact INS630b to 1600

Interpact INV630b to 1600

DB117754

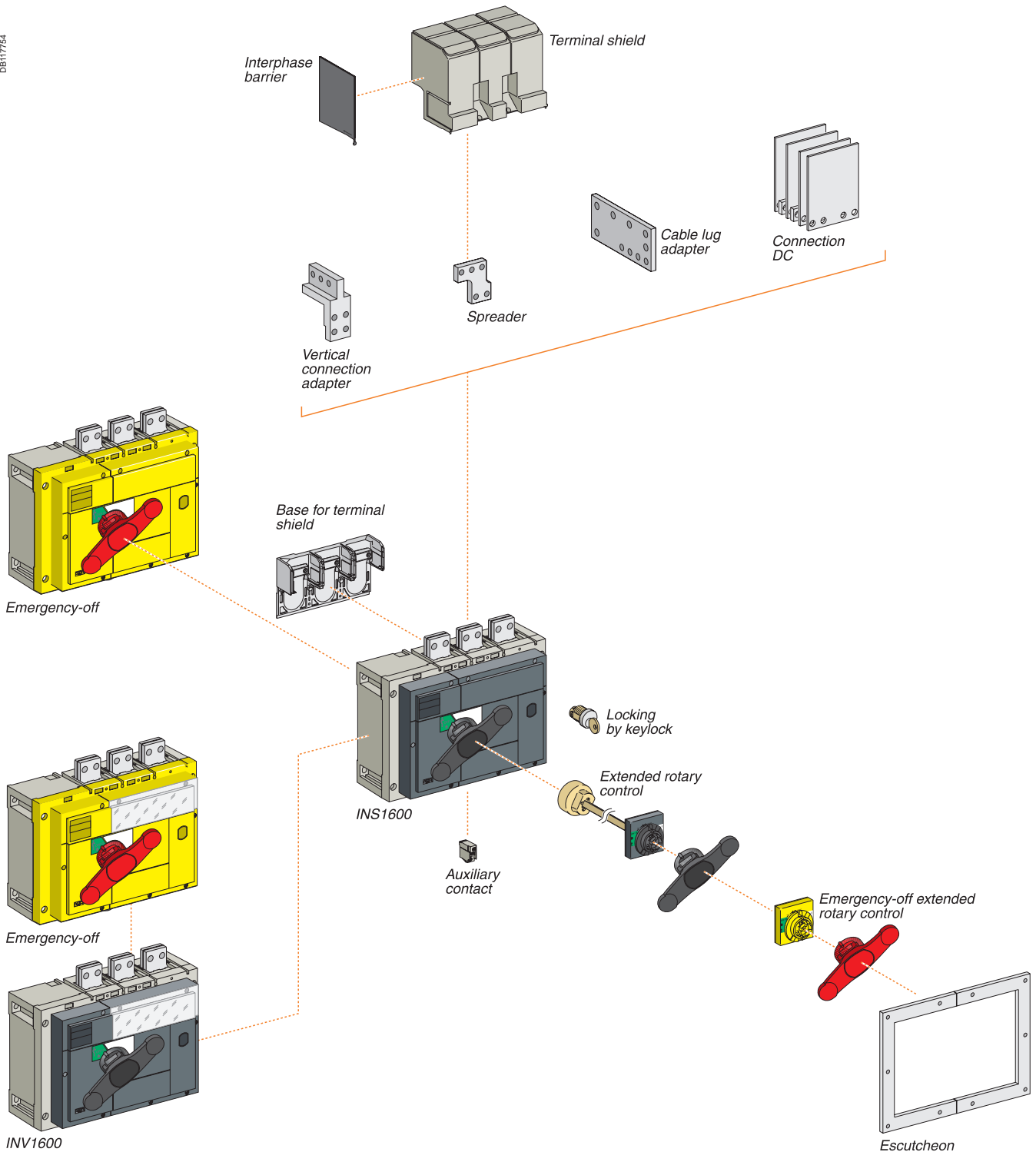

# Switch-disconnector selection

Interpact INS2000 to 2500

Interpact INV2000 to 2500

DB117756

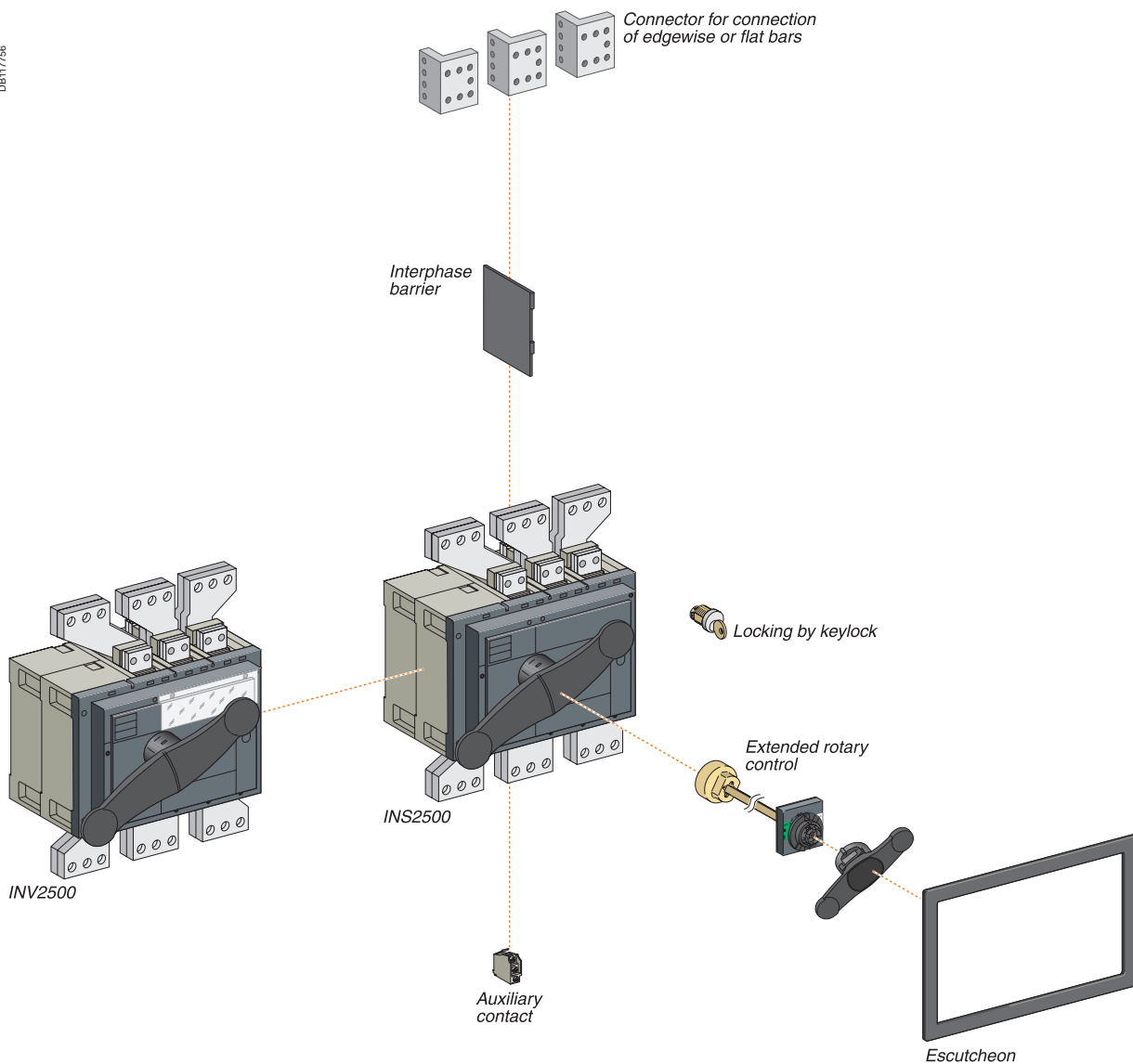



Interpact INV250 with ammeter module.

## Indications and measurement

### Ammeter module

For Interpact INS250 to 630 and INV100 to 630.

#### Function

Measures and displays the current of each phase (phase selection by a three-position switch on the front) on a dial-type ammeter.

#### Installation

- Connects directly to the downstream terminals of the switch-disconnector (except on a INS250 with a direct handle).
- Ammeter clips into module in any of four 90° positions, i.e. can be installed of devices mounted both vertically and horizontally.
- Degree of protection: IP40, IK04.
- Class II insulation between front and power circuits.

#### Electrical characteristics

Accuracy: class 4.5.

### Current-transformer module

For Interpact INS250 to 630 and INV100 to 630.

#### Function

The module enables direct connection of a measurement device such as an ammeter or a Digipact power meter (not supplied).

#### Installation

- Connects directly to the downstream terminals of the switch-disconnector.
- Degree of protection: IP40, IK07.
- Class II insulation between front and power circuits.
- Connection via six built-in terminals for cables with a cross-sectional area of 2.5 mm<sup>2</sup>.

#### Electrical characteristics

- Current transformer with 5 A secondary winding.
  - Class 3 for the following values of consumed output power.
- Accuracy:
- 100 A rating - 1.6 VA
  - 150 A rating - 3 VA
  - 250 A rating - 5 VA
  - 400/630 A rating - 8 VA.

### Current-transformer module with voltage measurement outputs

For direct connection of a digital power monitoring unit: Power Meter PM700, PM800, etc. (not supplied).

#### Installation

- Mounts directly on the downstream terminals of the circuit breaker.
- Degree of protection: IP40, IK04.
- Class II insulation of front with respect to the power circuits.
- Built-in connectors for cables from 1.5 to 2.5 mm<sup>2</sup>.

#### Electrical characteristics

- Rated operational voltage U<sub>e</sub>: 530 V.
- Frequencies of measured values: 50... 60 Hz.
- Three CTs with 5 A secondary windings for the rated primary current I<sub>N</sub>
- class 0.5 to 1 for rated power consumption values at the output:
  - 125 A, 150 A and 250 A ratings: class 1 for 1.1 VA
  - 400/600 A rating: class 0.5 for 2 VA
- use a cable of 2.5 mm<sup>2</sup> section up to 2.5 m long.
- Four voltage measurement outputs including protection with automatic reset
- voltage measurement output impedance 3500 W ±25 %, maximum current 1 mA.

### Voltage presence indicator

The indicator detects and indicates that circuit breaker terminals are supplied with power.

#### Installation

- In the long or short terminal shields, via the knockouts.
- Upstream or downstream of the circuit breaker.
- Degree of protection, IP40, IK04.

#### Electrical characteristics

Operates on all networks with voltages ranging from 220 et 550 V AC.



Auxiliary contacts for Interpact INS and INV

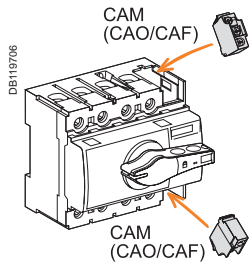

Interpact INS40 to 160.

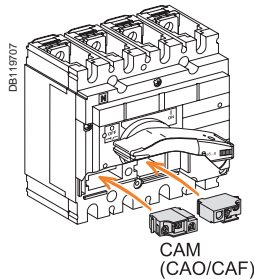

Interpact INS250 and INV100 to 250.

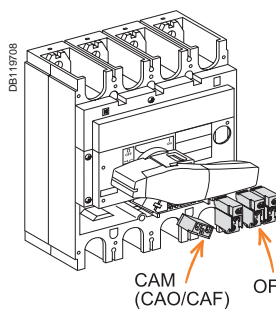

Interpact INS/INV320 to 630.

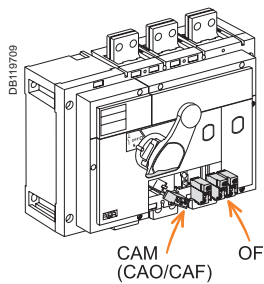

Interpact INS/INV800 to 1600.

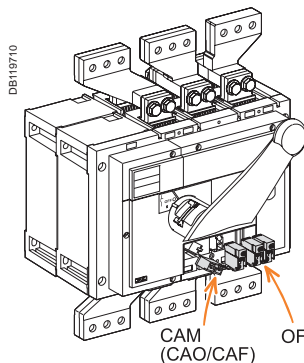

Interpact INS/INV2000 to 2500.

## Auxiliary contacts

### Interpact INS and INV

One or four common-point changeover contacts can be used to remote switch-disconnector status information for indications, electrical interlocking, relays, etc.

#### Functions

Each contact may be used for the following functions:

- OF (ON/OFF): indicates the position of the switch-disconnector poles
- CAM (early-make or early-break function): indicates the position of the handle. Used in particular for:

- CAO early-break switch (auxiliary contacts open before the main contacts), used, for example, to automatically open a circuit breaker or a contactor before opening the Interpact INS
- CAF early-make switch (auxiliary contacts close before the main contacts)
- switching of very small loads. A "low-level" version of the auxiliary contacts exists for switching very small loads (for example, to control a PLC or electronic circuits).

#### Standards

The auxiliary contacts comply with international standard IEC 60947-5-1.

#### Installation

They simply snap in under the auxiliaries cover (supplied as standard) of the switch-disconnector.

#### Insulation

Sealable auxiliary shield to protect against direct contact with power circuits.

#### Electrical characteristics of auxiliary contacts for Interpact INS and INV

	Standard				Low level				
	AC12	AC15	DC12	DC14	AC12	AC15	DC12	DC14	
Rated thermal current (A)	6				5				
Minimum load	10 mA at 24 V				1 mA at 4 V				
Utilisation category (IEC 60947-5-1)	AC12	AC15	DC12	DC14	AC12	AC15	DC12	DC14	
Operational current (A)	24 V	6	6	6	1	5	3	5	1
	48 V	6	6	2.5	0.2	5	3	2.5	0.2
	110 V	6	5	0.6	0.05	5	2.5	0.6	0.05
	200/240 V	6	4	-	-	5	2	-	-
	250 V	-	-	0.3	0.03	5	-	0.3	0.03
	380/440 V	6	2	-	-	5	1.5	-	-
	480 V	6	1.5	-	-	5	1	-	-
	660/690 V	6	0.1	-	-	-	-	-	-

### Interpact INS40 to 2500, INV100 to 2500

#### Possible combinations

Interpact	OF block	CAM block (CAO/CAF)
INS40 to 160	-	2
INS250	-	2
INS400 to 630	3	and 1
INS630b to 1600	3	and 1
INS2000 to 2500	3	and 1



Interpact INS160 with lateral direct rotary handle.

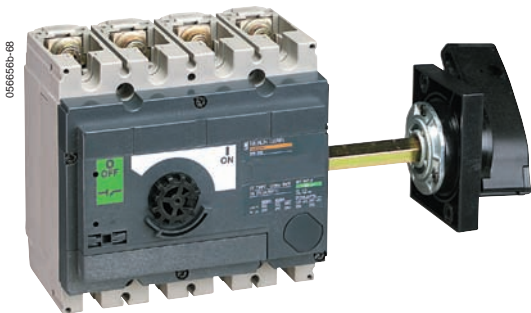

Interpact INS250 with lateral extended rotary handle.



Interpact INS630 with front extended rotary handle.



Interpact INS250 emergency-off version with front direct rotary handle.

## Rotary handle

### Interpact INS and INV

There are two types of rotary handle:

- direct rotary handle
- extended rotary handle.

There are two models:

- standard with a black handle
- with a red handle and yellow front for machine-tool control, in accordance with VDE standard.

	INS40-160	INS250 INV100-250	INS/INV 320-630	INS/INV 630b-1600	INS/INV 2000-2500
<b>Standard rotary handle</b>					
Front direct	Standard	Standard	Standard	Standard	Standard
Lateral direct	Standard	With conversion	No	No	No
Front extended	Optional	Optional	Optional	Optional	Optional
Lateral extended	Optional <sup>(1)</sup>	Optional	No	No	No
<b>Red and yellow rotary handle for emergency-off switch-disconnectors</b>					
Front direct	Standard	Standard	Standard	Standard	No <sup>(2)</sup>
Lateral direct	Standard	With conversion	No	No	No
Front extended	Optional	Optional	Optional	Optional	No <sup>(2)</sup>
Lateral extended	Optional <sup>(1)(3)</sup>	Optional <sup>(3)</sup>	No	No	No

<sup>(1)</sup> Two models for universal enclosures and for Prisma G enclosures.

<sup>(2)</sup> Emergency-off versions not available for INS/INV2000-2500.

<sup>(3)</sup> The basic switch-disconnector must be the emergency-off (red and yellow) version.

### Direct rotary handle

- Degree of protection IP40.IK07.
- The switch-disconnector may be locked in the OFF position by one to three padlocks, hasp diameter 5 to 8 mm (not supplied).

### Models

- Standard switch-disconnector: with black handle.
- Emergency-off version with red handle and yellow front for machine-tool control.

### Extended rotary handle

Makes it possible to operate the switch-disconnector, installed inside a switchboard, from the front or side of the switchboard. The extended rotary handle may be installed on the front or the side of the switch-disconnector. Degree of protection IP55.IK08.

### Operation

- Suitability for isolation is maintained.
- Door opening is prevented when the switch-disconnector is in ON position (for front handle only).
- The switch-disconnector may be locked in the OFF position by one to three padlocks, hasp diameter 5 to 8 mm (not supplied). Locking prevents opening of the switchboard door (for front handle only).

### Models

- Standard switch-disconnector: with black handle.
- Emergency-off: with red handle and yellow front for machine-tool control.

### Installation

The extended rotary handle is made up of:

- An assembly that replaces the direct rotary handle on the Interpact switch-disconnector (secured by screws).
- An assembly (handle and front plate) to be mounted on the door or the side of the switchboard. This assembly is always secured in the same position, whether the switch-disconnector is installed vertically or horizontally.
- An adjustable extension shaft (see p. C-6 to p. C-9).

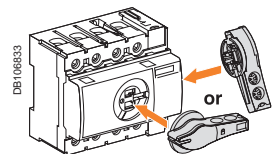

Direct rotary handle on INS40 to 160.

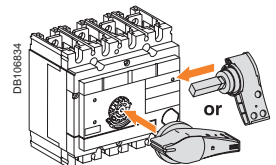

Direct rotary handle on INS250 and INV100 to 250.

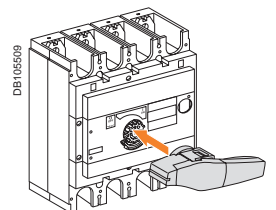

Direct rotary handle on INS/INV320 to 630.

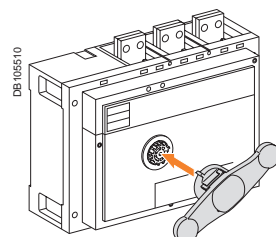

Direct rotary handle on INS/INV800 to 1600.

056649b-56



Padlocked Interpact INS250 switch-disconnector.

## Disabling device closing

### Padlocking

- INS40 to 2500 A.
- INV100 to 2500 A.
- Complete source-changeover assembly from 100 to 630 A.

### Switch-disconnectors may be locked in the OFF position

The handle is designed for locking by up to three padlocks (not supplied). Locking in the OFF position guarantees isolation as defined by the IEC 60947-3 standard. The handle may also be lead-sealed in the OFF position.

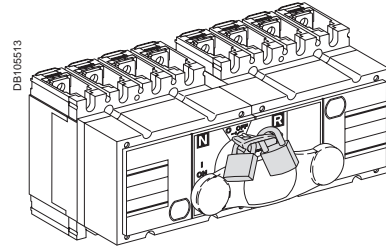
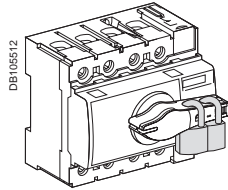

### Keylocking

- INS250-100 to 2500 A.
- INV100 to 2500 A.
- Complete source-changeover assembly from 100 to 630 A.

INS250 to 630, INV100 to 630 or INV1000 to 2500 switch-disconnectors may be locked in the OFF position using a keylock (optional) that may be installed in the hole prepared for that purpose on the front of the devices.

The key may not be removed when the switch-disconnector is in the ON position. Keylocks can also be fitted on switch-disconnectors equipped with extended rotary handles.

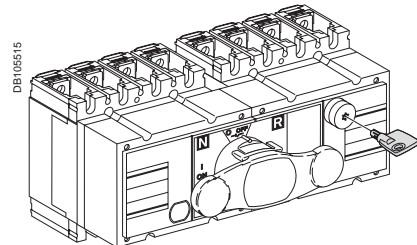
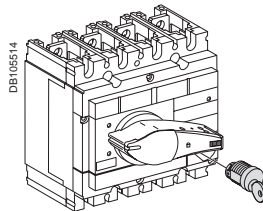

## INS/INV switch disconnectors

	INS40 to 80		INS80 to 160		INS250-100 to 250 INV100 to 250		INS320 to 630 INV320 to 630		INS630b to 1600 INV630b to 1600		INV2000 to 2500 INS2000 to 2500	
	OFF	ON	OFF	ON	OFF	ON	OFF	ON	OFF	ON	OFF	ON
Locking by padlocks	■	□	■	□	■	□	■	□	■	□	■	□
Locking by keylock	-	-	-	-	■	□	■	□	■	□	■	□
Door locking <sup>(1)</sup>	-	■	-	■	-	■	-	■	-	■	-	■
Door lock defeat <sup>(1)</sup>	-	■ <sup>(2)</sup>	-	■ <sup>(2)</sup>	-	■ <sup>(2)</sup>	-	■ <sup>(2)</sup>	-	■ <sup>(2)</sup>	-	■ <sup>(2)</sup>
Door locking device padlocked <sup>(1)</sup>	■	-	■	-	■	-	■	-	■	-	■	-
Lead-sealable handle	■	□	■	□	■	□	■	□	■	□	■	□

## Complete source changeover assembly

	INS250-100 to 250		Replacement ON	INS320 to 630		Replacement ON
	Normal ON	OFF		Normal ON	OFF	
Locking by padlocks	□	■	□	□	■	□
Locking by keylock	-	■	-	-	■	-
Door locking <sup>(1)</sup>	■	-	■	■	-	■
Door lock defeat <sup>(1)</sup>	■ <sup>(2)</sup>	-	■ <sup>(2)</sup>	■ <sup>(2)</sup>	-	■ <sup>(2)</sup>
Door locking device padlocked <sup>(1)</sup>	-	■	-	-	■	-
Lead-sealable handle	□	■	□	□	■	□

■ Standard.

□ By simple modification of the standard rotary handle.

<sup>(1)</sup> Using a special tool.

<sup>(2)</sup> With extended rotary control.

A source-changeover system is made up of two switch-disconnectors or circuit breakers that are mechanically interlocked.

The mechanism prevents the simultaneous connection (even transient) of both sources. Switching from one source to the other can be achieved by:

- a keylock-type interlocking system
- a mechanical interlocking system
- a complete source-changeover assembly.

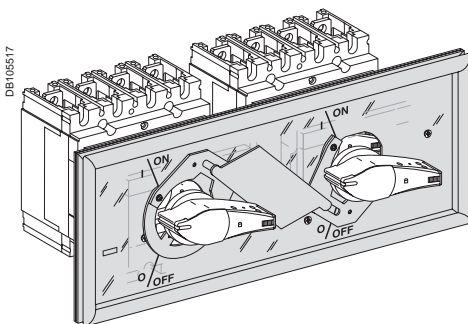
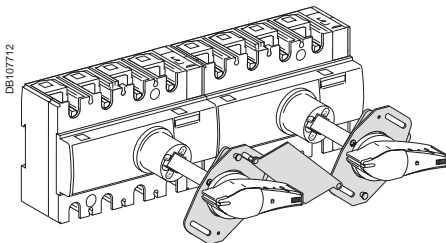
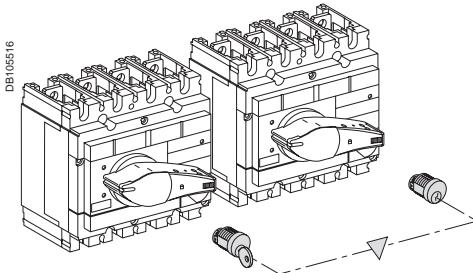

### Possible positions

Normal	1	0	0
Replacement	0	1	0

Source-changeover	INS40...160	INS250	INS320...630	INS630b...2500
		INV100...250	INV320...630	
By keylock	-	■	■	■
Mechanical	■	■	■	-
Complete assembly	-	■	■	-

### Interlocking of two devices using keylocks and a captive key

Interlocking is based on two identical keylocks with a single key and a keylock adapter (different for each device). This solution enables interlocking between two devices that are physically distant or that have very different characteristics.

### Interlocking of two devices with rotary handles

The direct or extended rotary handles are padlocked with the devices in the OFF position. The mechanism prevents simultaneous closing of the devices, but allows them to be opened.

### Possible combinations of "Normal" and "Replacement" source INS40 to 160 switch-disconnectors

"Normal N" Interpact INS <sup>(1)</sup>	"Replacement" R					
	INS40	INS63	INS80	INS100	INS125	INS160
<b>INS40</b>						
Ratings 40 A	■	■	■	■	■	■
<b>INS63</b>						
Ratings 63 A	■	■	■	■	■	■
<b>INS80</b>						
Ratings 80 A	■	■	■	■	■	■
<b>INS100</b>						
Ratings 100 A	■	■	■	■	■	■
<b>INS125</b>						
Ratings 125 A	■	■	■	■	■	■
<b>INS160</b>						
Ratings 160 A	■	■	■	■	■	■

(1) With extended rotary handles only.

### Possible combinations of "Normal" and "Replacement" source INS/INV100 to 250 switch-disconnectors

"Normal N" Interpact INS /INV <sup>(2)</sup>	"Replacement" R			
	INS250-100 INV100	INS250-160 INV160	INS250-200 INV200	INS250-250 INV250
<b>INS250-100/INV100</b>				
Ratings 100 A	■	■	■	■
<b>INS250-160/INV160</b>				
Ratings 160 A	■	■	■	■
<b>INS250-200/INV200</b>				
Ratings 200 A	■	■	■	■
<b>INS250-250/INV250</b>				
Ratings 250 A	■	■	■	■
<b>INS320/INV320</b>				
Ratings 320 A	□			□
<b>INS400/INV400</b>				
Ratings 400 A				
<b>INS500/INV500</b>				
Ratings 500 A				
<b>INS630/INV630</b>				
Ratings 630 A	□			□

□ 250 A and 630 A ratings can be mixed by using INS320/630 rotary handle interlocking system.

(2) Possible with INV, but visible-break function is significantly impaired.



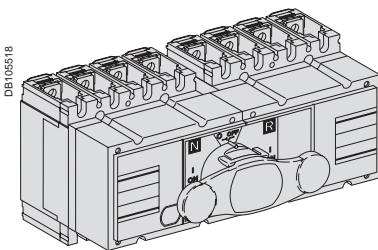
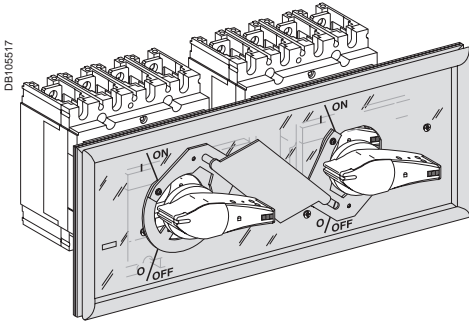

## Interlocking of two devices with rotary handles

Possible combinations of "Normal" and "Replacement" source  
INS/INV320 to 630 switch-disconnectors

"Normal N" Interpact INS /INV (1)	"Replacement" R			
	INS320 INV320	INS400 INV400	INS500 INV500	INS630 INV630
<b>INS250-100/INV100</b> Ratings 100 A	<input type="checkbox"/>	<input type="checkbox"/>	<input type="checkbox"/>	
<b>INS250-160/INV160</b> Ratings 160 A				
<b>INS250-200/INV200</b> Ratings 200 A				
<b>INS250-250/INV250</b> Ratings 250 A	<input type="checkbox"/>			<input type="checkbox"/>
<b>INS320/INV320</b> Ratings 320 A	<input checked="" type="checkbox"/>	<input checked="" type="checkbox"/>	<input checked="" type="checkbox"/>	<input checked="" type="checkbox"/>
<b>INS400/INV400</b> Ratings 400 A	<input checked="" type="checkbox"/>	<input checked="" type="checkbox"/>	<input checked="" type="checkbox"/>	<input checked="" type="checkbox"/>
<b>INS500/INV500</b> Ratings 500 A	<input checked="" type="checkbox"/>	<input checked="" type="checkbox"/>	<input checked="" type="checkbox"/>	<input checked="" type="checkbox"/>
<b>INS630/INV630</b> Ratings 630 A	<input checked="" type="checkbox"/>	<input checked="" type="checkbox"/>	<input checked="" type="checkbox"/>	<input checked="" type="checkbox"/>

250 A and 630 A ratings can be mixed by using INS320/630 rotary handle interlocking system.  
(1) Possible with INV, but visible-break function is significantly impaired.

## Complete source-changeover assembly for two switch-disconnectors

These assemblies provide an easy way to implement source changeover functions with:

- a single 3-position rotary handle that controls the two switch-disconnectors (Normal source ON, OFF, Replacement source ON)
- a smaller size, taking up less room in the switchboard.

A complete source changeover assembly can be ordered with a single catalogue number.

Possible combinations of "Normal" and "Replacement" source switch-disconnectors

"Normal N"	"Replacement" R							
	INS250-100	INS250-160	INS250-200	INS250-250	INS320	INS400	INS500	INS630
<b>INS250-100</b> Ratings 100 A	<input checked="" type="checkbox"/>							
<b>INS250-160</b> Ratings 160 A		<input checked="" type="checkbox"/>						
<b>INS250-200</b> Ratings 200 A			<input checked="" type="checkbox"/>					
<b>INS250-250</b> Ratings 250 A				<input checked="" type="checkbox"/>				
<b>INS320</b> Ratings 320 A					<input checked="" type="checkbox"/>			
<b>INS400</b> Ratings 400 A						<input checked="" type="checkbox"/>		
<b>INS500</b> Ratings 500 A							<input checked="" type="checkbox"/>	
<b>INS630</b> Ratings 630 A								<input checked="" type="checkbox"/>

With Interpact INS/INV switch-disconnectors, it is easy to create a large number of series pole arrangements using prefabricated connections mounted on site during equipment installation.

## Series connection of poles for direct current applications

### Examples of series connection

#### Three-pole devices

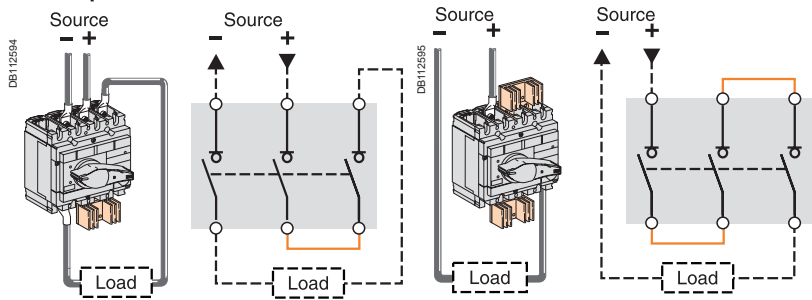
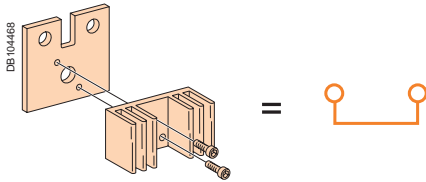

#### Four-pole devices

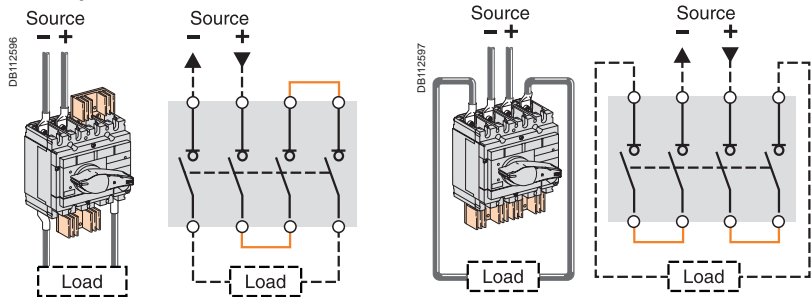

One type of connection per framesize, two catalogue numbers for all series connections.

### Great flexibility for connections

- Indifferent connection of polarities, from left to right or right to left.
- Indifferent connection of upstream and downstream cables to top or bottom terminals.
- Series connection of poles is possible by upstream/downstream connections. Creation of the connections is the responsibility of the panel builder or the installer.

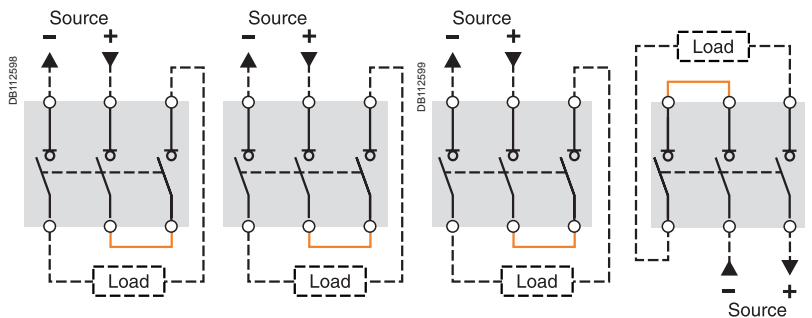

Indifferent connection of polarities.

Upstream/downstream connections to top or bottom connectors.

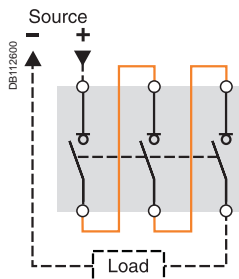

Series connection of poles is possible by upstream/downstream connections (user made).

The exceptional performance levels of Interpact INS/INV switch-disconnectors mean the poles can be parallel connected. This technique virtually doubles, triples or quadruples the current rating depending on the type of circuit breaker and thus reduces the cost of solutions.

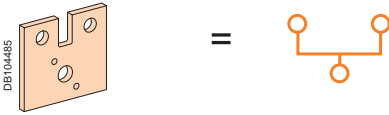

Parallel pole connection accessories are identical to those for series connections. They are equipped with heat sinks. Customer connections are made directly to the connection plates after removing the heat sinks.



Specific connections are required for parallel connection of three poles.

## Parallel connection of poles for direct current applications

### Examples of parallel connection

#### Three-pole devices

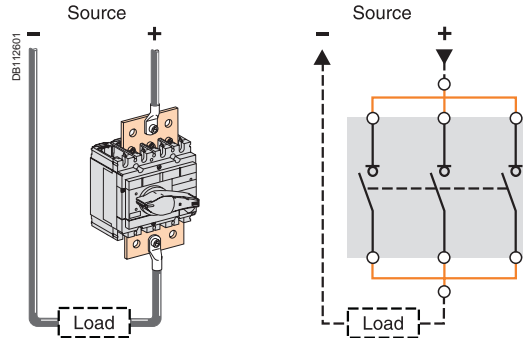

#### Four-pole devices (2 x 2 poles in parallel)

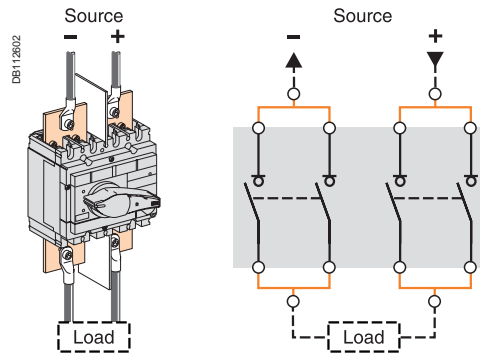

### It is possible to mix series and parallel connections

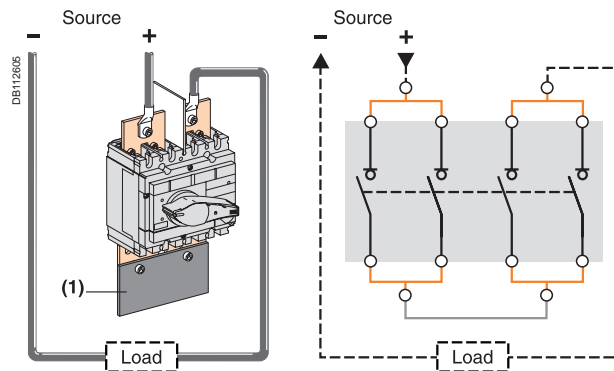

**Note:** creation of the additional connection (1) is the responsibility of the panel builder or the installer.

#### Great flexibility for connections

- Indifferent connection of polarities, from left to right or right to left.
- Indifferent connection of upstream and downstream cables to top or bottom terminals.

## Solutions depending on the distribution system and the voltage

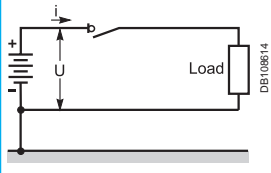
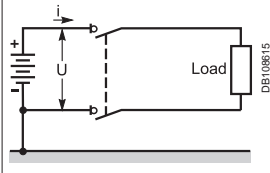
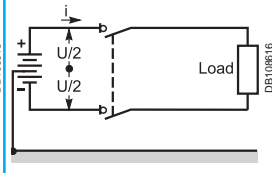
Type of distribution system			
Type	Earthed		Isolated
Source	One polarity (negative here) connected to earth (or exposed conductive parts)		Mid-point connected to earth
Protected polarities	1 (disconnection of 1P)	2 (disconnection of 2P)	2
Diagrams, connection method			

## Series connection of poles

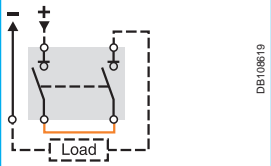
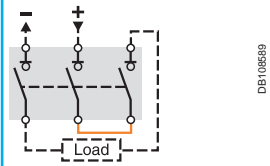
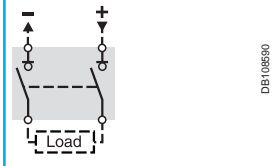
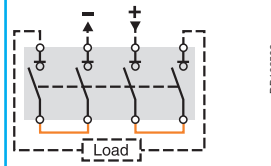
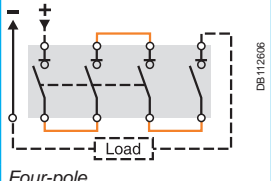
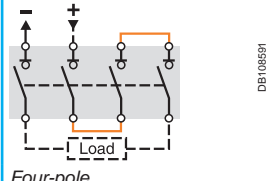
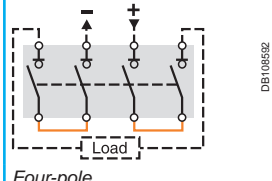
Selection of switch-disconnectors and pole connection				
Interpact INS/INV				
24 V ≤ Un ≤ 125 V	 Two-pole (1).	 Three-pole.	 Two-pole (1).	 Four-pole.
125 V < Un ≤ 250 V	 Four-pole.	 Four-pole.	 Four-pole.	Not applicable

(1) A 3P switch-disconnectors can be used if a 2P version does not exist. In this case, the central pole is not connected.

## Parallel connection of poles

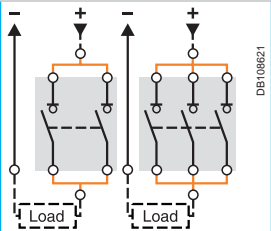
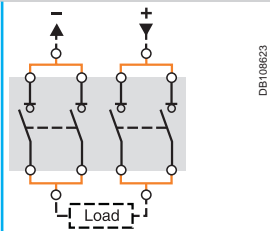
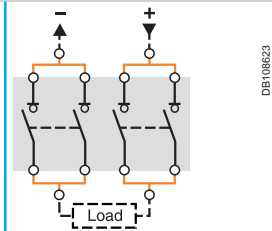
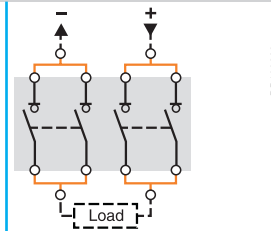
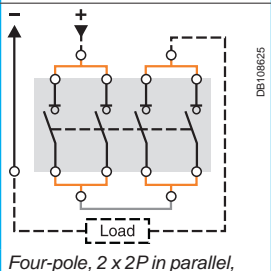
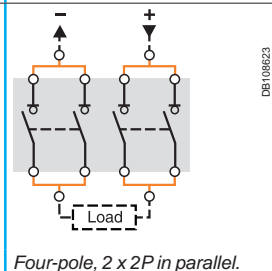
Selection of switch-disconnectors and pole connection				
Interpact INS/INV				
Un ≤ 63 V	 Two, three-pole, 2, 3P in parallel, four-pole, 4P in parallel.	 Four-pole, 2 x 2P in parallel.	 Four-pole, 2 x 2P in parallel.	 Four-pole, 2 x 2P in parallel.
63 V < Un ≤ 125 V	 Four-pole, 2 x 2P in parallel, connected in series.	Not applicable	 Four-pole, 2 x 2P in parallel.	Not applicable

0653844-56



One-piece spreader.

## One-piece spreader

Connection of large cables may require an increase in the distance between the switch-disconnector terminals. The one-piece spreader is an accessory that can also be fitted on Compact NSX/NS circuit breakers. It offers the following features:

- increases the pitch of the switch-disconnector terminals to correspond to that of the upstream device
- compatible with all the connection and insulation accessories available for the upstream device (connectors, terminal extensions, etc.)
- enhances insulation between phases in comparison with standard spreaders.

	INS250 INV100 to 250	INS320 to 630 INV320 to 630
Pitch <b>without</b> spreaders (mm)	35	45
Pitch <b>with</b> standard spreaders (mm)	45	52.5 or 70
Pitch <b>with</b> one-piece spreader (mm)	45	-

## Mounting

When equipped with a one-piece spreader, INS and INV switch-disconnectors may be installed either at the back of a switchboard or on the front panel with a front alignment base.

- Devices with different frame sizes can thus be aligned in the switchboard.
- The same mounting plate can be used for all devices (including Compact NSX/NS circuit breakers).

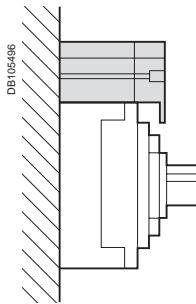

Mounting at the back of a switchboard.

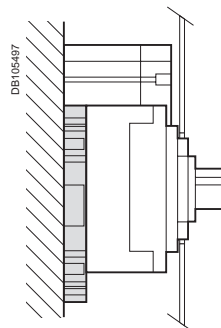

Mounting on the front panel with a front alignment base.

DBI05495

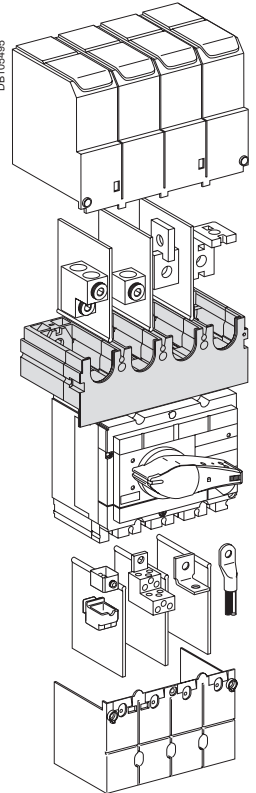

Connection and insulation accessories are identical to those for Compact NSX/NS.

PD390942R



### Multi-stage distribution block 125 A

**Electrical characteristics:**

- rated operating current:  $I_e (40\text{ }^\circ\text{C}) = 125\text{ A}$
- rated insulation voltage:  $U_i = 500\text{ V}$
- rated short-time withstand current:  $I_{cw} = 3.5\text{ kA rms/1s}$
- peak withstand current:  $I_{pk} = 20\text{ kA}$
- rated impulse withstand voltage:  $U_{imp} = 8\text{ kV}$ .

**Mounting:**

- clipped onto Multifix or symmetrical rail
- screwed on plain or slotted plate.

**Supplied with:**

- transparent, insulating cover
- mounting hardware.

041153A-32

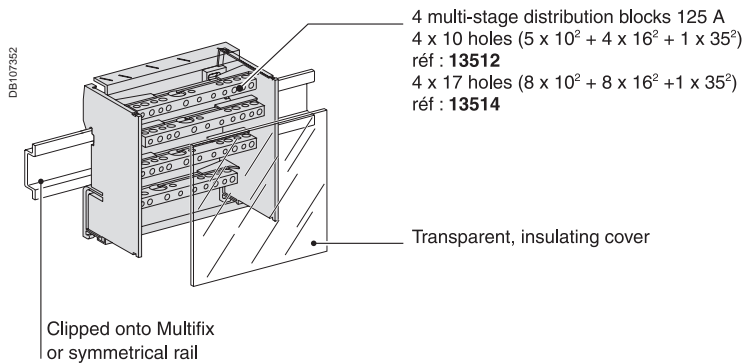
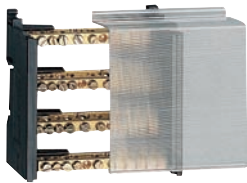

PD390600R



### Distribution block 125 to 160 A

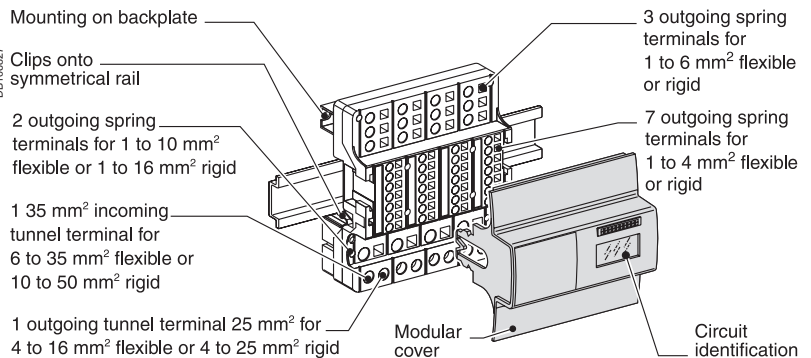

Distribloc 125 A.

DB107342

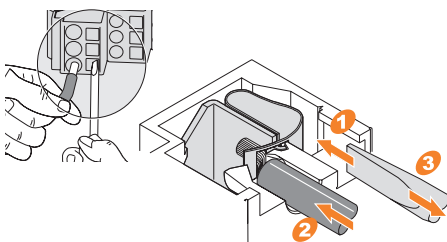

Cable connection.

**General**

Downstream circuits are connected from the front, to spring terminals. Contact pressure automatically adapts to the size of the conductor. It does not depend on the operator. Contacts are insensitive to vibrations and thermal variations. Only one cable (flex ble or rigid, without a metal ferrule) can be inserted in a spring terminal. Degree of protection: IPxxB.

**Advantages:**

- a reliable electrical connection, no maintenance required (tightness guaranteed over time)
- very fast connection
- easy phase balancing
- rewiring is very easy if the switchboard is expanded or modified.

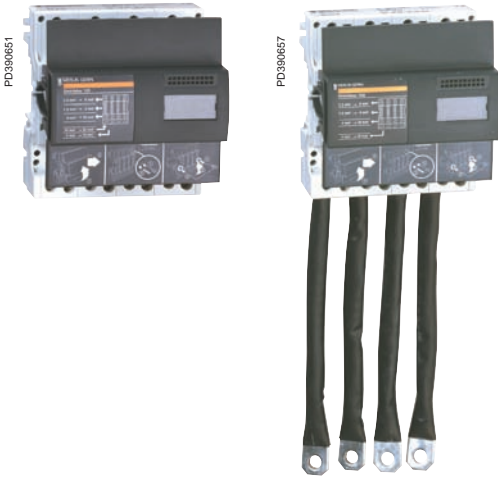

**Distribution block 125 to 160 A**

Made up of:

- a fully insulated, one-piece distribution block complying with the degree of protection IPxxB (protection against direct contacts)
- a modular cover.

The design of the front (45 mm nose) blends perfectly into a row comprising modular devices.

**Electrical characteristics**

- Rated insulation level:  $U_i = 750\text{ V}$ .
- Rated operational current  $I_e (40^\circ\text{C})$ :
  - 125 A for the 125 A Distribloc
  - 160 A for the 160 A Distribloc with its prefabricated connection for INS160 or NSA160.
- Short-circuit withstand current: the reinforced breaking capacity due to cascading in circuit-breaker combinations is maintained. The worst-case situations have been tested.
- Complies with the low-voltage device standard IEC 60947.7.1 and/or IEC 60439.1
- impulse withstand voltage  $U_{imp} = 8\text{ kV}$ .

**Supply**

- Tunnel terminal on 125 A Distr bloc 125 for 6 to 35<sup>sq</sup> flexible cables (10 to 35<sup>sq</sup> rigid cables).
- The 160 A Distribloc is supplied with a prefabricated flexible connection. It is designed for an INS100/160 or NSA160 switch-disconnector, installed on the left or right.

**Distribution (125 and 160 A Distribloc)**

- Spring terminals:
  - 2 outgoing from 1 to 10<sup>sq</sup>, flexible or rigid
  - 3 outgoing from 1 to 6<sup>sq</sup>, flexible or rigid
  - 7 outgoing from 1 to 4<sup>sq</sup>, flexible or rigid.
- Tunnel terminals:
  - 1 outgoing from 4 to 16<sup>sq</sup>, flexible (4 to 25<sup>sq</sup> rigid).

**Supply**

- An identification label
- Adhesive labels for phase identification
- A prefabricated flexible connection for the INS160 or NSA160 (160 A Distribloc only).

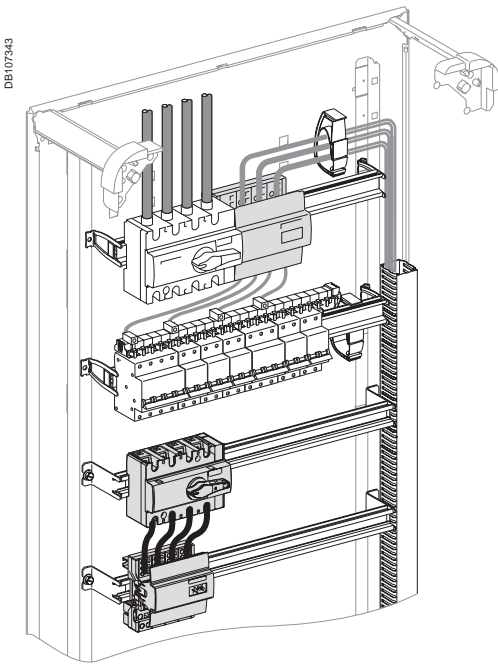

**Accessories**

- Set of four flexible connections, 35<sup>sq</sup>, L = 210 mm.
- To supply a 125 A Distr bloc from an NG125 or an INS125.

PD306549

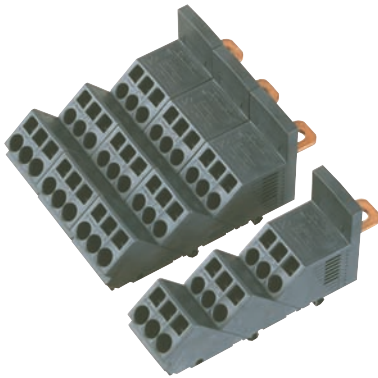

## 250 A Polybloc distribution block

### General

Downstream circuits are connected from the front, without screws, to spring terminals. Contact pressure automatically adapts to the size of the conductor (minimum size = 1 mm<sup>2</sup>). Contacts are insensitive to vibrations and thermal variations.

Only one cable (flexible or rigid, without a metal ferrule) can be inserted in a spring terminal.

Degree of protection: IPxxB.

### Advantages of spring terminals

- A reliable electrical connection, no maintenance required.
- The fast connections make phase balancing very easy.
- Rewiring is very easy if the switchboard is expanded or modified.

### Applications

The Polybloc distribution block is designed for installation directly downstream of Compact circuit breakers and Interpact switch-disconnectors devices up to 250 A. It can be rapidly mounted in the horizontal position. Electrical connections are made directly to the device terminals.

It has the same width as the devices and does not take up any additional space in the switchboard.

The connection terminals are slanted to facilitate cable entry and not exceed the bending radius of the flexible and rigid cables.

### Electrical characteristics

The electrical characteristics are perfectly compatible with the connected devices. Neither the temperature derating curves nor the performance levels of the circuit breakers and switch-disconnectors are altered.

- Rated insulation level  $U_i = 750 \text{ V}$ .
- Short-circuit withstand current: the reinforced breaking capacity due to cascading in circuit-breaker combinations is maintained. The worst-case situations have been tested.
- Impulse withstand voltage  $U_{imp} = 8 \text{ kV}$ .

### Supply

Directly to the terminals of the Compact NSX/NS and Interpact INS devices up to 250 A.

### Distribution

Via cables, up to six 10 mm<sup>2</sup> cables and three 16 mm<sup>2</sup> cables per phase.

### Installation

Directly on the mounting plates of horizontally mounted Compact NSX/NS100/250 and Interpact INS250 devices in the enclosures.

It can also be mounted downstream of vertically mounted Compact NSX/NS100/250 and Interpact INS250 devices in the enclosures. In this case, the Polybloc is mounted on a depth-adjustable modular rail (03002 System G) or (03402 System P).

DE107342

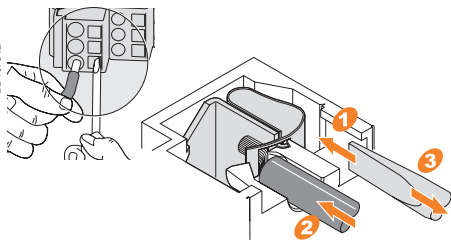

DB107345

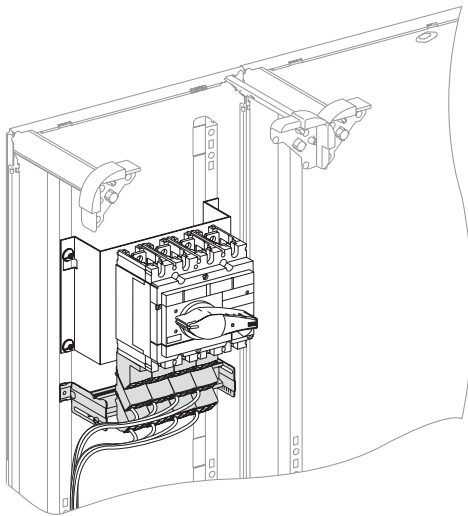

Vertically mounted Polybloc on a depth-adjustable modular rail (03402) in a cubicle (System G).

DB107347

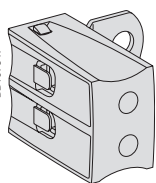

### Accessories

- Special connection blocks can be added to Polybloc 250 A distribution blocks for connection of two 35 mm<sup>2</sup> cables per phase via screw terminals.



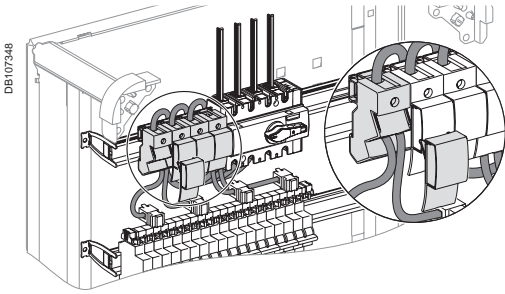

Three 160 A Polybloc distribution blocks in the vertical position on a modular rail, supplied by an INS160.

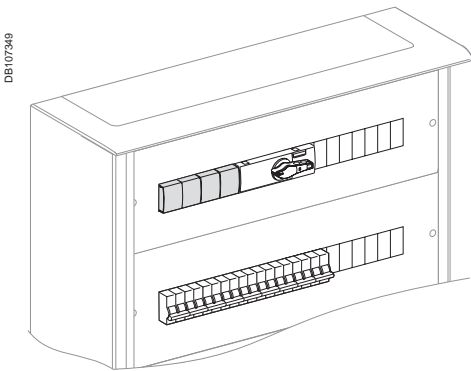

160 A Polybloc distribution block in a front plate cut-out.

### 160 A Polybloc distribution block

The 160 A Polybloc is made up of individual elements that can be used alone or with others to make two-pole, three-pole or four-pole distribution blocks.

Mounting is very fast. It clips onto a modular rail and is supplied by cables via a tunnel terminal.

The connection spring terminals are slanted to facilitate cable entry and bending of the flexible and rigid cables.

It is supplied with a cover that also guides the cables.

#### Electrical characteristics

- Rated insulation level  $U_i = 750\text{ V}$ .
- Short-circuit withstand current: the reinforced breaking capacity due to cascading in circuit-breaker combinations is maintained. The worst-case situations were tested. The electrical characteristics are perfectly compatible with the connected devices. Neither the temperature derating curves nor the performance levels of the circuit breakers and switch-disconnectors are altered.
- Impulse withstand voltage  $U_{imp} = 8\text{ kV}$ .

#### Supply

Direct to a tunnel terminal, for cables up to  $70\text{ mm}^2$ .

#### Distribution

Via cables, up to six  $16\text{ mm}^2$  cables.

#### Installation

The blocks clip onto a modular rail.

05F063R0-57

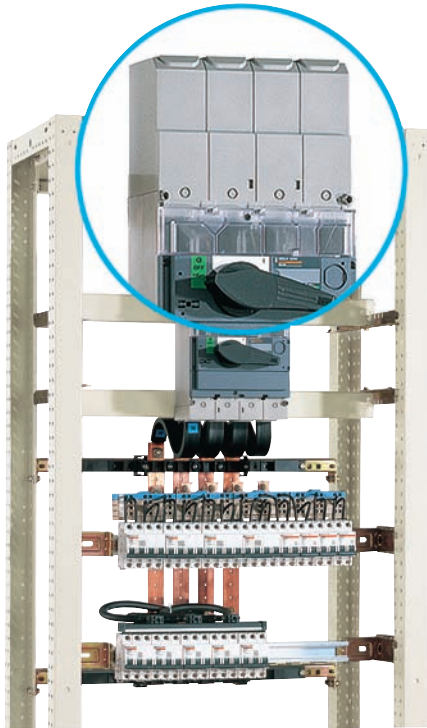

If  $500\text{ V} \leq U \leq 690\text{ V}$ , interphase-barrier or long terminal shields are mandatory.

## Insulation of live parts

### Terminal shields for INS and INV switch-disconnectors

Lead-sealable insulation accessories used to protect against direct contact with power circuits.

- Degree of protection: IP40, IK07.
- Supplied with lead-sealing accessories.

### Interphase-barrier for INS/INV

- Safety accessories providing maximum insulation between the phases of the power connection.
- Easy installation by snapping into the case.
- May be combined with all other connection accessories, except the terminal shields and terminal shrouds.

### Terminal shrouds for INS40 to INS160

These insulation accessories are used for protection against direct contact with live connection screws. It is also possible to attach an insulating plate (not supplied) to the shrouds to avoid any contact with the power conductors.

### Spare viewport for Interpact INV switch-disconnectors

Viewports are darkened by the electrical arc. A new viewport may be installed to maintain the visible-break function.

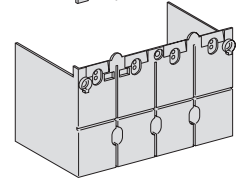
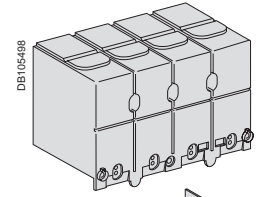

Terminal shields for Interpact INS and INV.

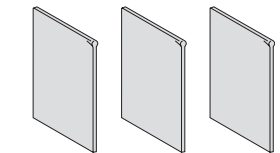
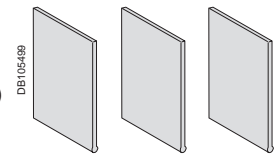

Interphase-barrier for Interpact INS and INV.

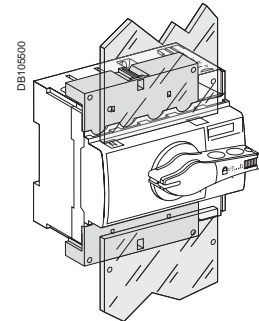

Terminal shrouds for Interpact INS40 to 160 (with insulating plate to avoid contact with the conductors).

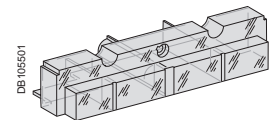

Spare viewport for Interpact INV.

DE105511

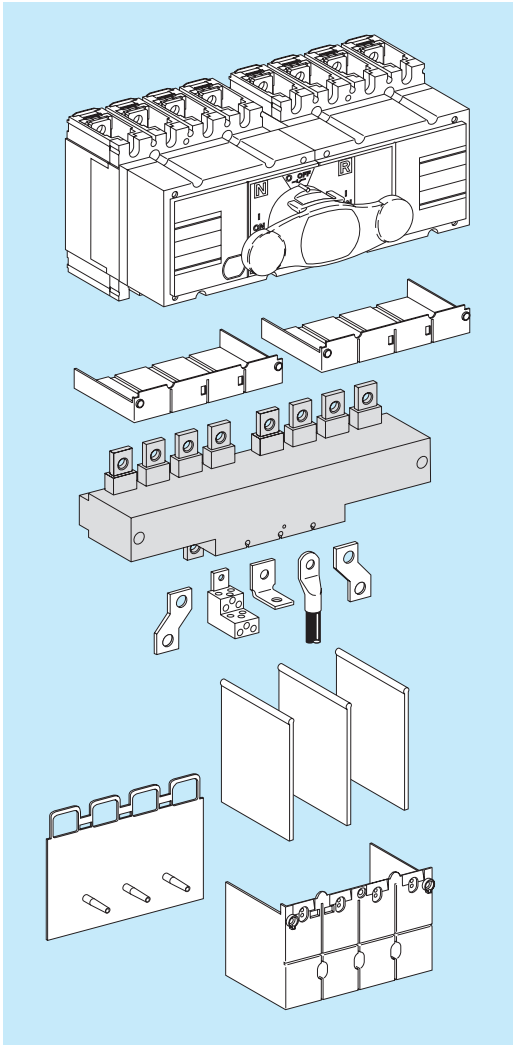

### Coupling accessory for complete source-changeover assembly

This accessory simplifies connection of bars or cables with lugs when coupling two Compact NSX/NS100 to 630 circuit breakers or two Interpact INS/INV100 to 630 switch-disconnectors of the same size.

Pitch between outgoing terminals:

- Interpact INS250 and INV100 to 250: 35 mm
- Interpact INS/INV320 to 630: 52.5 mm
- Compact NSX/NS100 to 250: 35 mm
- Compact NSX/NS400 to 630: 52.5 mm.

### Connection and insulation accessories

The coupling accessory may be fitted with the same connection and insulation accessories as the coupled circuit breakers or switch-disconnectors.

#### Possible combinations

#### Downstream coupling

	Possible	Pitch of outgoing terminals (mm)
<b>Manual source-changeover</b>		
INS250 (100 to 250 A) with rotary handle	■	35
NSX/NS100/250 with rotary handle	■	35
NSX/NS100/250 on mounting plate with toggle	■	35
INS400/630 (320 to 630 A) with rotary handle	■	52.5
NSX/NS400/630 with rotary handle	■	52.5
NSX/NS400/630 on mounting plate with rotary handle	■	52.5
<b>Complete source-changeover assembly</b>		
INS250 (100 to 250 A) complete assembly	■	35
INS400/630 (320 to 630 A) complete assembly	■	52.5
<b>Remote-operated source-changeover</b>		
NSX/NS100/250	■	35
NSX/NS400/630	■	52.5

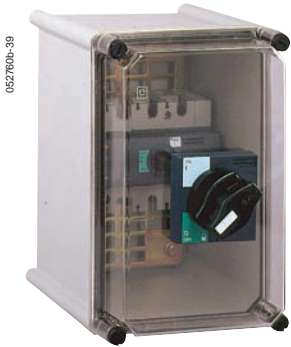

052760b-39

Local isolation enclosure.

Interpact INS and INV switch-disconnectors offer a number of rational installation solutions to optimise available space inside enclosures. They may be installed in individual enclosures or as incomers in power distribution or control panels.

- Interpact INS40 to 160 switch-disconnectors have a standard 45 mm high front and may be clipped onto a Multifix or symmetrical rail. They may be installed in all Multi 9 modular enclosures, including Pragma, Prisma, etc.
- Interpact INS250 to 630 and INV100 to 630 switch-disconnectors may be installed on mounting plates or rails. Installation as incomers in Prisma power distribution cubicles is very flexible:
  - the mounting plates are the same as those used for Compact NSX/NS circuit breakers and are identical for direct and extended handles
  - installation in 300 mm ducts is possible for ratings up to 630 A.

### Individual enclosures

- Each individual enclosure includes:
  - a door with a cut-out
  - a mounting plate
  - accessories required for extended front or lateral rotary handle
  - removable plates (without holes) for cable entry.
 The Interpact INS switch-disconnector must be order separately.

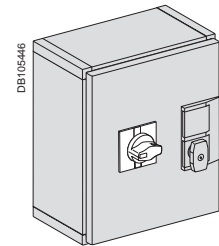

DB105446

Heavy-duty individual enclosure (sheet metal or plastic).

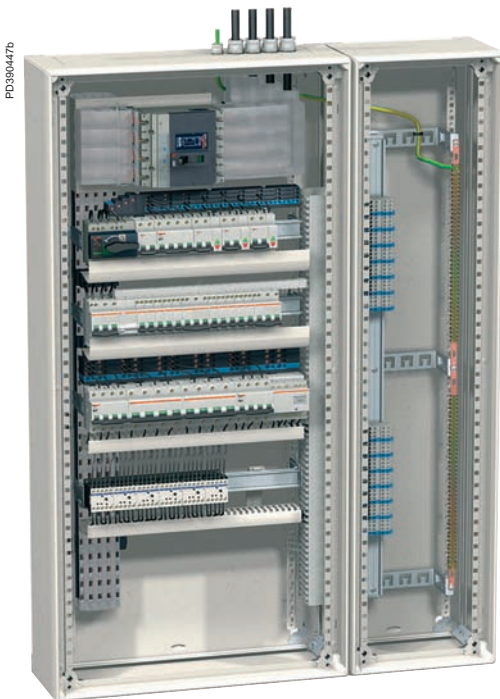

PD380447b

Power distribution incomer in a Prisma cubicle.

### Pragma modular enclosures

- The enclosures in the Pragma range are:
  - made of self-extinguishing insulating material
  - supplied with all accessories (terminal blocks, blanking plates, etc.)
  - rated class 2.

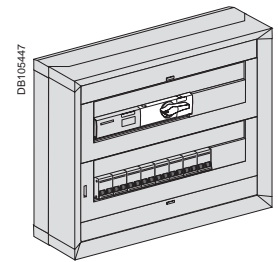

DB105447

Interpact INS40 on a symmetrical rail.

### Prisma metal cubicles and enclosures

- The metal cubicles and enclosures in the Prisma range are highly adaptable to the type of installation:
  - basic cubicle or enclosure
  - multifix rail
  - modular front plates
  - distribution accessories
  - ducts for running cables or installing terminals
  - plain or transparent doors.



056693b-59

Power distribution incomer in a Prisma Plus System G IP55 cubicle.

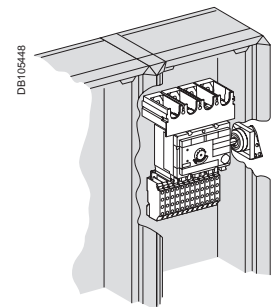

DB105448

Installation in a 300 mm duct.

## Front-panel escutcheons

**Escutcheons for switch-disconnectors and ammeter modules**  
Mounted on switchboard panel from the front using four screws.

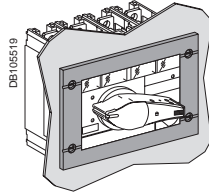

Escutcheon for switch-disconnectors.

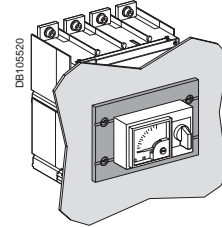

Escutcheon for ammeter modules.

## Identification labels

Interpact INS40 to 160 switch-disconnectors may receive Telemecanique prefabricated labels, catalogue number AB1- (eight characters). Interpact INS250 to 630 and INV100 to 630 switch-disconnectors are supplied as standard with a clip-on label for handwritten indications.

These devices also come with a nameplate into which a label can be inserted.

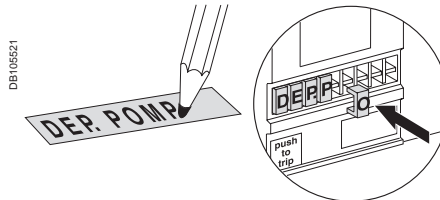

## Individual enclosures

Interpact INS and INV switch-disconnectors equipped with a front handle may be installed in individual enclosures.

All fixed, front connections are possible, except right-angle and edgewise terminal extensions. Spreaders may be installed in the enclosures intended for Interpact INS250 to 630 and INV100 to 630 switch-disconnectors.

### Heavy-duty metal individual enclosure for Interpact INS (IP55, IK08)

- metal enclosure
- door with keylock and cut-out for switch-disconnector rotary handle
- extended rotary front handle
- device mounting plate
- removable plate (without holes) for cable entry through bottom.

### Heavy-duty insulating individual enclosure for Interpact INS and INV (IP55, IK08)

- thermoplastic enclosure
- transparent cover, screwed, lead sealable, with cut-out for switch-disconnector rotary handle
- extended rotary front handle
- device mounting plate
- removable plates (without holes) for cable entry through bottom and/or top.

## Dimensions

Metal enclosures	H x W x D
Interpact INS40 to 160	350 x 350 x 260
Interpact INS250	450 x 350 x 260
Interpact INV100 to 250	
Interpact INS320 to 630	650 x 350 x 260
Interpact INV320 to 630	

Insulating enclosures	H x W x D
Interpact INS40 to 160	180 x 270 x 185
Interpact INS250	360 x 270 x 235
Interpact INV100 to 250	
Interpact INS320 to 630	720 x 360 x 235
Interpact INV320 to 630	



6227EB-35

## schneider-electric.com

This international site allows you to access all the Schneider Electric products in just 2 clicks via comprehensive range data-sheets, with direct links to:

- complete library: technical documents, catalogs, FAQs, brochures...
- selection guides from the e-catalog.
- product discovery sites and their Flash animations.

You will also find illustrated overviews, news to which you can subscribe, the list of country contacts...



## CAD software and tools

The CAD software and tools enhance productivity and safety. They help you create your installations by simplifying product choice through easy browsing in the Schneider Electric offers.

Last but not least, they optimise use of our products while also complying with standards and proper procedures.



<i>Presentation</i>	2
<i>Functions and characteristics</i>	A-1
<b>Operating principle</b>	<b>B-2</b>
<b>Possible installation positions and mounting techniques</b>	<b>B-4</b>
<b>Implementation</b>	<b>B-5</b>
<b>Interpact INS40 to 80</b>	<b>B-6</b>
<b>Interpact INS100 to 160</b>	<b>B-7</b>
<b>Interpact INS250-100 to 250</b>	
<b>Interpact INV100 to 250</b>	
<b>Complete source-changeover assembly INS250-100 to 250</b>	<b>B-8</b>
<b>Interpact INS320 to 630</b>	
<b>Interpact INV320 to 630</b>	
<b>Complete source-changeover assembly INS320 to 630</b>	<b>B-12</b>
<b>Interpact INS630b to 1600</b>	
<b>Interpact INV630b to 1600</b>	<b>B-16</b>
<b>Interpact INS2000 to 2500</b>	
<b>Interpact INV2000 to 2500</b>	<b>B-20</b>
<b>Use at high temperatures</b>	<b>B-22</b>
<i>Dimensions and connection</i>	C-1
<i>Additional characteristics</i>	D-1
<i>Catalogue numbers</i>	E-1

## INS40 to 250 - INV100 to 250

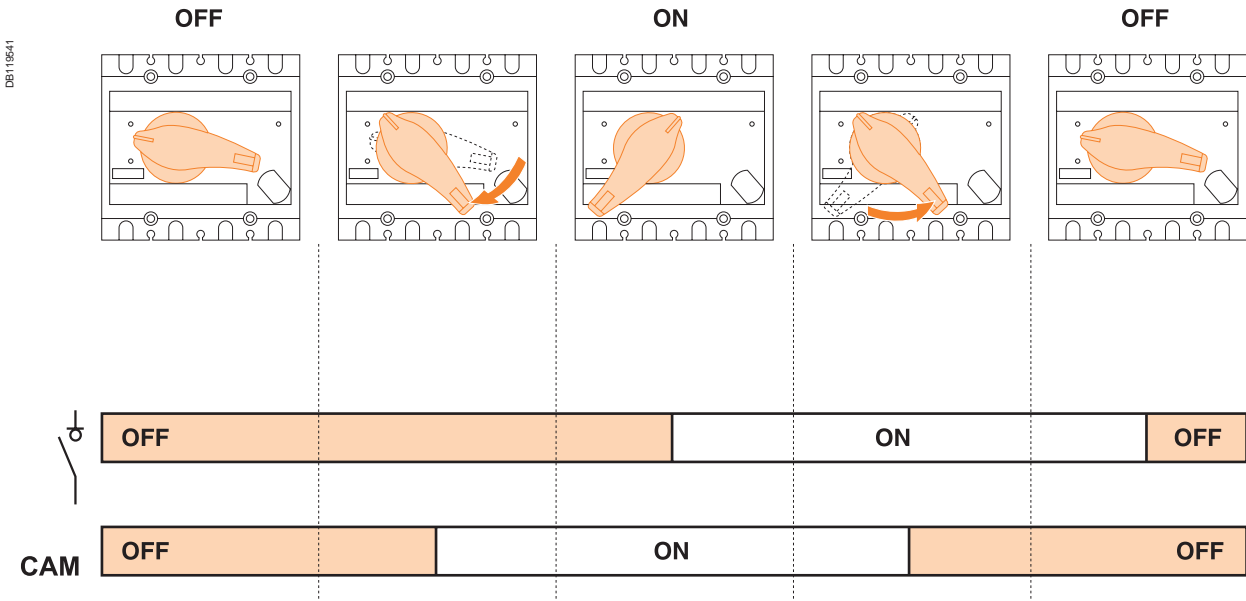

## INS320 to 630 - INV320 to 630

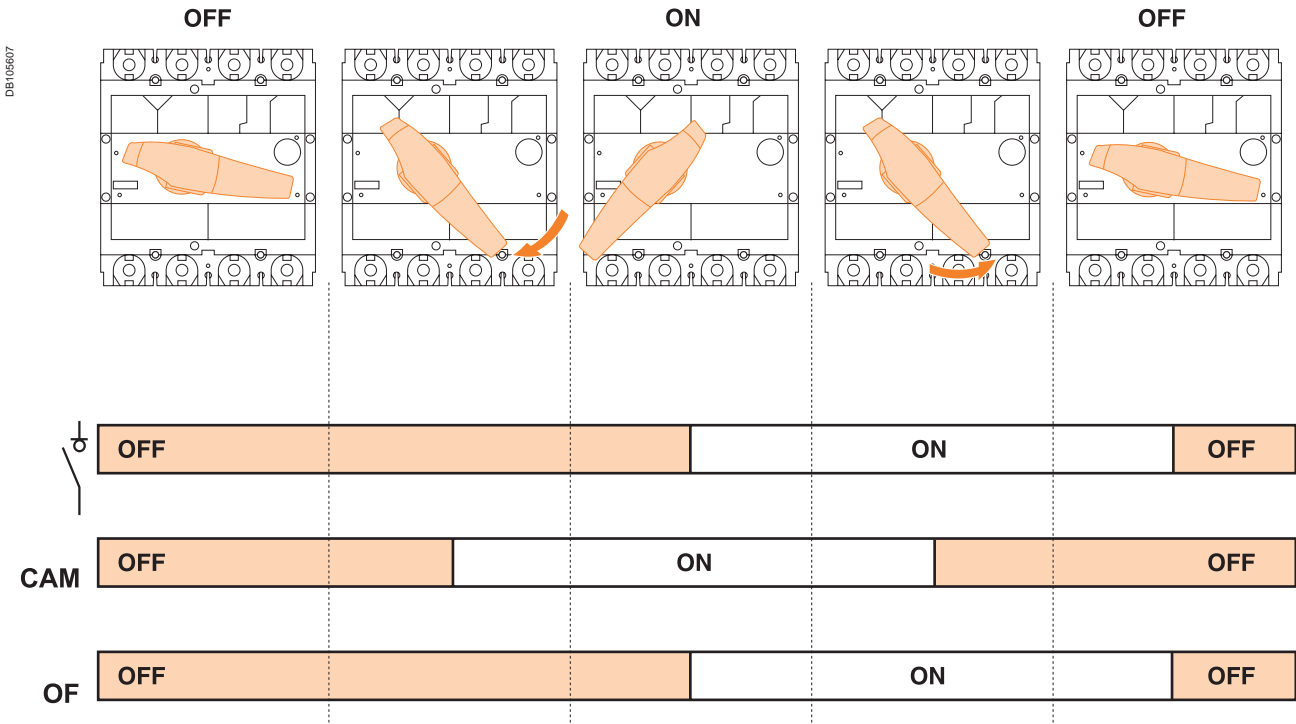



## INS630b to 2500 - INV630b to 2500

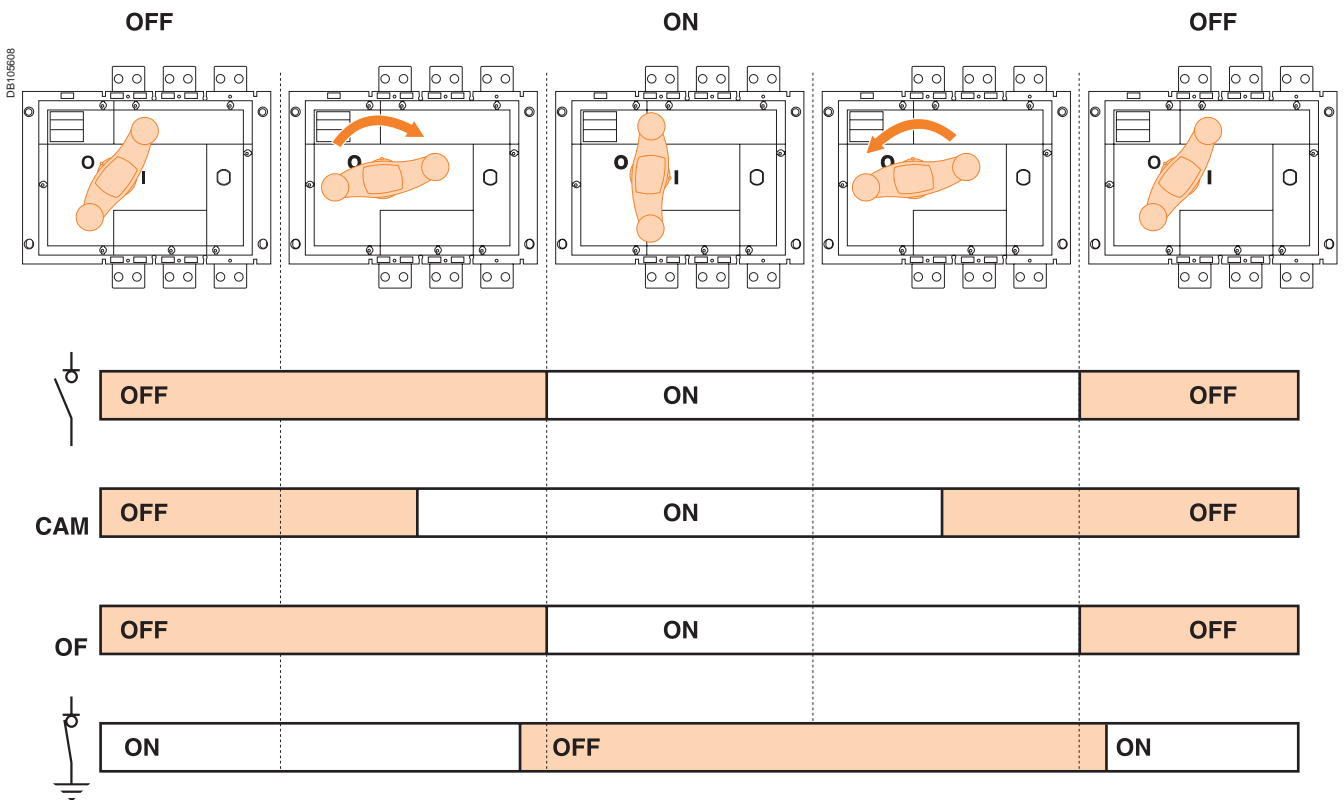

# Possible installation positions and mounting techniques

## Possible installation positions

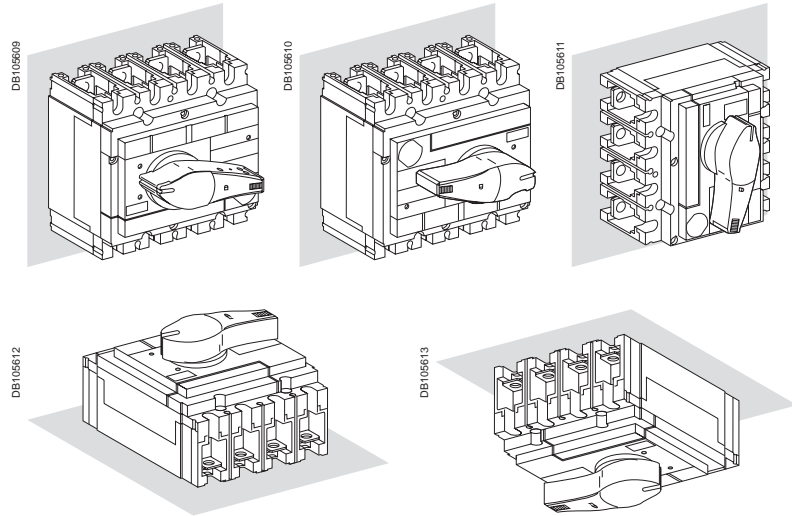

## Possible mounting INS40 to 160

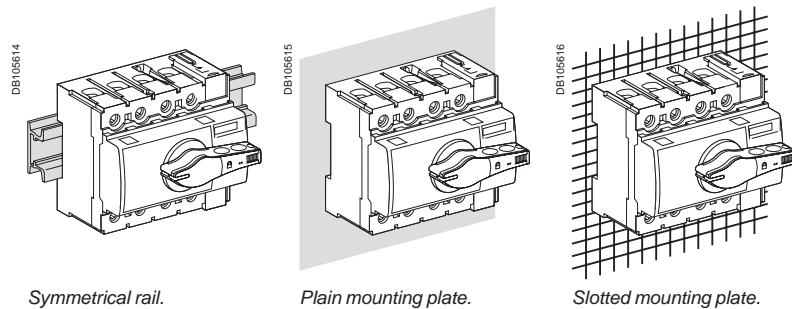

*Symmetrical rail.*

*Plain mounting plate.*

*Slotted mounting plate.*

## INS250-100 to 630 - INV100 to 630

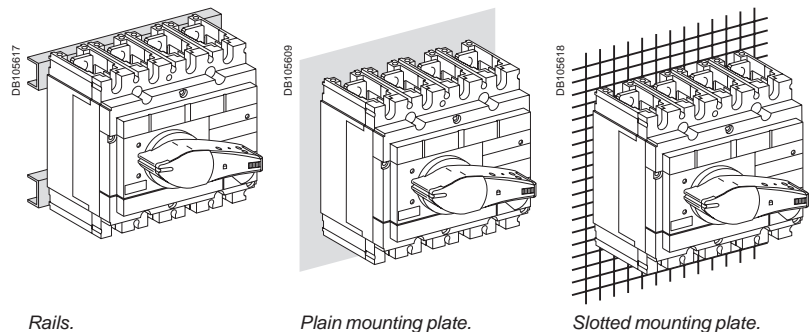

*Rails.*

*Plain mounting plate.*

*Slotted mounting plate.*

## INS/INV630b to 2500

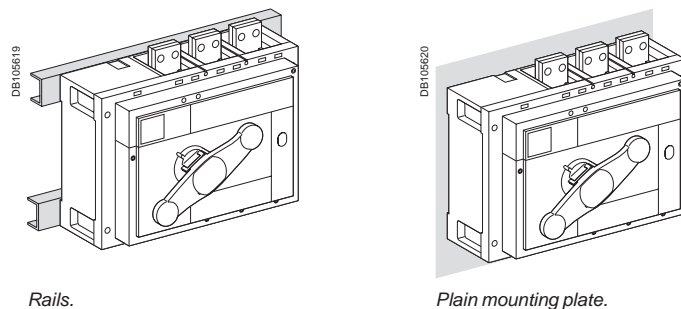

*Rails.*

*Plain mounting plate.*

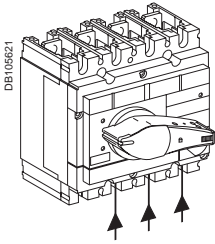

### Reverse supply

Interpact switch-disconnectors may be supplied indifferently via the top or bottom terminals, without any reduction in performance.

### Neutral pole position

On Merlin Gerin switch-disconnectors, the neutral pole is traditionally located on the left-hand side. On the INS and INV ranges, the four poles are identical and the neutral pole can therefore be located on the right-hand side simply by adding an appropriate label.

### Conductor materials and electrodynamic forces

Interpact switch-disconnectors may be connected using either bare copper, tinned copper or tinned aluminium conductors (flexible or rigid bars, cables).

In the event of a short-circuit, thermal and electrodynamic forces are exerted on the conductors. The conductors must therefore be adequately sized and suitably supported.

Note that the terminals of electrical devices (switch-disconnectors, contactors, circuit breakers, etc.) should not be considered to contribute to the support of the conductors.

### Cables ties and flexible bars

The table below indicates the maximum distances between cable ties depending on the prospective short-circuit current.

Care must be taken not to exceed a distance of 400 mm between ties mechanically secured to the switchboard frame.

Type of tie	"Panduit" type Width: 4.5 mm Max. load: 22 kg Colour: white					"Sarel" type Width: 9 mm Max. load: 90 kg Colour: black		
	200	100	50	350	200	100	70	50 (double ties)
Max. distance between ties (mm)								
Short-circuit current (kA rms)	10	15	20	20	27	35	45	100

**Note:** for cables  $\geq 50 \text{ mm}^2$ , 9 mm wide ties must be used.

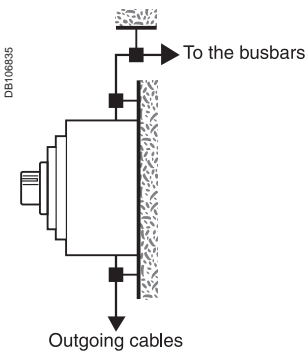

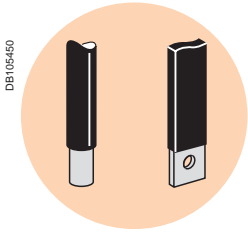

DBI105450

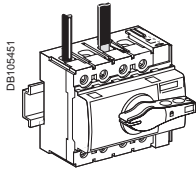

DBI105451

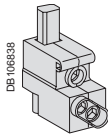

DBI106838

Distribution connector.

### Front connection of bare copper and aluminium cables

Interpact INS40 to INS80 switch-disconnectors are equipped as standard with connectors for bare copper or aluminium cables (1.5 to 50 mm<sup>2</sup> rigid cables, 1.5 to 35 mm<sup>2</sup> flexible cables)

#### Distribution connector

This connector screws directly into the switch-disconnector terminals for connection of three cables of the following types:

- 1 to 10 mm<sup>2</sup> flexible cables <sup>(1)</sup>
- 1.5 to 16 mm<sup>2</sup> rigid cables.

#### Pole pitch

18 mm

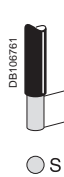

DBI106761



<sup>(1)</sup> Connection of 1.5 to 4 mm<sup>2</sup> flexible cables requires crimped or auto-crimping ferrules.

		Standard device	With distribution connector
Bars	e (mm)	≤ 15	-
	L (mm)	13	13
Lugs	L (mm)	≤ 10	≤ 10
	S (mm <sup>2</sup> )	1.5 to 50 rigid	1.5 to 16 rigid
	Cu / Al	1.5 to 35 flexible	1 to 10 flexible <sup>(1)</sup>
Torque	(Nm)	5	2

If 500 V ≤ U ≤ 690 V, long terminal shields are mandatory.

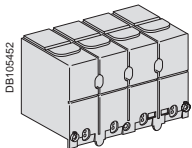

DBI105452

Terminal shields.

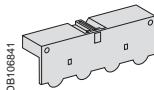

DBI106841

Terminal shrouds.

### Insulation of live parts

- With long terminal shields.
- With terminal shrouds.

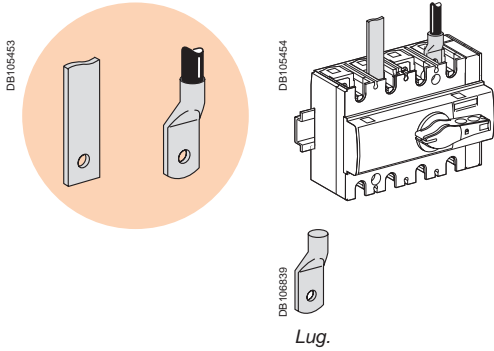

Lug.

## Front connection of insulated bars and cables with crimped lugs

Interpact INS100 to INS160 switch-disconnectors are equipped as standard with terminals comprising nuts with M6 screws for direct connection of insulated bars or cables with lugs.

### Lugs

The special lugs for copper cables may be used for cables with cross-sectional areas up to 95 mm<sup>2</sup>. Secure the lugs by hexagonal crimping or punching. Lugs are supplied with interphase-barrier and are compatible with the terminal shields.

Pole pitch		
30 mm		
Dimensions		
Bars	d (mm)	≤ 10
	e (mm)	2...6.4
	L (mm)	≤ 21
Lugs	L (mm)	15
	Ø (mm)	≥ 6.2
Torque	(Nm)	8

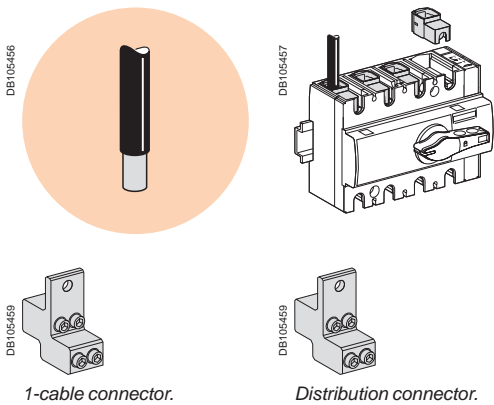
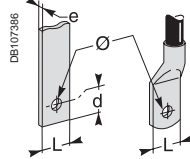

1-cable connector.

Distribution connector.

## Front connection of bare copper and aluminium cables

- 1-cable connectors snap directly onto the device terminals (1 to 10 mm<sup>2</sup> flexible cables <sup>(1)</sup>)
- Distribution connectors for 4 flexible cables (1.5 to 25 mm<sup>2</sup> rigid cables or 1.5 to 16 mm<sup>2</sup> flexible cables <sup>(1)</sup>) are screwed directly to the device terminals. These connectors are supplied with interphase-barrier (mandatory installation) which may be replaced by long terminal shields
- Distribloc distribution block supplied via tunnel terminals. Provides 12 screwless spring type and 1 screw type outgoing terminals.

		1-cable connector		Distribution connector
Lugs	L (mm)	15		15
	S (mm <sup>2</sup> )	1.5 to 35 rigid	50 to 95 rigid	1.5 to 25 rigid
	Cu / Al	1.5 to 35 flexible <sup>(1)</sup>	50 to 95 flexible	1.5 to 16 flexible <sup>(1)</sup>
Torque (Nm)		10	12	3
Distribloc				
Torque (Nm)		Supply: 5 Nm Distribution: 3 Nm		

<sup>(1)</sup> Connection of 1.5 to 4 mm<sup>2</sup> flexible cables requires crimped or auto-crimping ferrules.

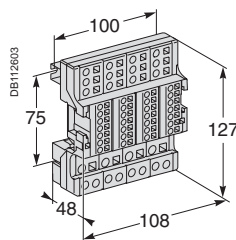

Distribloc 125 and 160 A.

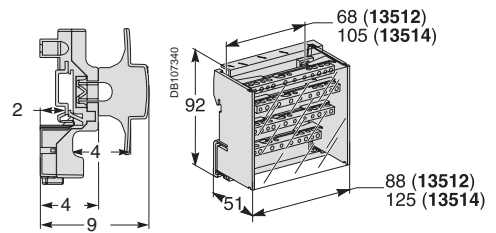

Multi-stage distribution block.

If 500 V ≤ U ≤ 690 V, interphase-barrier or long terminal shields are mandatory.

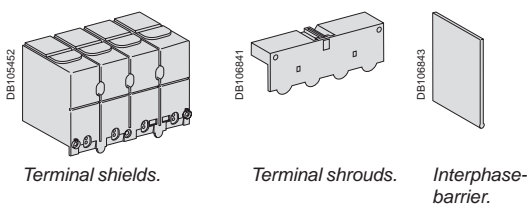

Terminal shields.

Terminal shrouds.

Interphase-barrier.

## Insulation of live parts

- With long terminal shields.
- With terminal shrouds.
- Interphase-barrier:
  - distribution blocks, lugs, right-angle/straight/edgewise terminal extensions and spreaders are supplied with interphase-barrier
  - interphase-barrier may be positioned horizontally or vertically
  - they may be replaced by long terminal shields.

# Interpact INS250-100 to 250 Interpact INV100 to 250 Complete source-changeover assembly INS250-100 to 250

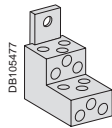
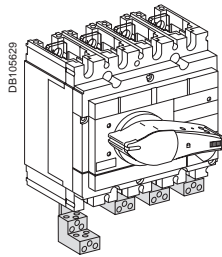
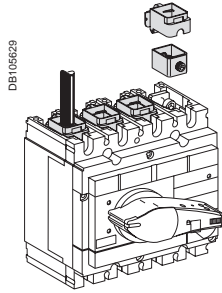
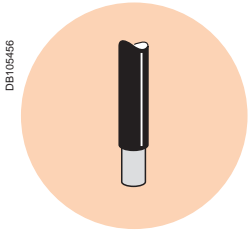

1-cable connector.

Distribution connector.

## Front connection of bare copper and aluminium cables

Bare-cable connectors for Interpact INS/INV switch-disconnectors may be used for both copper and aluminium cables.

### 1-cable connectors

The connectors snap directly on to the device terminals or clip onto right-angle and straight terminal extensions as well as spreaders. These connectors are supplied with interphase-barrier.

Material: steel I ≤ 160 A and tinned aluminium I ≤ 250 A.



### 6-cable distribution connectors

These connectors are screwed directly to device terminals. These connectors are supplied with interphase-barrier (mandatory installation) which may be replaced by long terminal shields. Each connector can receive six cables with cross-sectional areas ranging from 1.5 to 35 mm<sup>2</sup> each.

Material: tinned aluminium.

### Polybloc distribution blocks, for 6 or 9 rigid or flexible cables

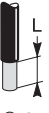
The Polybloc connects directly to the device terminals and is used to connect up to six or nine flexible or rigid cables with cross-sectional areas not exceeding 10 mm<sup>2</sup>, to each pole. Connection is made to spring terminals without screws.

	1-cable connector	Steel ≤ 160 A	Aluminium ≤ 250 A	
 L S	L (mm)	20	20	
	S (mm <sup>2</sup> ) Cu / Al	1.5...95 <sup>(1)</sup>	25...50	70...95 120...185
	Torque (Nm)	12	20	26 26
<b>Distribution connector, 6 cables Cu or Al</b>				
 L S	L (mm)	15 or 30		
	S (mm <sup>2</sup> ) Cu / Al	1.5...6 <sup>(1)</sup>	8...35	
	Torque (Nm)	4	6	
<b>Polybloc distribution block, 6 or 9 cables</b>				
	L (mm)	12		
	S (mm <sup>2</sup> ) Cu / Al	1.5...10		

<sup>(1)</sup> Connection of 1.5 to 4 mm<sup>2</sup> flexible cables requires crimped or auto-crimping ferrules.

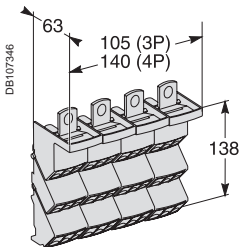

Polybloc 250 A distribution block.

## Dimensions

### 1-cable connector

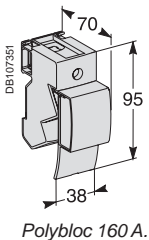
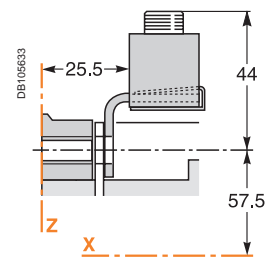
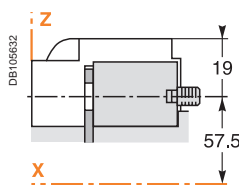

Polybloc 160 A.

### Distribution connector, 6 cables

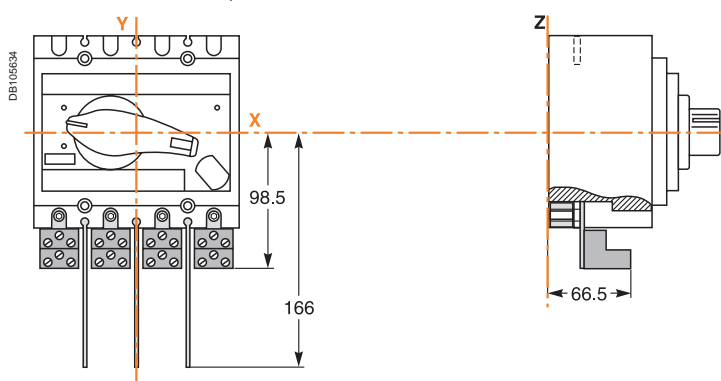

# Interpact INS250-100 to 250 Interpact INV100 to 250 Complete source-changeover assembly INS250-100 to 250

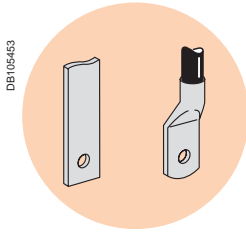

DB105453

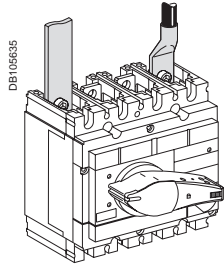

DB105635

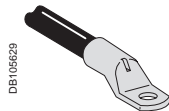

DB105629

Small lugs for copper cables.

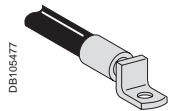

DB105477

Small lugs for aluminium cables.

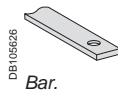

DB105626

Bar.

## Front connection of insulated bars and cables with crimped lugs

Interpact INS250-100 to INS250 and INV100 to 250 switch-disconnectors are equipped as standard with terminals receiving snap-in nuts and M8 screws for direct connection of insulated bars or cables with lugs.

### Lugs

- The small lugs for copper cables may be used for cables with the following cross-sectional areas 120, 150 or 185 mm<sup>2</sup> (secure the lugs by hexagonal crimping or punching).
- The small lugs for aluminium cables may be used for cables with the following cross-sectional areas 150 or 185 mm<sup>2</sup> (secure the lugs by hexagonal crimping).

### Pole pitch

35 mm

### Dimensions

	Bars	d (mm)	≤ 10
		e (mm)	≤ 6
		L (mm)	≤ 25
		Ø (mm)	≥ 10
	Lugs	L (mm)	≤ 25
		Ø (mm)	≥ 10
	Torque	(Nm)	15

### Dimensions

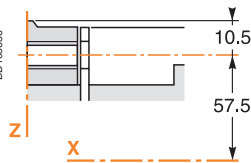

If  $500\text{ V} \leq U \leq 690\text{ V}$ , interphase-barrier or short or long terminal shields are mandatory.

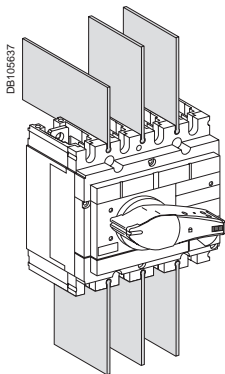

DB105637

Interphase-barrier.

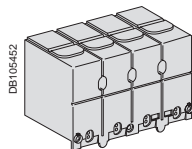

DB105452

Terminal shields.

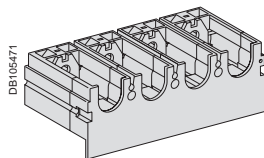

DB105471

One-piece spreader.

## Insulation of live parts

- With short or long terminal shields.
- Interphase-barrier:
  - distribution blocks, lugs, right-angle/straight/edgewise terminal extensions and spreaders are supplied with interphase-barrier
  - interphase-barrier may be positioned horizontally or vertically
  - they may be replaced by long terminal shields.
- One-piece spreader: the one-piece spreader increases the pitch to correspond to that of the upstream device and provides protection against direct contact (see page A-45).

# Interpact INS250-100 to 250 Interpact INV100 to 250 Complete source-changeover assembly INS250-100 to 250

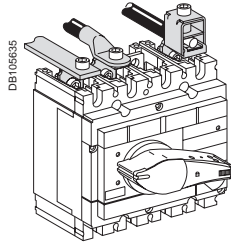
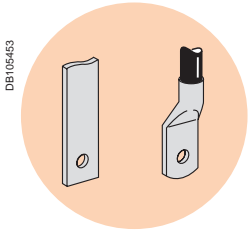

## Front connection with accessories

**Straight terminal extensions**  
Material: tinned copper.

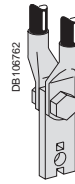
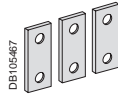

**Right-angle extensions**  
Material: tinned copper.

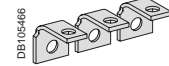

Connection of two cables with lugs.

Insulation stripping lengths and tightening torques for cables, bare bars and cables with lugs are identical to those for direct connection to devices.

**Spreader**  
Material: tinned copper.

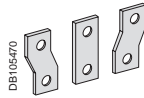

Separate parts.

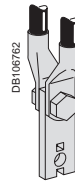

Connection of two cables with lugs.

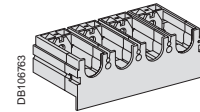

One-piece spreader.

## Pole pitch

45 mm

## Dimensions

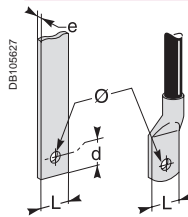

Bars	d (mm)	≤ 10
	e (mm)	≤ 6
	L (mm)	≤ 25
Lugs	Ø (mm)	8.5
	L (mm)	≤ 25
Torque	Ø (mm)	8.5
	(Nm)	15 <sup>(1)</sup>

(1) Tightening torque for spreader.

Spreaders, straight terminal extensions and right-angle terminal extensions are supplied with interphase-barrier.

## Dimensions

Spreader and straight terminal extensions

Right-angle terminal extensions

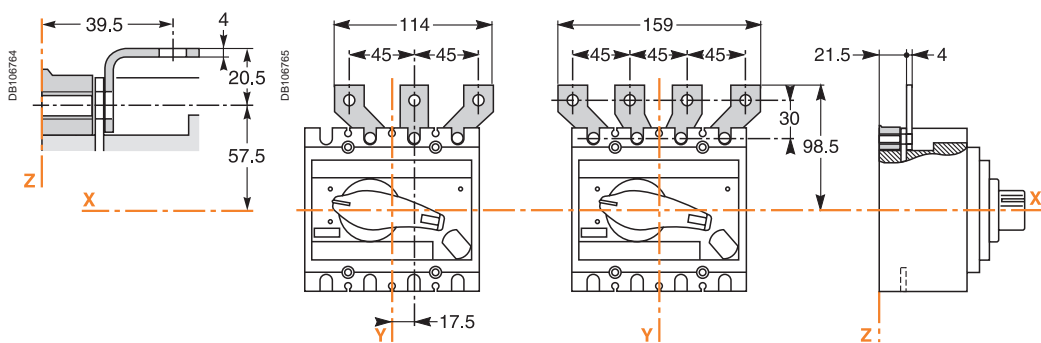

One-piece spreader 3P/4P

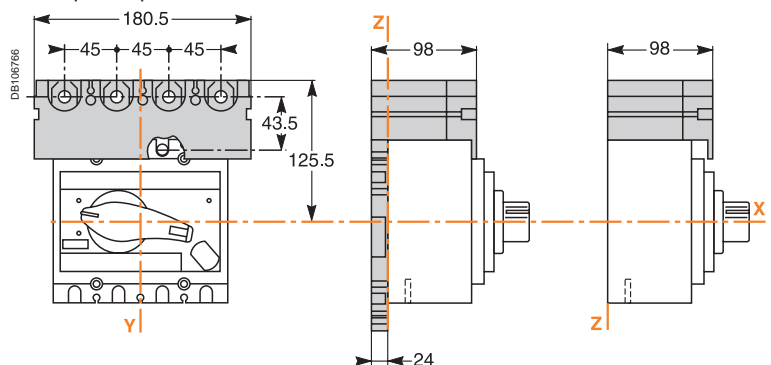



# Interpact INS250-100 to 250 Interpact INV100 to 250 Complete source-changeover assembly INS250-100 to 250

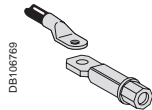
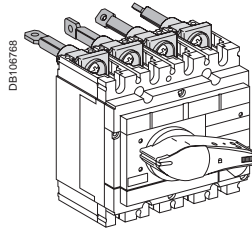
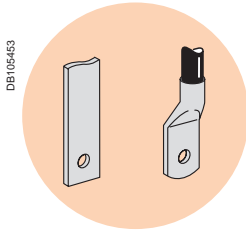

Connection of bars or cables with lugs.

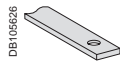

Bar.

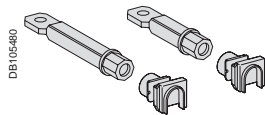

Two lengths.

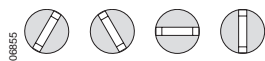

Four positions.

## Rear connection

The rear connections are simply fitted to the device connection terminals. All combinations of rear connection lengths and positions are possible on a given switch-disconnector. The switch-disconnector is mounted on a backplate. For the connection of cables without lugs, the 1-cable connectors for Interpact INS100-250 to INS250 and INV100 to 250 may be simply clipped onto the rear connections.

### Bars or cables with crimped lugs

Interpact INS250-100 to INS250 and INV100 to 250 switch-disconnectors may be equipped with long or short rear connections, or a mix of the two. The connections may be positioned flat, on edge or at 45° angles, or any combination thereof. Material of rear connections: tinned copper.

### Pole pitch

35 mm

### Dimensions

Bars	d (mm)	≤ 10
	e (mm)	≤ 6
	L (mm)	≤ 25
	Ø (mm)	≥ 8
Lugs	L (mm)	≤ 25
	Ø (mm)	≥ 8
Torque	(Nm)	5 <sup>(1)</sup>

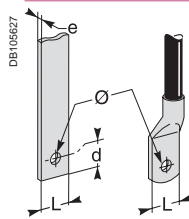

(1) Tightening torque for rear connections.

## Dimensions

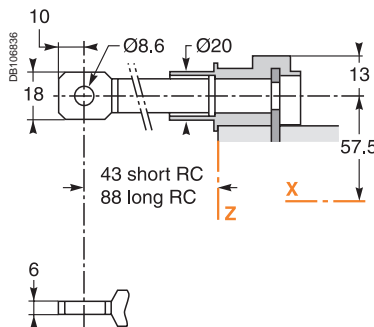

## Bare cables (copper or aluminium)

The rear connections may be equipped with 1-cable connectors secured by clips.

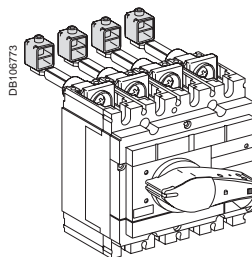

	1-cable connector	Steel ≤ 160 A	Aluminium ≤ 250 A
L (mm)		20	20
S (mm <sup>2</sup> ) Cu / Al		1.5...95 <sup>(1)</sup>	120...185
Torque (Nm)		12	26
Distribution connector, 6 cables Cu or Al			
L (mm)		15 or 30	
S (mm <sup>2</sup> ) Cu / Al		1.5...6 <sup>(1)</sup>	8...35
Torque (Nm)		4	6

(1) Connection of 1.5 to 4 mm<sup>2</sup> flexible cables requires crimped or auto-crimping ferrules.

Insulation stripping lengths and tightening torques for cables, bare bars and cables with lugs are identical to those for direct connection to devices.

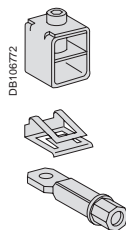

Rear connection with bar.

# Interpact INS320 to 630 Interpact INV320 to 630 Complete source-changeover assembly INS320 to 630

DB105456

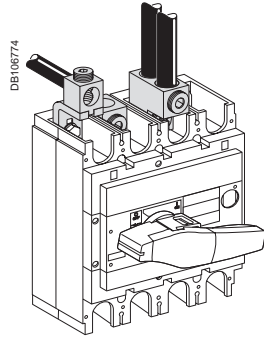
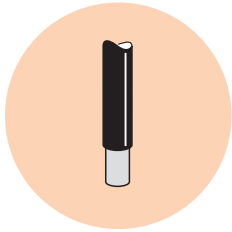

DB106774

## Front connection of bare copper and aluminium cables

Bare-cable connectors for Interpact INS/INV switch-disconnectors may be used for both copper and aluminium cables.

### 1-cable and 2-cable connectors

1-cable and 2-cable connectors, made of tinned aluminium for copper and aluminium cables, are screwed to the device terminals or to right-angle terminal extensions. These connectors are supplied with interphase-barrier.

	1-cable connector	2-cable connector
Torque (Nm)	31	31



DB105630

○ S

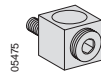

DB105475

1-cable connector.

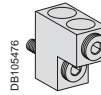

DB105476

2-cable connector.

## Dimensions

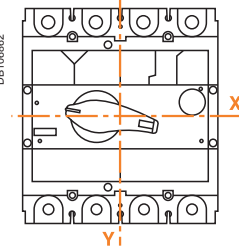

DB106862

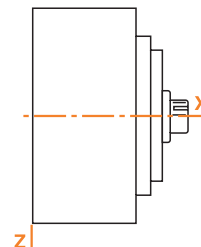

### 1-cable connector

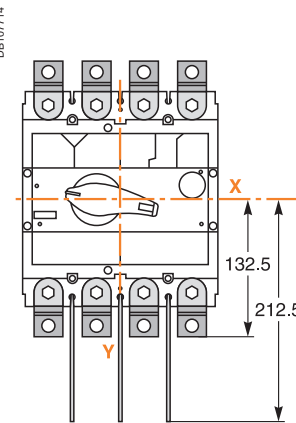

DB107714

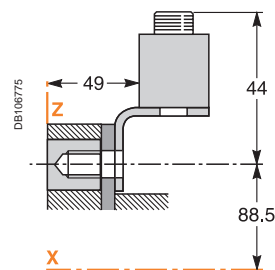

DB106775

### 2-cable connector

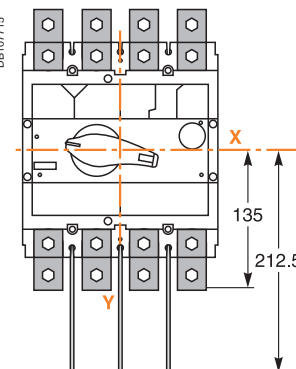

DB107715

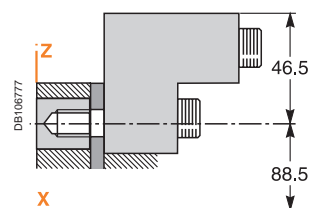

DB106777

# Interpact INS320 to 630 Interpact INV320 to 630 Complete source-changeover assembly INS320 to 630

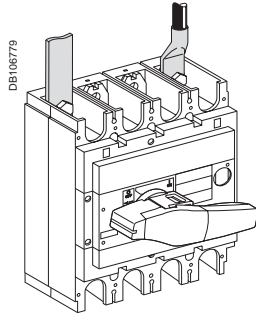
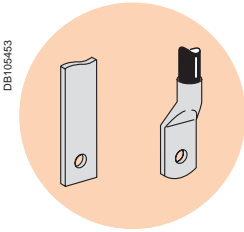

## Front connection of insulated bars and cables with crimped lugs

Interpact INS320 to 630 and INV320 to 630 switch-disconnectors are equipped as standard with terminals receiving snap-in nuts and M10 screws for direct connection of bars or cables with lugs.

### Lugs

- The small lugs for copper cables may be used for cables with the following cross-sectional areas 240 or 300 mm<sup>2</sup> (secure the lugs by hexagonal crimping or punching).
- The small lugs for aluminium cables may be used for cables with the following cross-sectional areas 240 or 300 mm<sup>2</sup> (secure the lugs by hexagonal crimping).

**Pole pitch**  
45 mm

### Dimensions

Bars	d (mm)	≤ 15
	e (mm)	3 ≤ e ≤ 10
	L (mm)	≤ 32
Lugs	Ø (mm)	≥ 10
	L (mm)	≤ 32
Torque	(Nm)	50

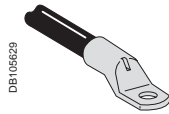

Small lugs for copper cables.

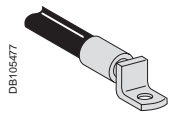

Small lugs for aluminium cables.

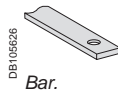

Bar.

### Dimensions

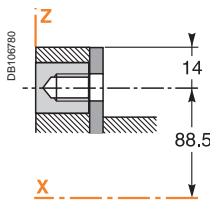

If  $500\text{ V} \leq U \leq 690\text{ V}$ , interphase-barrier or short or long terminal shields are mandatory.

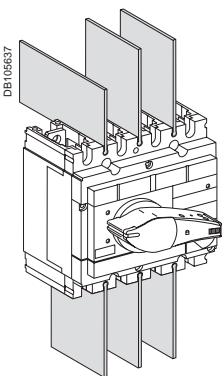

Interphase-barrier.

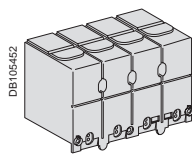

Terminal shields.

## Insulation of live parts

- With short or long terminal shields.
- Interphase-barrier:
  - distribution blocks, lugs, right-angle/straight/edgewise terminal extensions and spreaders are supplied with interphase-barrier
  - interphase-barrier may be positioned horizontally or vertically
  - they may be replaced by long terminal shields.

# Interpact INS320 to 630 Interpact INV320 to 630 Complete source-changeover assembly INS320 to 630

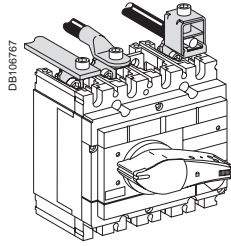
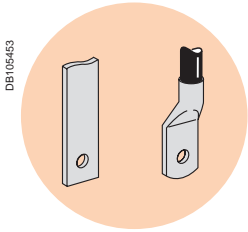

## Front connection with accessories

### Spreader

Material: tinned copper.

### Edgewise terminal extensions

Material: tinned copper.

### Right-angle extensions

Material: tinned copper.  
Installation on upstream terminals.

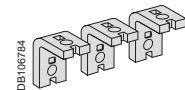
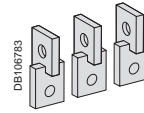
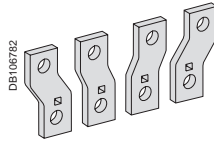

### Pole pitch

Without spreader	45 mm
With spreader	52.5 or 70 mm

### Dimensions

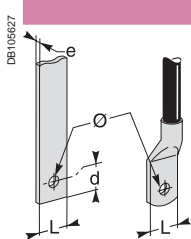

	With spreader	With edgewise terminal ext.
Bars	$d$ (mm) $\leq 15$	$\leq 15$
	$e$ (mm) $3 \leq e \leq 10$	$3 \leq e \leq 10$
	$L$ (mm) $\leq 32$	$\leq 32$
	$\varnothing$ (mm) $> 10.5$	$> 10.5$
Lugs	$L$ (mm) $\leq 32$	$\leq 32$
	$\varnothing$ (mm) 10.5	10.5
Torque	(Nm) 50 <sup>(1)</sup>	50 <sup>(1)</sup>

<sup>(1)</sup> Tightening torque for spreader.

Spreaders, straight terminal extensions and right-angle terminal extensions are supplied with interphase-barrier.

## Dimensions

### Edgewise terminal extensions

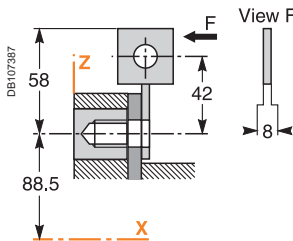

### Right-angle terminal extensions

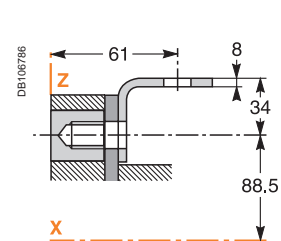

### Spreader

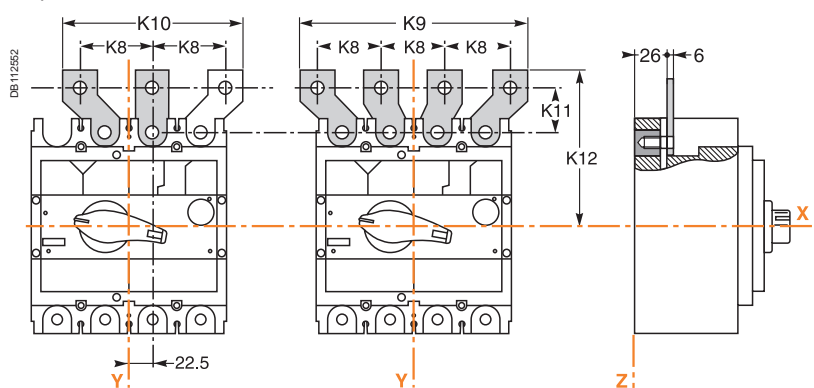

Type		K8	K9	K10	K11	K12
Spreader	Width in mod. of 52.5 mm	52.5	187.5	135	39	142.5
	Width in mod. of 70 mm	70	240	170	52.5	156

# Interpact INS320 to 630 Interpact INV320 to 630 Complete source-changeover assembly INS320 to 630

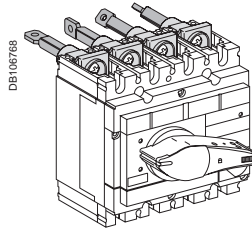
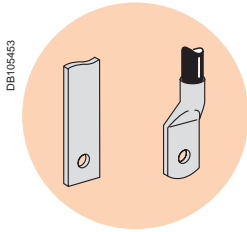

## Rear connection

The rear connections are simply fitted to the device connection terminals. All combinations of rear connection lengths and positions are possible on a given switch-disconnector. The switch-disconnector is mounted on a backplate.

### Bars or cables with crimped lugs

Interpact INS320 to 630 and INV320 to 630 switch-disconnectors may be equipped with long or short rear connections, or a mix of the two. The connections may be positioned flat, on edge or at 45° angles, or any combination thereof. Material of rear connections: tinned copper.

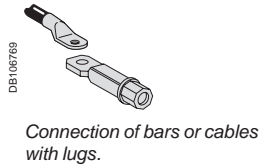

Connection of bars or cables with lugs.

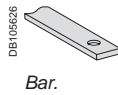

Bar.

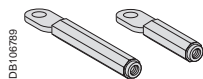

Two lengths.

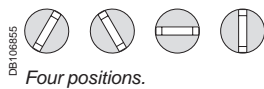

Four positions.

## Dimensions

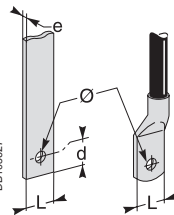

Bars	d (mm)	≤ 15
	e (mm)	3 ≤ e ≤ 10
	L (mm)	≤ 32
Lugs	L (mm)	≤ 32
	Ø (mm)	> 10.5
Torque	(Nm)	20 <sup>(1)</sup>

(1) Tightening torque for rear connections.

## Dimensions

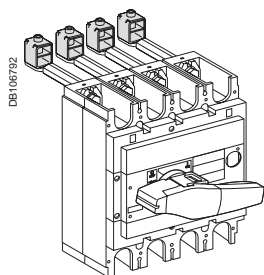
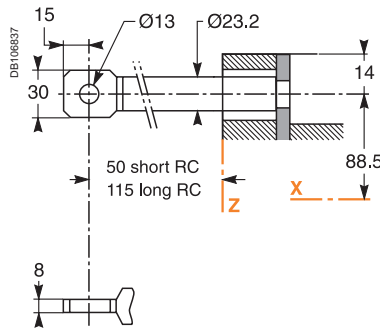

### Bare cables (copper or aluminium)

The rear connections may be equipped with 1-cable connectors secured by clips. Insulation stripping lengths and tightening torques for cables, bare bars and cables with lugs are identical to those for direct connection to devices.

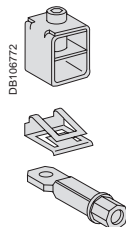

Rear connection with bar.

DB105483

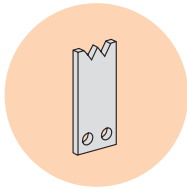

DB105487

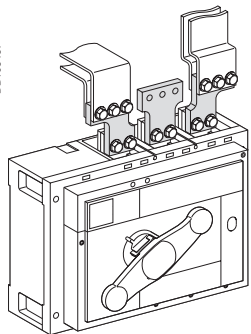

### Connections

There are many solutions to connect bars:

- vertical connection adapters to connect edgewise bars,
- spreaders with a 95 mm pole pitch to increase the clearance between bars.

### Spreaders

Spreaders increase the pole pitch of a switch-disconnector for greater clearance between the bars. They are not compatible with terminal shields.

DB105488

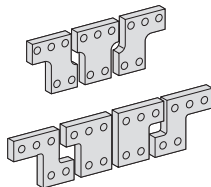

Spreaders.

DB105480

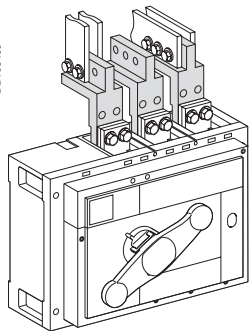

### Vertical connection adapters

For connection of edgewise bars.

DB105489

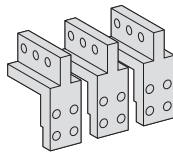

Vertical connection adapters.

DB105492

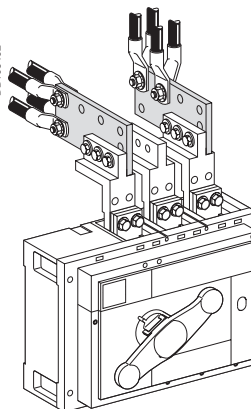

2-cable connector.

### Adapters for cables with crimped lugs

Cable-lug adapters are used in conjunction with vertical connection adapters.

They may be used to connect one to four cables ( $S \leq 300 \text{ mm}^2$ ) with crimped lugs. To ensure adequate mechanical strength, the cable-lug adapters must be secured together by spacers.

DB106703



Lugs for copper cables.

DB105491

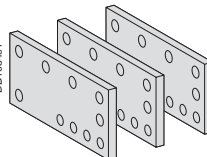

Adapters for cables with crimped lugs.

Pole pitch				
Without spreader		70 mm		
With spreader		95 mm		
Dimensions		With spreader	With vertical connection adapters	With cable lug adapters
Bars	d (mm)	12.5	$\leq 12.5$	-
	e (mm)	$3 \leq e \leq 10$	$3 \leq e \leq 10$	-
	L (mm)	$\leq 80$	$\leq 80$	-
	$\varnothing$ (mm)	12	$> 12$	-
Lugs	L (mm)	-	-	$\leq 40$
	$\varnothing$ (mm)	-	-	$\leq 12$
Torque	(Nm)	50 <sup>(1)</sup>	50	50 <sup>(1)</sup>

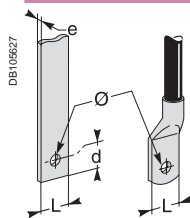

(1) Tightening torque for spreader.

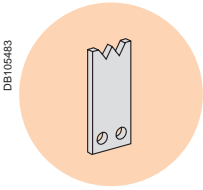

DBI105483

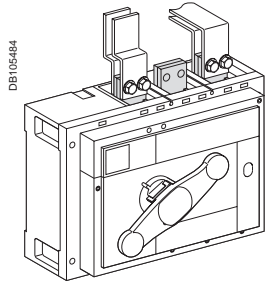

DBI105484

### Front connection of insulated bars

#### Connection of bars

Interpact switch-disconnectors are equipped with terminals for direct connection of bars.

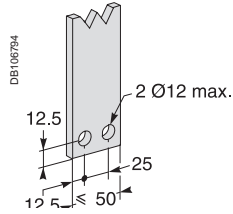

DBI106794

If  $500\text{ V} \leq U \leq 690\text{ V}$ , interphase-barrier or short or long terminal shields are mandatory.

### Insulation of live parts

- With terminal shields.
- Interphase-barrier:
  - interphase-barrier may be positioned horizontally or vertically,
  - they may be replaced by long terminal shields.

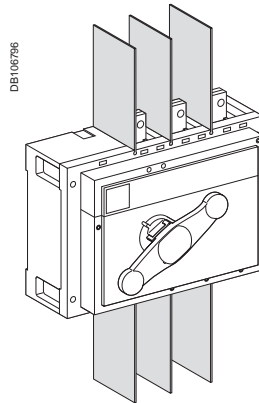

DBI106796

Interphase-barrier.

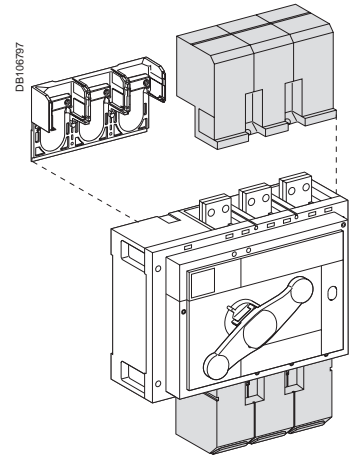

DBI106797

Terminal shield.

### Compatibility of terminal shields + base for connections

	Base	Terminal shields	Spreader	Interphase-barrier
Base	-	YES	YES	NO
Terminal shields	YES	-	NO	NO
Spreader	NO	NO	-	YES
Interphase-barrier	NO	NO	YES	-

## Dimensions

### Connection with spreaders

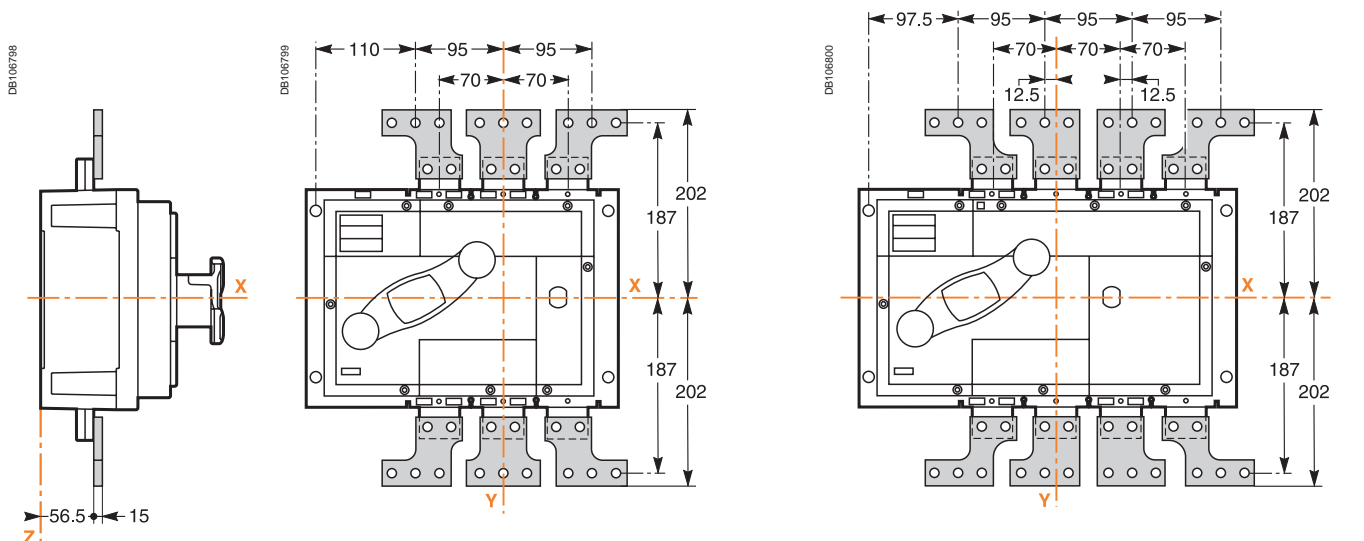

### Spreader details

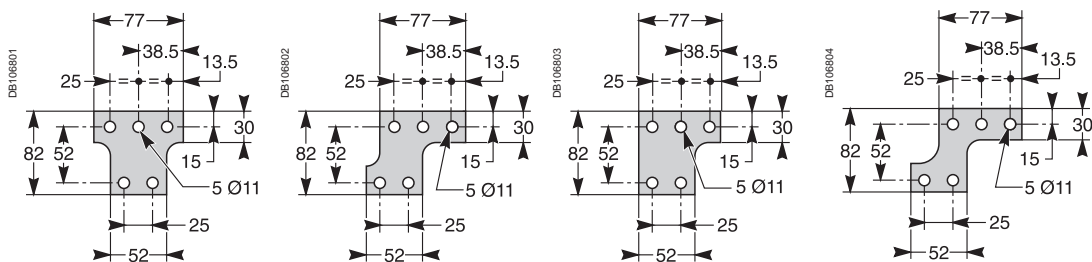

For 3P switch-disconnectors.

For 4P switch-disconnectors.

### Connection with vertical connection adapters

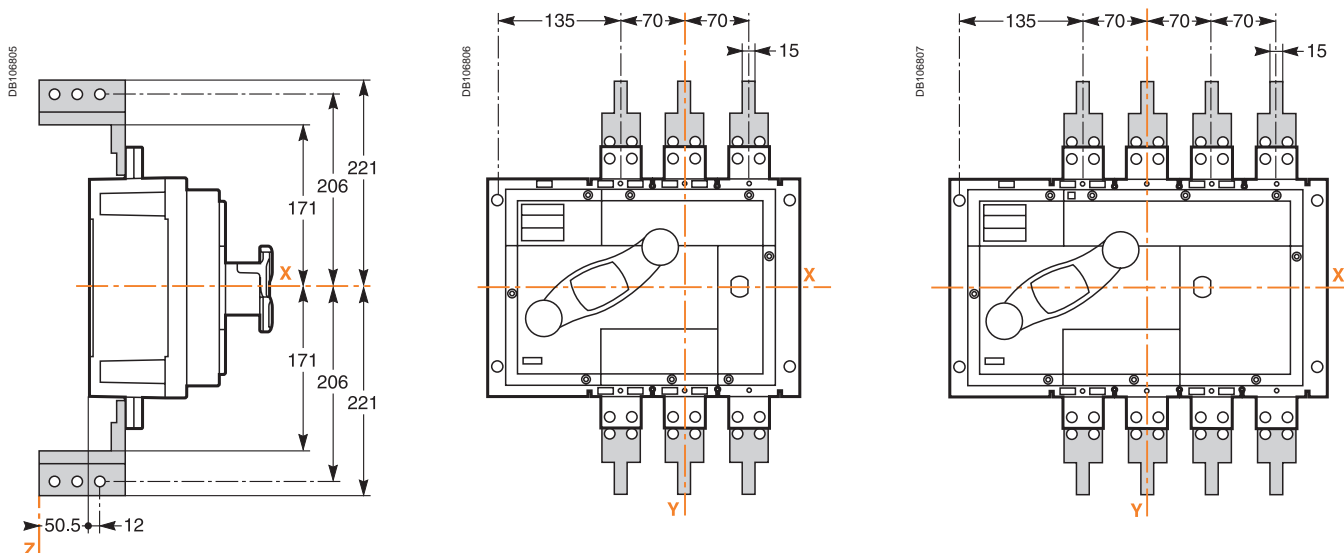

### Connector details

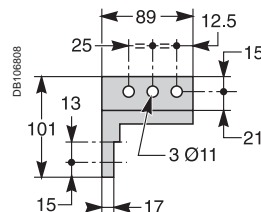

**Note:** lines X and Y indicate the axes of symmetry of the switch-disconnector.  
 Reference plane Z corresponds to the back of the switch-disconnector.  
 2 connection possibilities on vertical connection adapters (21 mm between centres).  
 Recommended connection screws: M10 class 8.8.  
 Tightening torque: 50 Nm with contact washer.



Connection with vertical connection adapters

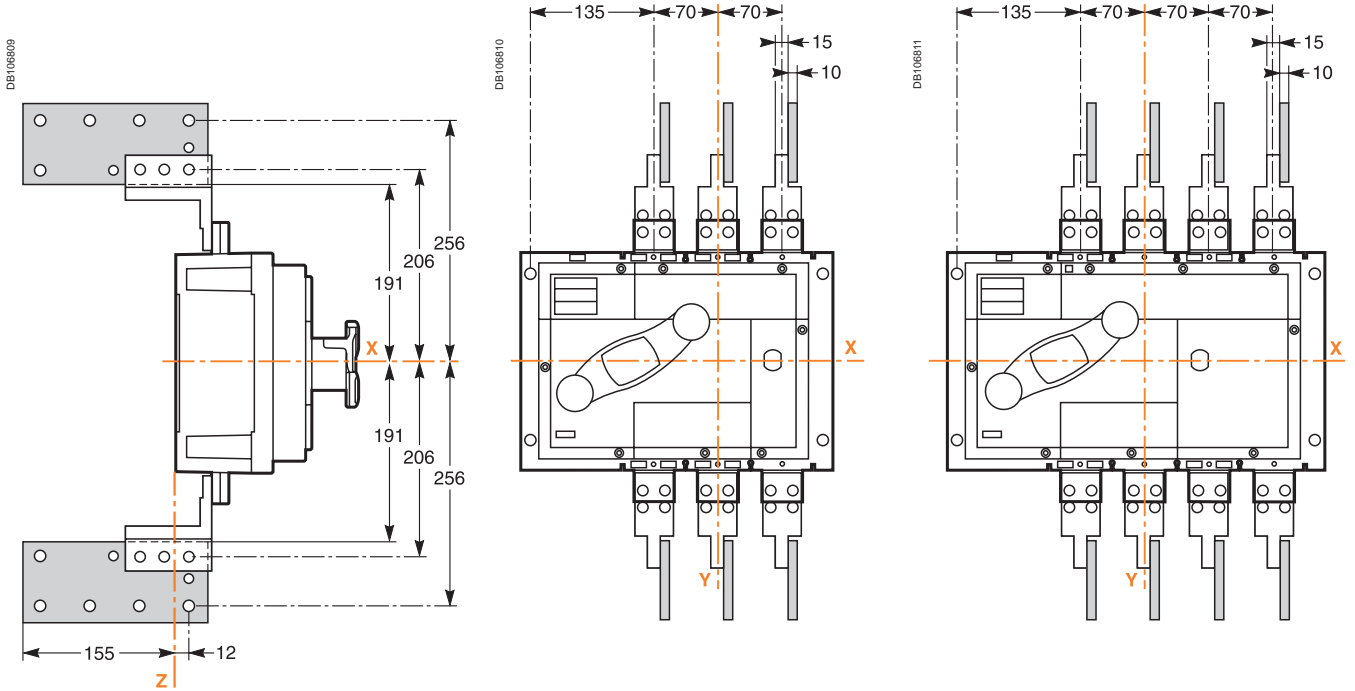

Cable lug adapter detail

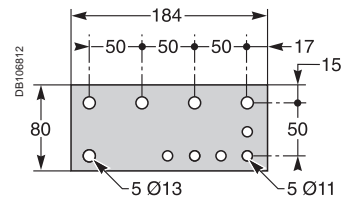

DB1065483

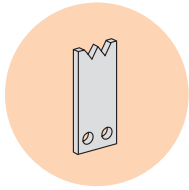

### Front connection of insulated bars

#### Connection of bars

Interpact switch-disconnectors are equipped with terminals for direct connection of bars.

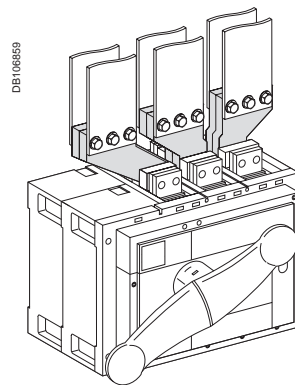
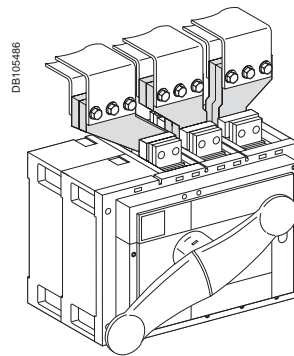
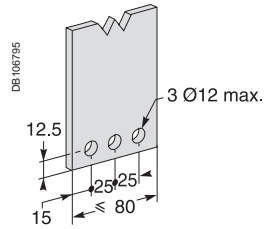

### Connector for connection of edgewise bars

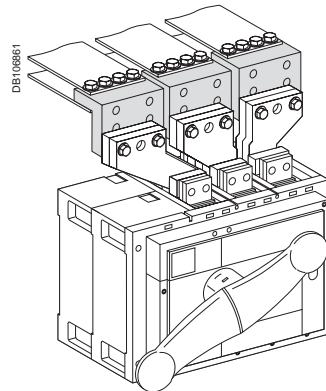
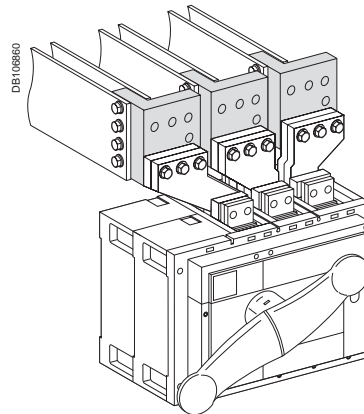

If  $500\text{ V} \leq U \leq 690\text{ V}$ , interphase-barrier are mandatory.

### Insulation of live parts

Interphase-barrier

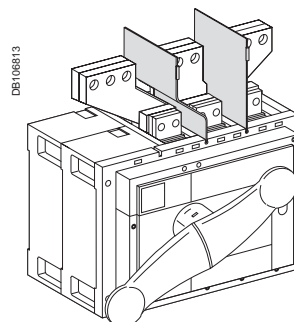

## Dimensions

### Connection with spreaders

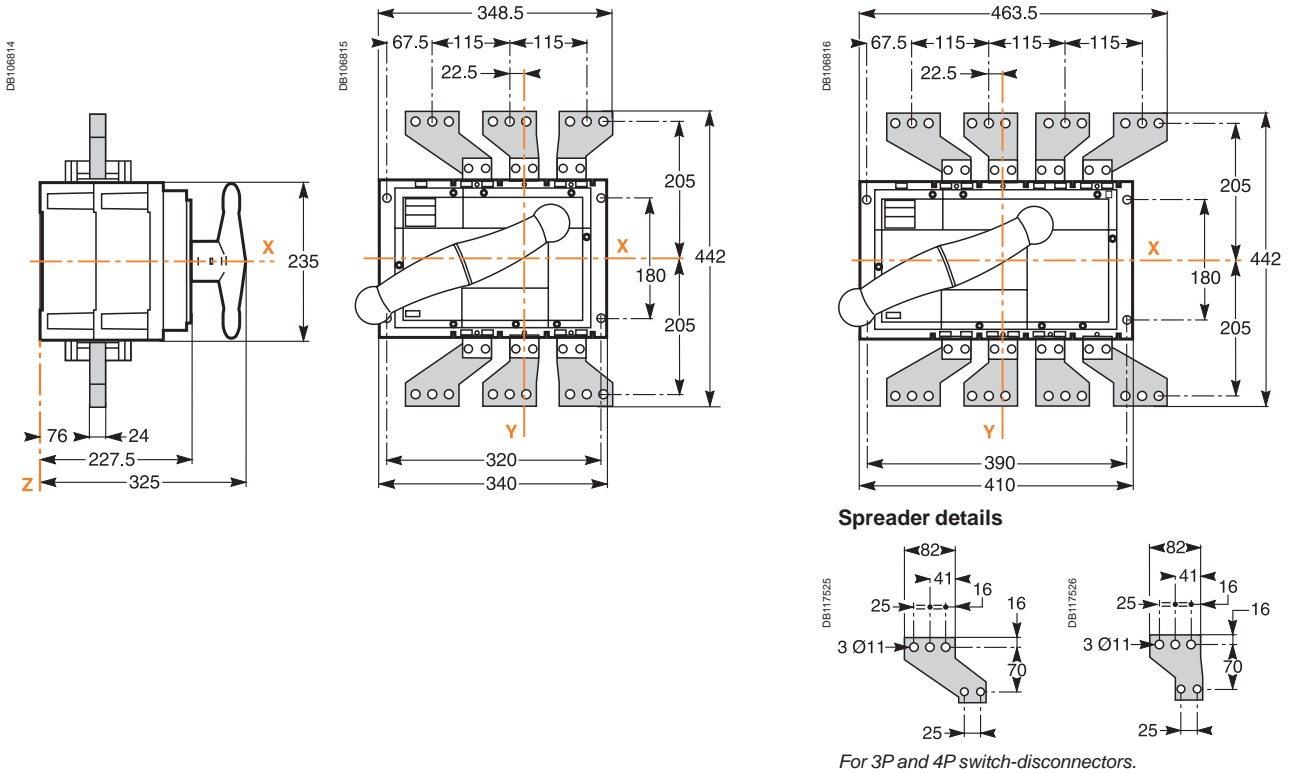

### Connection with spreaders

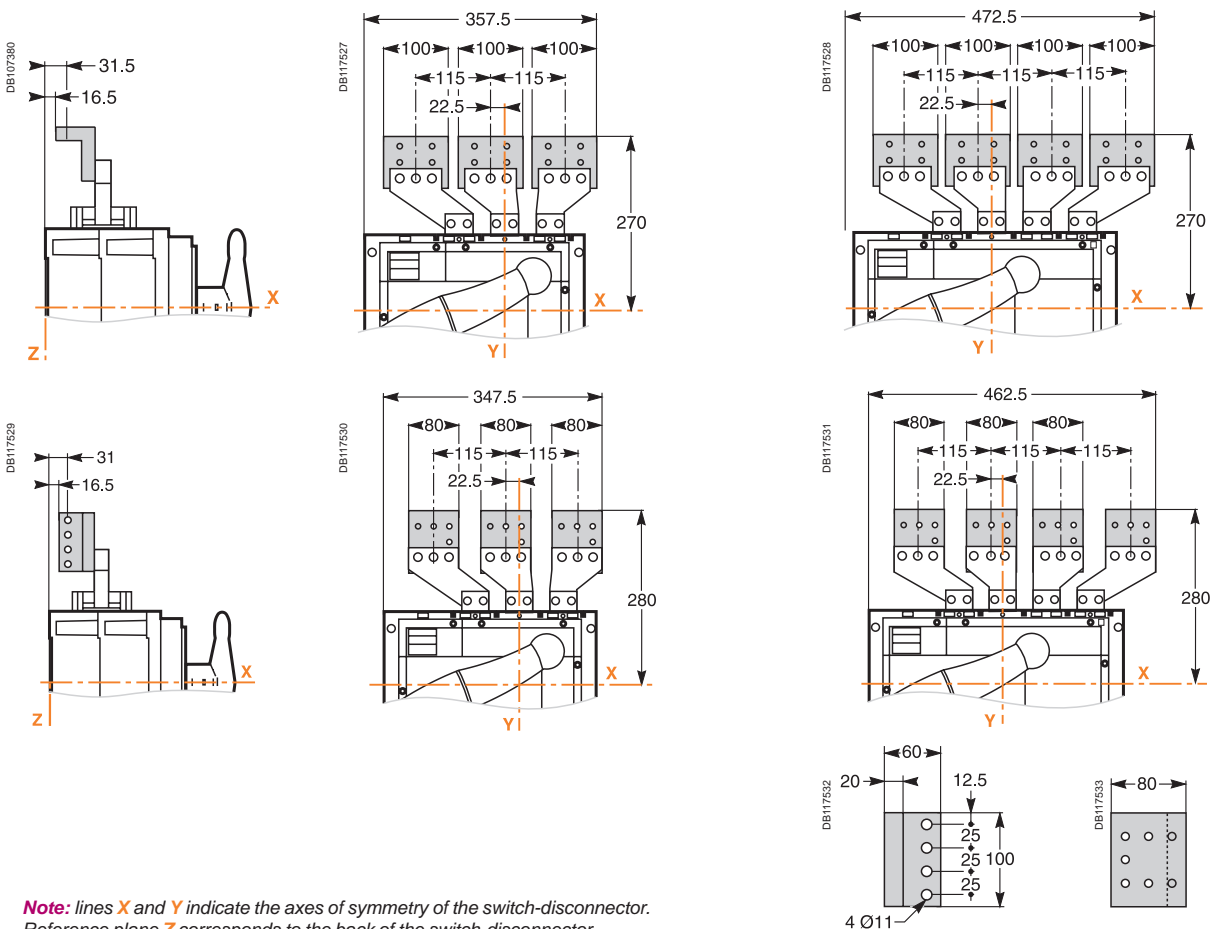

**Note:** lines X and Y indicate the axes of symmetry of the switch-disconnector. Reference plane Z corresponds to the back of the switch-disconnector.

Power dissipated and resistance per pole

<b>Interpact INS</b>	<b>40</b>	<b>63</b>	<b>80</b>	<b>100</b>	<b>125</b>	<b>160</b>			
Ra ing (A)	40	63	80	100	125	160			
Resistance per pole (mΩ)	0.3	0.3	0.3	0.2	0.2	0.2			
Power dissipated per pole (W)	0.5	1.2	1.9	2	3.1	5.1			
<b>Interpact INS/INV</b>	<b>100</b>	<b>160</b>	<b>200</b>	<b>250</b>	<b>320</b>	<b>400</b>	<b>500</b>	<b>630</b>	
Ra ing (A)	100	160	200	250	320	400	500	630	
Resistance per pole (mΩ)	0.15	0.15	0.15	0.15	0.06	0.06	0.06	0.06	
Power dissipated per pole (W)	1.5	4	6	9.5	6.1	9.6	15	24	
<b>Interpact INS/INV</b>	<b>800</b>	<b>1000</b>	<b>1250</b>	<b>1600</b>	<b>2000</b>	<b>2500</b>			
Ra ing (A)	800	1000	1250	1600	2000	2500			
Resistance per pole (mΩ)	0.024	0.024	0.024	0.024	0.012	0.012			
Power dissipated per pole (W)	16	24	38	62	48	75			

Temperature derating

<b>Interpact INS</b>	<b>40</b>	<b>63</b>	<b>80</b>	<b>100</b>	<b>125</b>	<b>160</b>			
<b>Front connection with bare-cable connectors or lugs</b>									
Thermal current Ith at	60 °C	40	63	80	100	125	160		
	65 °C	40	63	80	100	125	160		
	70 °C	40	63	80	100	125	150		
<b>Interpact INS/INV</b>	<b>100</b>	<b>160</b>	<b>200</b>	<b>250</b>	<b>320</b>	<b>400</b>	<b>500</b>	<b>630</b>	
<b>Front connection / rear connection</b>									
Thermal current Ith at	60 °C	100	160	200	250	320	400	500	630
	65 °C	100	160	200	250	320	400	500	590
	70 °C	100	160	200	250	320	400	500	550
<b>Front connection with right-angle terminal extension + bare-cable connectors</b>									
Thermal current Ith at	55 °C	100	160	200	250	320	400	500	630
	60 °C	100	160	200	250	320	400	500	590
	65 °C	100	160	200	250	320	400	500	550
	70 °C	100	160	200	240	320	400	500	510
<b>Front connection / rear connection with ammeter or CT module</b>									
Thermal current Ith at	40 °C	100	160	200	250	320	400	500	600
	50 °C	100	160	200	250	320	400	500	575
	55 °C	100	160	200	250	320	400	500	540
	60 °C	100	160	200	240	320	400	500	505
	65 °C	100	160	200	230	320	400	480	480
	70 °C	100	160	200	210	320	400	450	450

<b>Interpact INS/INV</b>	<b>630b</b>	<b>800 with or without term. shield</b>	<b>1000 with or without term. shield</b>	<b>1250 with term. shield</b>	<b>without term. shield</b>	<b>1600 with term. shield</b>	<b>without term. shield</b>	<b>2000 with term. shield</b>	<b>2500 without term. shield</b>	
<b>Direct connection by flat-facing bars</b> <sup>(1)</sup>										
Thermal current Ith at	40 °C	630	800	1000	1250	1250	1600	1600	2000	2500
	45 °C	630	800	1000	1250	1250	1570	1600	2000	2500
	50 °C	630	800	1000	1250	1250	1500	1550	2000	2500
	55 °C	630	800	1000	1250	1250	1420	1470	2000	2500
	60 °C	630	800	1000	1250	1250	1340	1390	2000	2500
	65 °C	630	800	1000	1250	1250	1250	1300	2000	2500
	70 °C	630	800	1000	1060	1210	1060	1210	2000	2400
<b>Connection by flat-facing bars via spreaders, without terminal shields</b> <sup>(2)</sup>										
Thermal current Ith at	40 °C	630	800	1000	1250	1600		-	-	
	45 °C	630	800	1000	1250	1600		-	-	
	50 °C	630	800	1000	1250	1580		-	-	
	55 °C	630	800	1000	1250	1500		-	-	
	60 °C	630	800	1000	1250	1420		-	-	
	65 °C	630	800	1000	1250	1330		-	-	
	70 °C	630	800	1000	1240	1240		-	-	
<b>Connection of edgewise bars via vertical connection adapters or cables via vertical connection adapters with cable-lug adapters</b>										
Thermal current Ith at	40 °C	630	800	1000	1250	1600	1600	-	-	
	45 °C	630	800	1000	1250	1600	1600	-	-	
	50 °C	630	800	1000	1250	1600	1600	-	-	
	55 °C	630	800	1000	1250	1600	1600	-	-	
	60 °C	630	800	1000	1250	1600	1600	-	-	
	65 °C	630	800	1000	1250	1520	1560	-	-	
	70 °C	630	800	1000	1250	1410	1450	-	-	

(1) INS/INV1600: 4 bars 50 x 5.

(2) INS/INV1600: 3 bars 80 x 5.

Note: thermal current Ith in Amps (QA).



## schneider-electric.com

This international site allows you to access all the Schneider Electric products in just 2 clicks via comprehensive range data-sheets, with direct links to:

- complete library: technical documents, catalogs, FAQs, brochures...

- selection guides from the e-catalog.

- product discovery sites and their Flash animations.

You will also find illustrated overviews, news to which you can subscribe, the list of country contacts...

## Training

Training allows you to acquire the Schneider Electric expertise (installation design, work with power on, etc.) for increased efficiency and a guarantee of improved customer service.

The training catalogue includes beginner's courses in electrical distribution, knowledge of MV and LV switchgear, operation and maintenance of installations, design of LV installations to give but a few examples.



<i>Presentation</i>	2
<i>Functions and characteristics</i>	A-1
<i>Installation recommendations</i>	B-1
<b>Interpact INS40 to 160</b>	<b>C-2</b>
<b>Interpact INS250-100 to 630</b>	
<b>Interpact INV100 to 630</b>	<b>C-5</b>
<b>Interpact INS250-100 to 630</b>	
<b>Interpact INV100 to 630</b>	<b>C-6</b>
<b>Interpact INS630b to 1600</b>	
<b>Interpact INV630b to 1600</b>	<b>C-10</b>
<b>Interpact INS2000 to 2500</b>	
<b>Interpact INV2000 to 2500</b>	<b>C-12</b>
<b>Mechanical interlocks for direct and extended handles</b>	<b>C-14</b>
INS40 to 630, INV100 to 630	C-14
<b>Complete source changeover assembly</b>	<b>C-15</b>
INS250-100 to 630, INV100 to 630	C-15
<b>Installation of downstream coupling</b>	<b>C-16</b>
INS250-100 to 630, INV100 to 630	C-16
<b>Front-panel accessories</b>	<b>C-17</b>
INS250-100 to 2500, INV100 to 2500	C-17
<b>Parallel or series connection accessories for direct current</b>	<b>C-18</b>
Interpact INS250-100 to 250	
Interpact INV100 to 250	C-18
Interpact INS320 to 630	
Interpact INV320 to 630	C-19
<i>Additional characteristics</i>	D-1
<i>Catalogue numbers</i>	E-1

## Dimensions

### Front handle

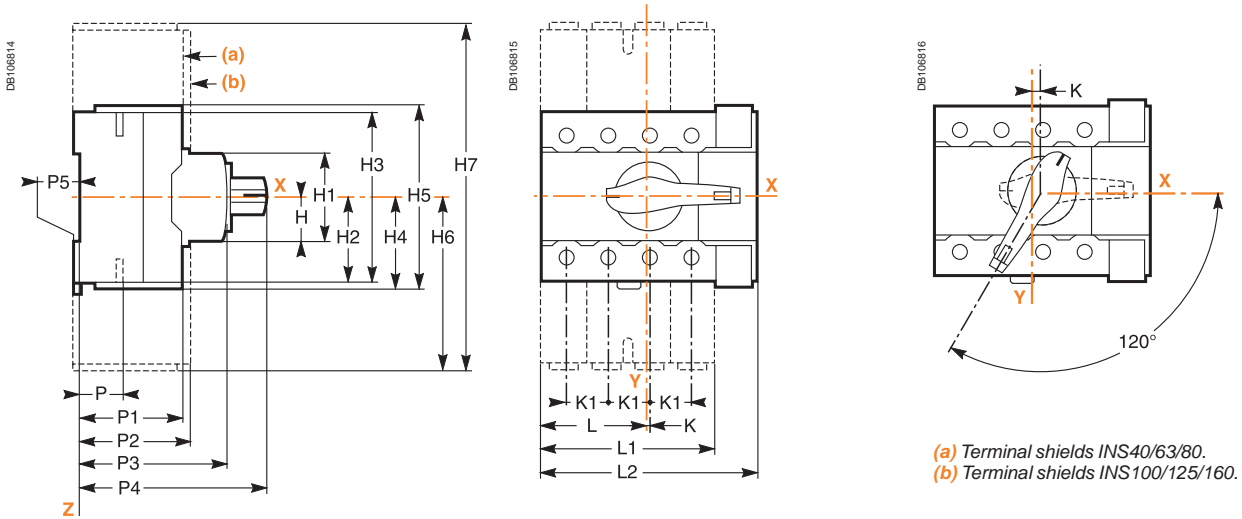

Dimensions (mm)

Type	H	H1	H2	H3	H4	H5	H6	H7	K	K1	L	L1	L2	P	P1	P2	P3	P4	P5
INS40/63/80	22.5	45	40.5	81	42.5	85	73.5	147	1	18	46	73	90	23.3	43	47	62.5	79	5
INS100/125/160	22.5	45	50	100	50	100	110	220	7.5	30	67.5	119	135	21.5	45	47	62.5	79	5

### Extended front handle

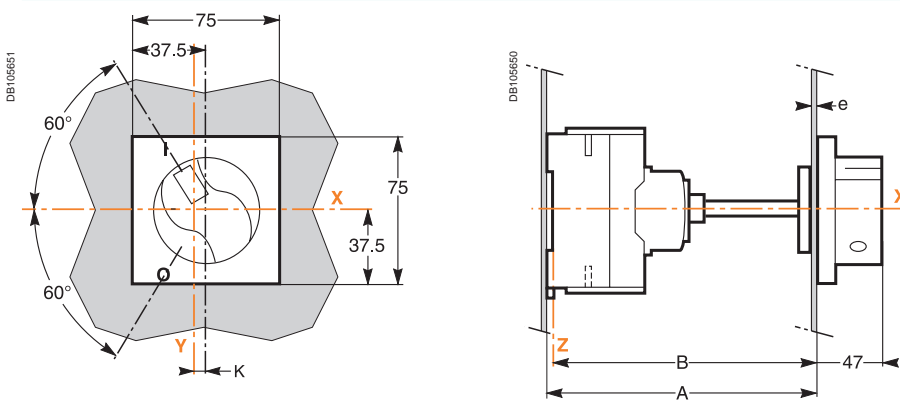

Dimensions (mm)

Type	A (on back plate)		B (on rail)	
	Min.	Max.	Min.	Max.
INS40/63/80	128	519	123	514
INS100/125/160	128	519	123	514

Type	e	K	Length of shaft
INS40/63/80	1...3	1	A - 69
INS100/125/160	1...3	7.5	A - 69

### Door or front panel cutout for front handle

#### Direct

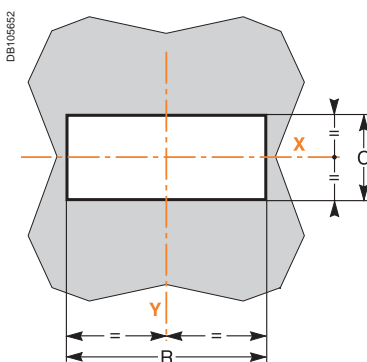

#### Extended

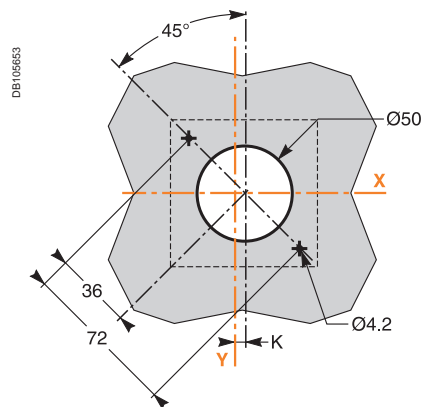

Dimensions (mm)

Type	C	R	K
INS40/63/80	47	92	1
INS100/125/160	47	137	7.5

Note: lines X and Y indicate the axes of symmetry of the switch-disconnector. Reference plane Z corresponds to the back of the switch-disconnector.



## Dimensions

### Lateral handle

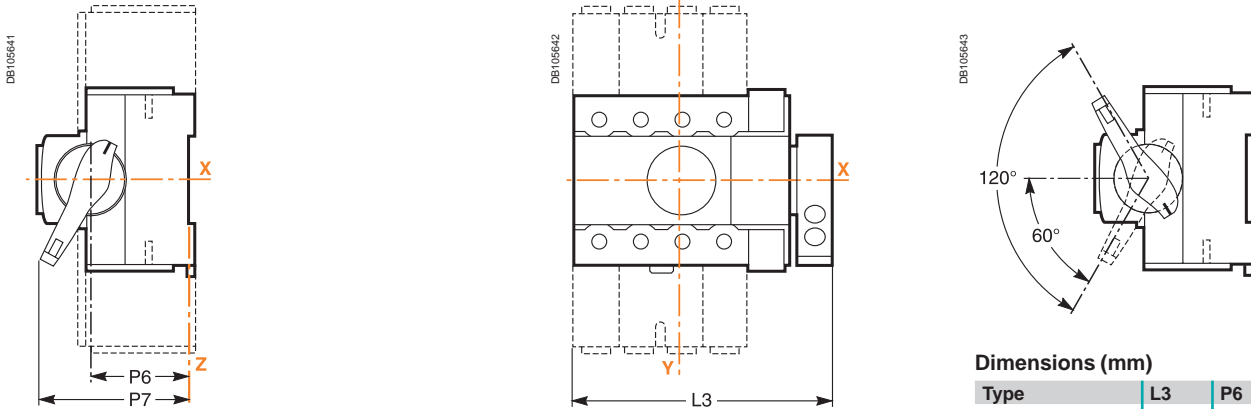

Dimensions (mm)

Type	L3	P6	P7
INS40/63/80	109	40	66.1
INS100/125/160	154	42.5	69.3

### Extended lateral handle

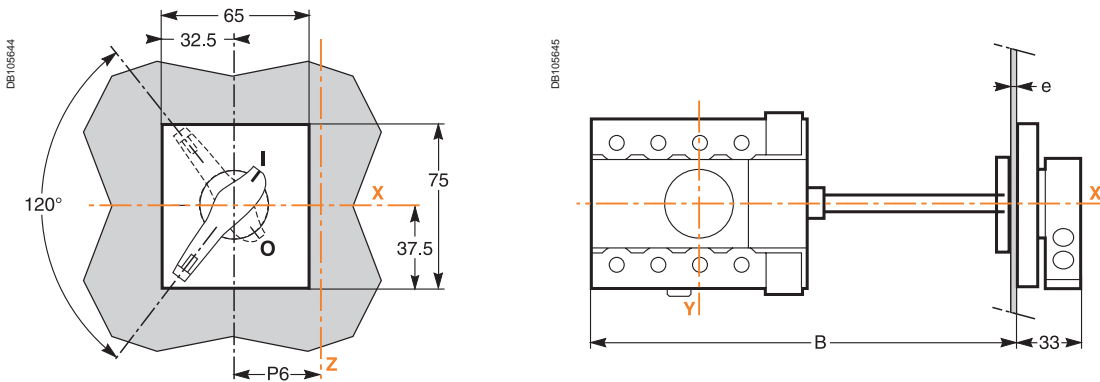

Dimensions (mm)

Type	B		e	P6	Length of shaft
	Min.	Max.			
INS40/63/80	155	396	1...3	40	B - 95
INS100/125/160	200	441	1...3	42.5	B - 140
<b>Without shaft</b>					
INS40/63/80	B		e	P6	
INS40/63/80	102		1...3	40	
INS100/125/160	147		1...3	42.5	

### Lateral handle for functional enclosure

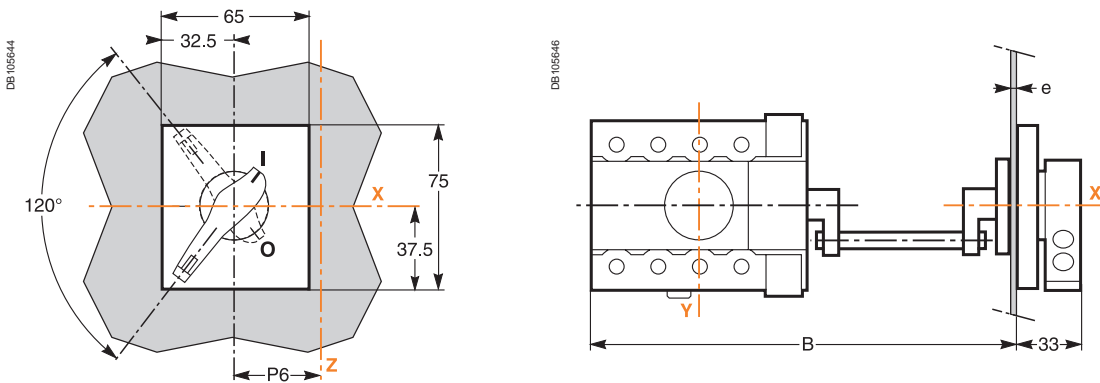

Dimensions (mm)

Type	Enclosure length	Type of shaft	B	e	P6
INS40/63/80	550 mm	Short	149	1...3	41.5
	600 mm	Long	174	1...3	41.5
INS100/125/160	550 mm	Short	194	1...3	41.5
	600 mm	Long	219	1...3	41.5

## Dimensions

### Front panel cutout for extended handle

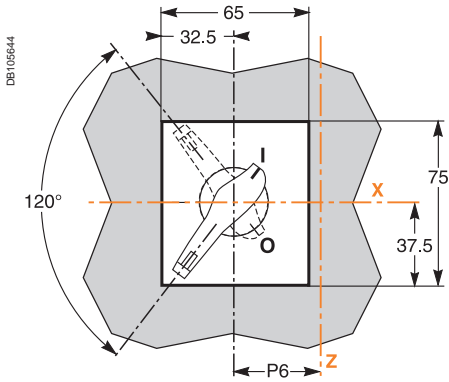

#### Dimensions (mm)

Type	P6
INS40/63/80	40
INS100/125/160	42.5

## Installation

### On a backplate

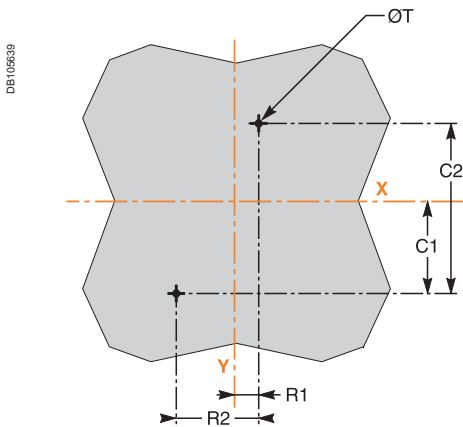

### On rail

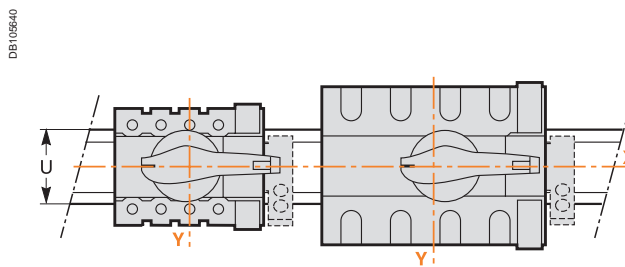

#### Dimensions (mm)

Type	C1	C2	R1	R2	ØT	U
INS40/63/80	40	80	10	36	4.5	35
INS100/125/160	37.5	75	22.5	60	4.5	35

## Dimensions

### Front handle

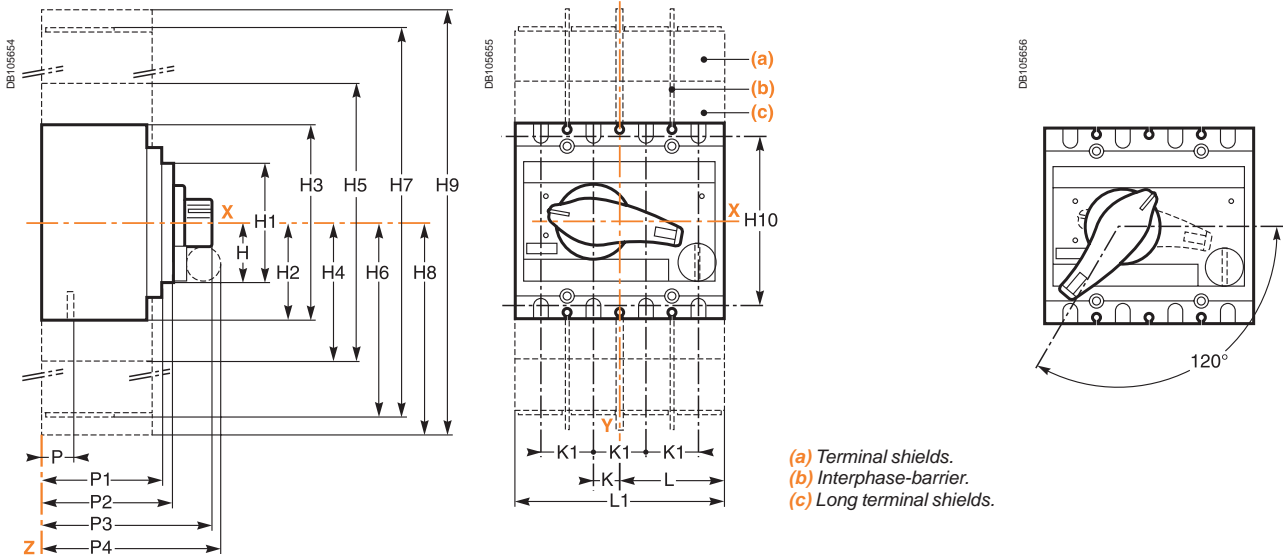

Dimensions (mm)

Type	H	H1	H2	H3	H4	H5	H6	H7	H8	H9	H10	K	K1	L	L1	P	P1	P2	P3	P4
INS250	40	80	68	136	82	164	148	296	166	332	115	17.5	35	70	140	21.5	86	96	131	138
INV100/250																				
INS320/630	61.5	123	102.5	205	118	236	215	430	212.5	425	177	22.5	45	92.5	185	26	120	130	160.4	162
INV320/630																				

### Extended front handle

INS250-100 to 250 and INV100 to 250

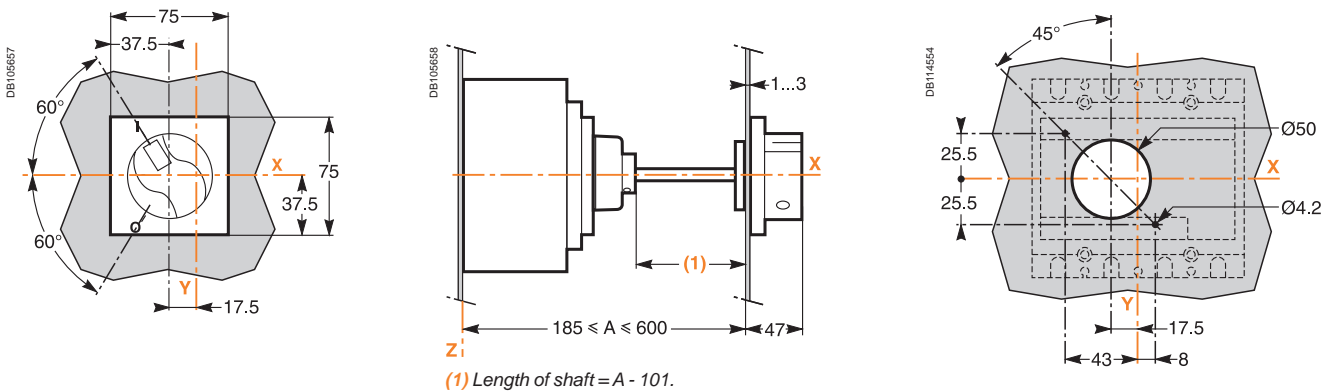

(1) Length of shaft = A - 101.

INS320 to 630 and INV320 to 630

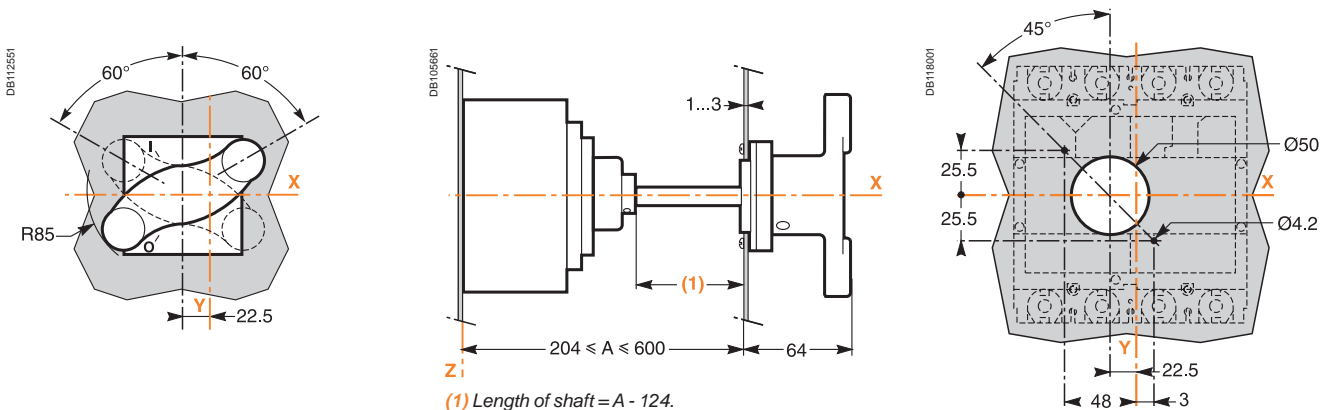

(1) Length of shaft = A - 124.

**Note:**  
Lines X and Y indicate the axes of symmetry of the switch-disconnector.  
Reference plane Z corresponds to the back of the switch-disconnector.

## Door or front panel cutout for front handle

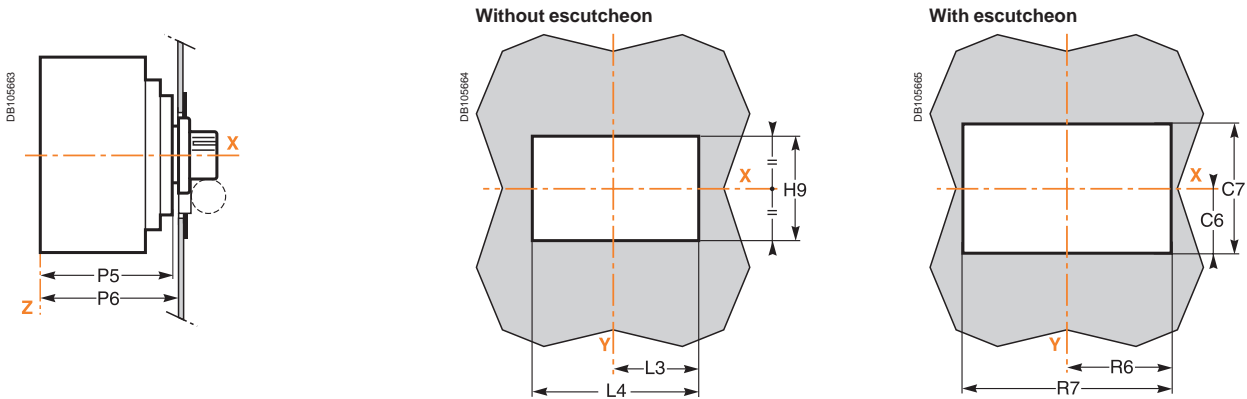

### Dimensions (mm)

Type	C6	C7	H9	L3	L4	P5	P6	R6	R7
INS/INV100 to 250	51.5	103	82	66	132	86	88	81	162
INS/INV320 to 630	76.5	153	127	86	172	110	112	101	202

## Installation

### On panel fixed/FC

### On panel fixed/RC

### On rail

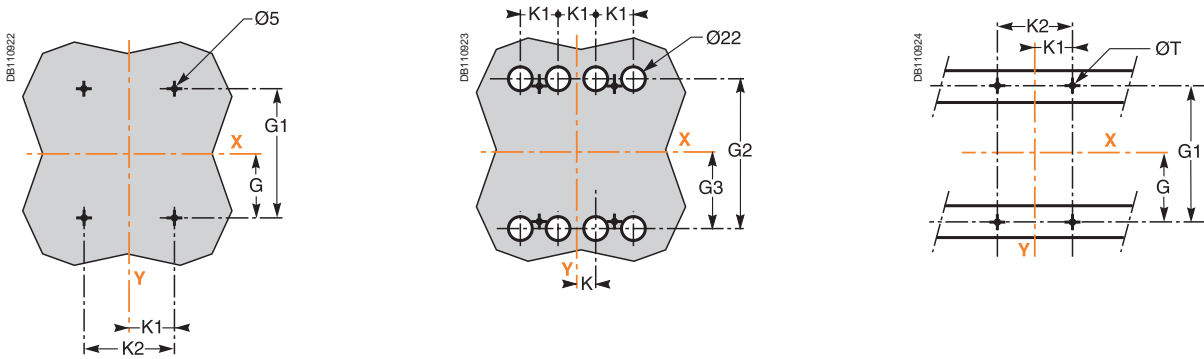

### Dimensions (mm)

Type	G	G1	G2	G3	K	K1	K2	ØT
INS/INV100 to 250	50	100	115	57.5	17.5	35	70	6
INS/INV320 to 630	75	150	177	88.5	22.5	45	90	6

## Front panel cutout

### Switch-disconnector equipped with a voltage-presence indicator

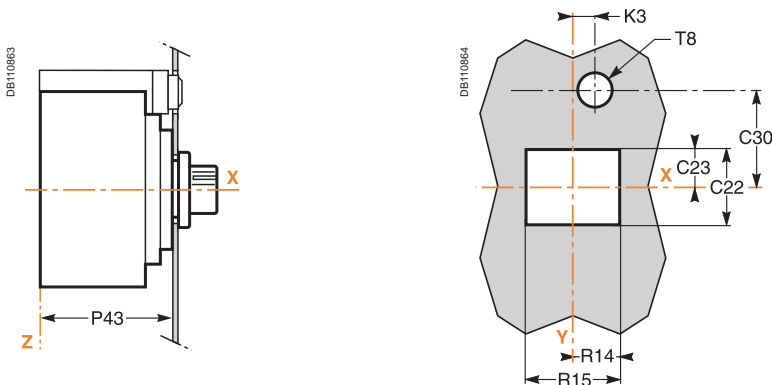

### Dimensions (mm)

Type	P43	R14	R15	C22	C23	C30	T8	K3
INS/INV100 to 250	87.2	65	130	80	40	58.5	31	18
INS/INV320 to 630	112	86	172	125.7	62.85	97	31	22.7

## Dimensions

### Lateral handle (only for INS250-100 to 250 and INV100 to 250)

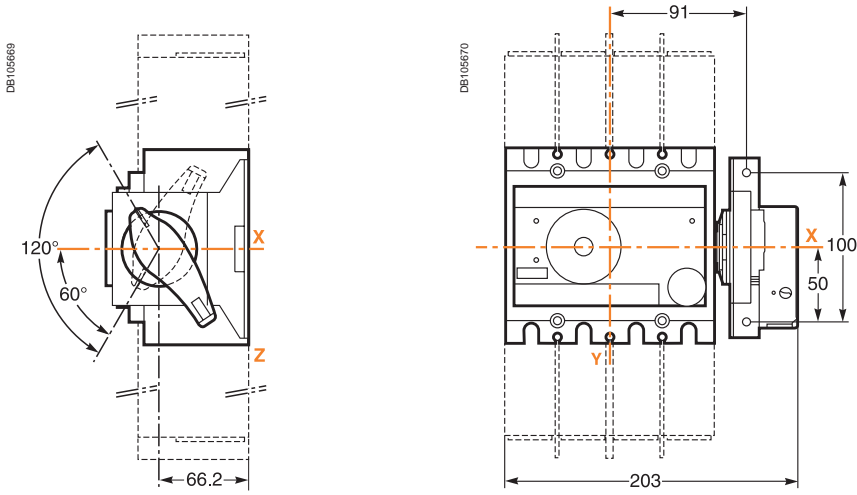

### Extended lateral handle (only for INS250-100 to 250 and INV100 to 250)

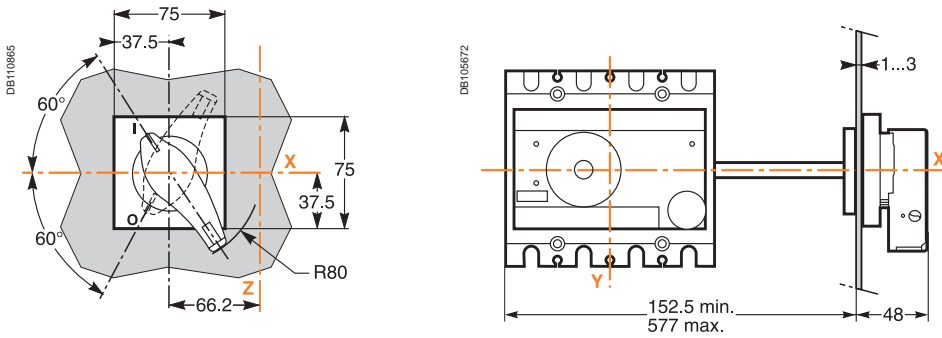

### Door or front panel cutout for lateral handle (only for INS250-100 to 250 and INV100 to 250)

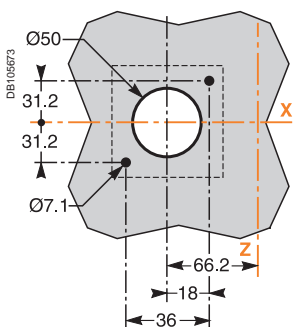

## Dimensions

Switch-disconnector with ammeter module

Switch-disconnector equipped with current transformer

Direct handle (INS250/INV100 to 250)

Extended handle

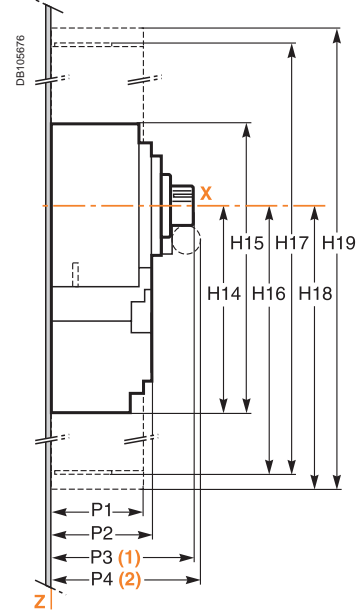
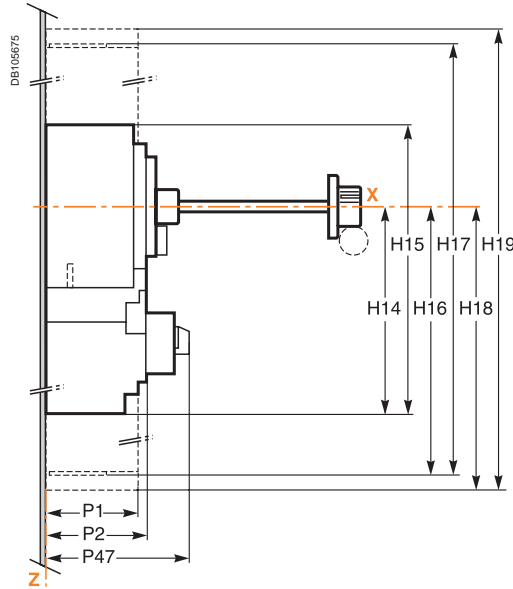
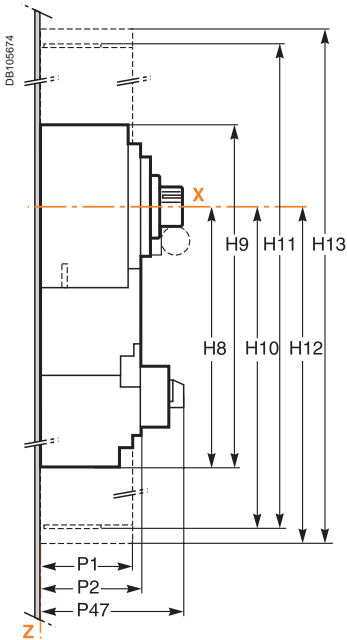

(1) To front of direct handle.  
(2) To front of key.

## Front panel cutout

Switch-disconnector with ammeter module

Direct handle (INS250/INV100 to 250)

Extended handle

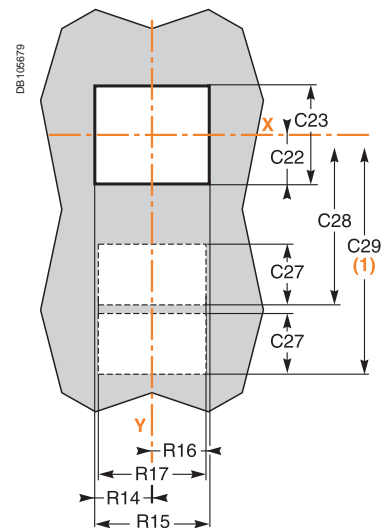
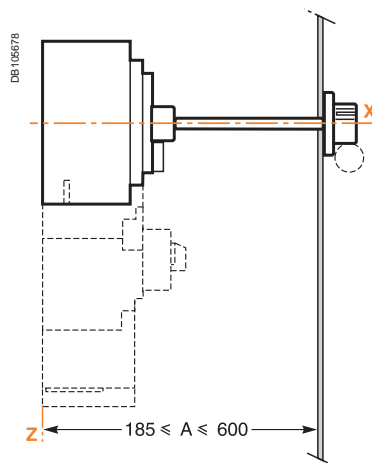
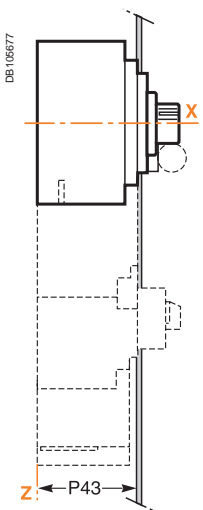

(1) Only for INS250/INV100 to 250 with direct handle and ammeter module.

**Installation (for INS250 direct rotary handle equipped with ammeter module or current transformer)**

On a backplate

On rails

Fixed front connection

Fixed rear connection

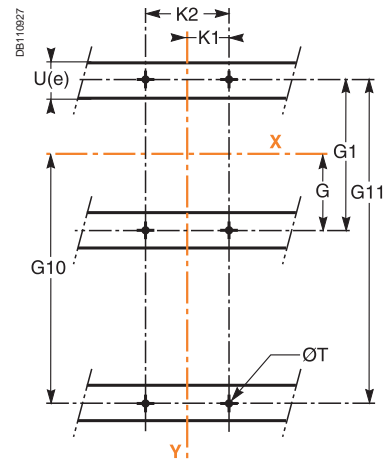
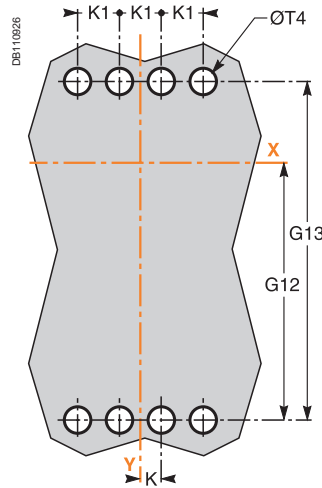
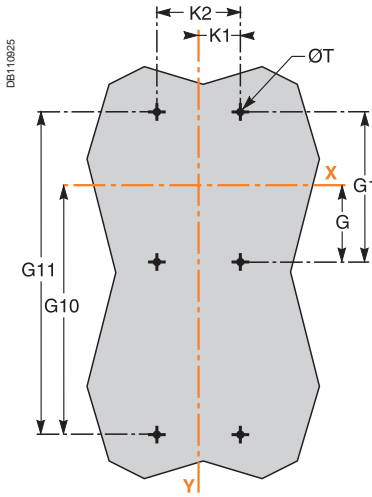

**Installation (for extended rotary handle equipped with ammeter module)**

On a backplate

On rails

Fixed front connection

Fixed rear connection

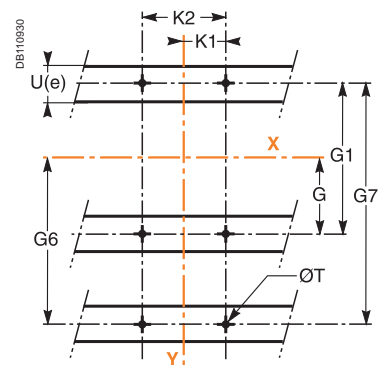
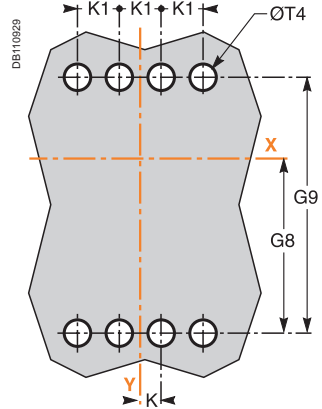
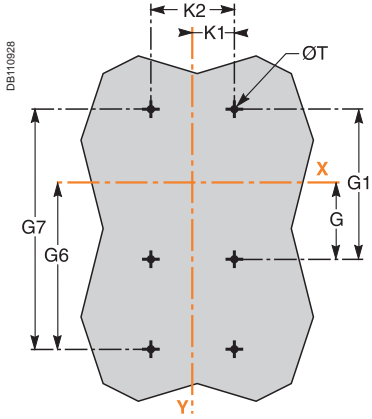

Dimensions (mm)

Type	C22	C23	C27	C28	C29	G	G1	G6	G7	G8	G9	G10	G11	G12	G13
INS/INV100 to 250	41	82	56.5	187	195	50	100	125	175	132.5	190	200	250	207.5	265
INS/INV320 to 630	63.5	127	56.5	162	-	75	150	175	250	188.5	277	175	250	188.5	277

Type	H8	H9	H10	H11	H12	H13	H14	H15	H16	H17	H18	H19
INS/INV100 to 250	216	282	279.5	410	297.5	446	141	207	205	334	223	370
INS/INV320 to 630	-	-	-	-	-	-	202.5	305	310.5	521.5	217.5	530

Type	K	K1	K2	P1	P2	P3	P4	P43	P47	R14	R15	R16	R17	ØT	ØT4	U(e)
INS/INV100 to 250	17.5	35	70	81	86	131	138	89	137	48.5	97	46.5	93	6	22	≤ 32
INS/INV320 to 630	22.5	45	90	95.5	110	160.4	162	112	162	64.5	129	64.5	93	6	32	≤ 32

## Dimensions

### Direct front handle

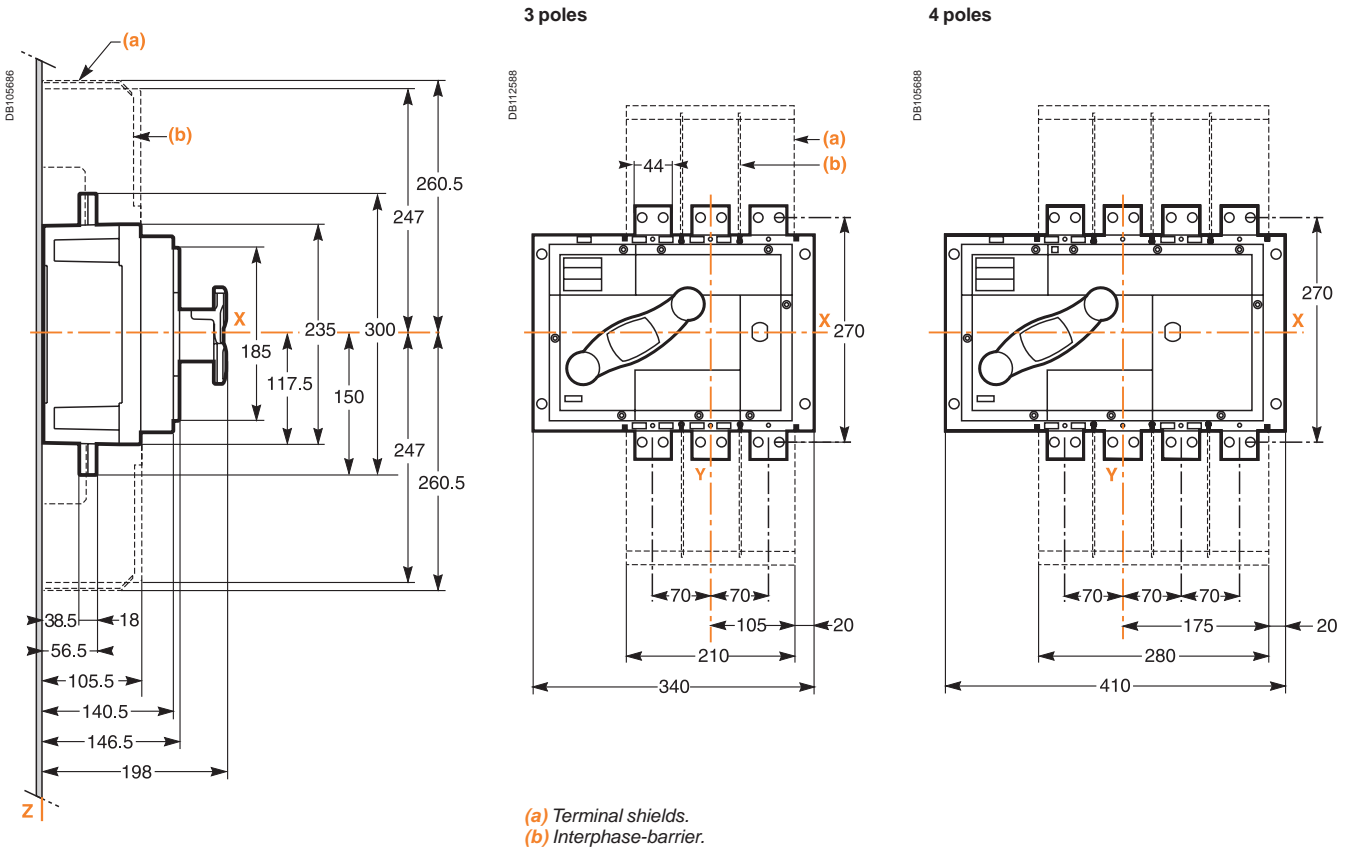

### Door or front panel cutout for extended handle

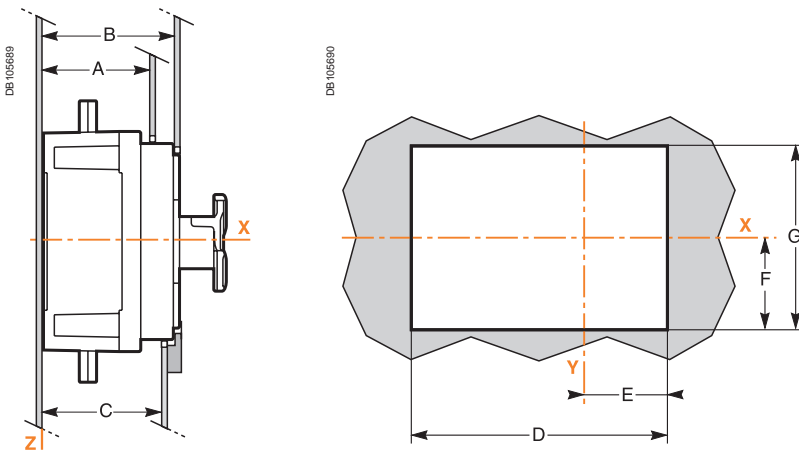

#### Cutout for switch-disconnector cover (mm)

Type	A	D	E	F	G
3P	107	299	103	108	216
4P	107	369	173	108	216

#### Cutout for switch-disconnector front (mm)

Type	B	D	E	F	G
3P	142	274	90,5	95,5	191
4P	142	344	160,5	95,5	191

#### Cutout for escutcheon (mm)

Type	C	D	E	F	G
3P	132	330	120	123	246
4P	132	400	190	123	246

**Note:**  
Lines X and Y indicate the axes of symmetry of the switch-disconnector.  
Reference plane Z corresponds to the back of the switch-disconnector.



**Extended front handle**

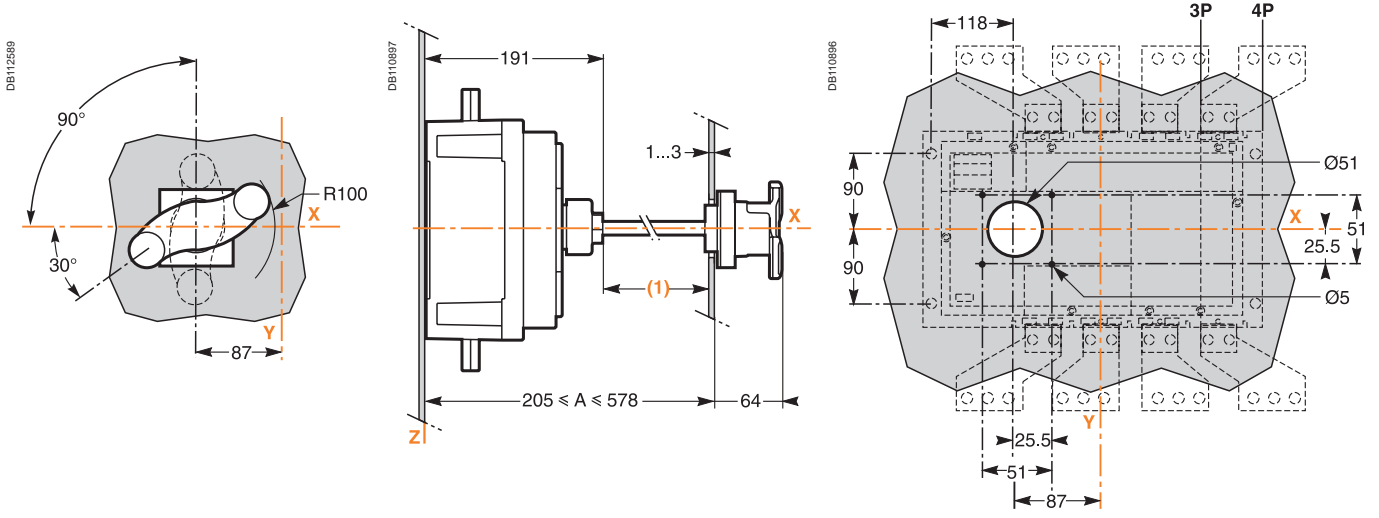

(1) Length of shaft = A - 151.

**Installation**

**On backplate**

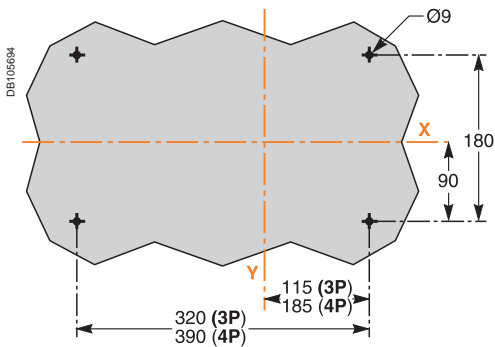

**On rail**

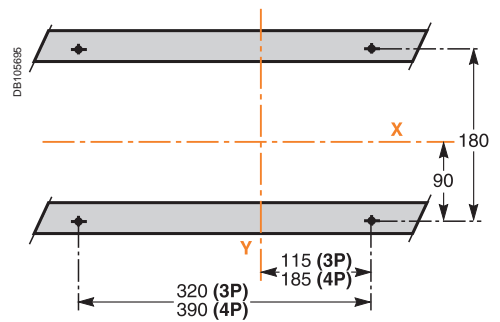

## Dimensions

### Direct front handle

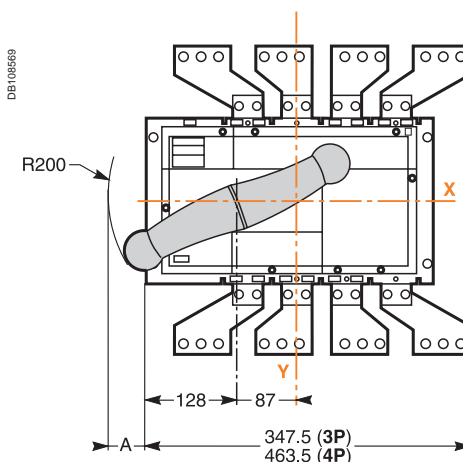
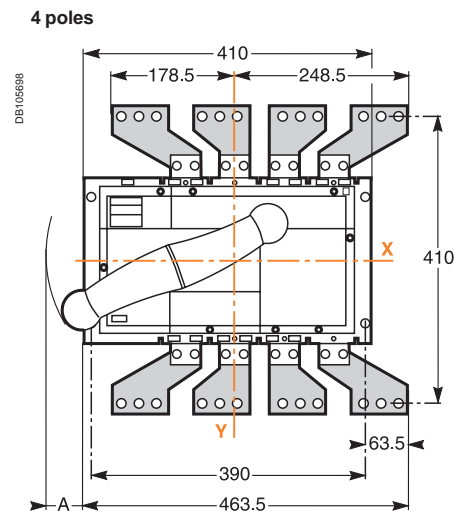
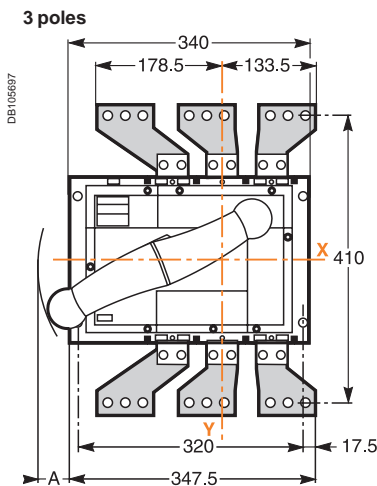
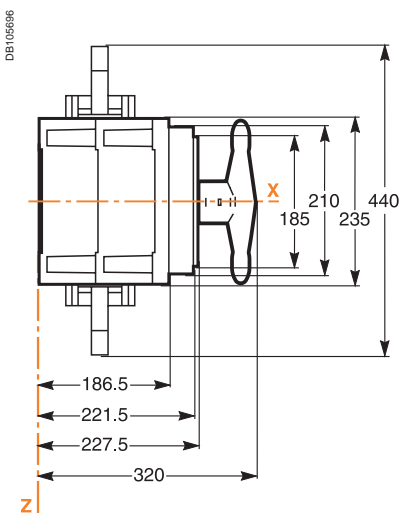

A : 50 min. / 72 max.

### Door or front panel cutout for front handle

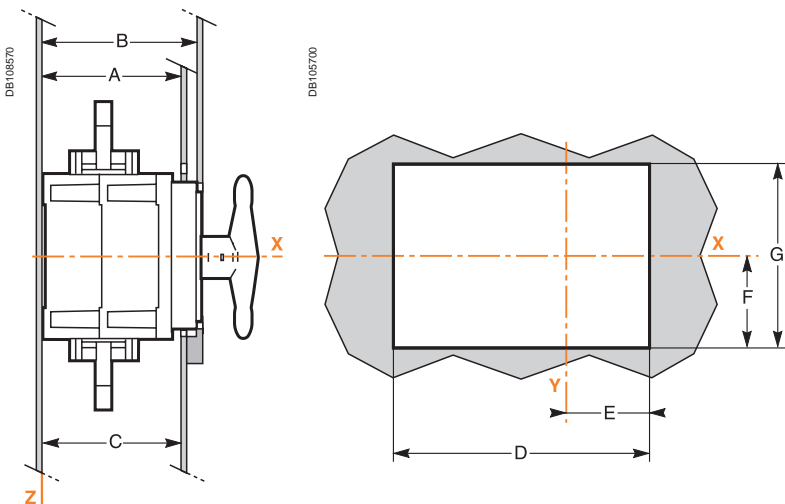

#### Cutout for switch-disconnector cover (mm)

Type	A	D	E	F	G
3P	188	299	103	108	216
4P	188	369	173	108	216

#### Cutout without escutcheon (mm)

Type	B	D	E	F	G
3P	223	274	90,5	95,5	191
4P	223	344	160,5	95,5	191

#### Cutout with escutcheon (mm)

Type	C	D	E	F	G
3P	213	327	110	121,5	243
4P	213	397	180	121,5	243

**Note:**

Lines X and Y indicate the axes of symmetry of the switch-disconnector.  
Reference plane Z corresponds to the back of the switch-disconnector.

## Extended front handle

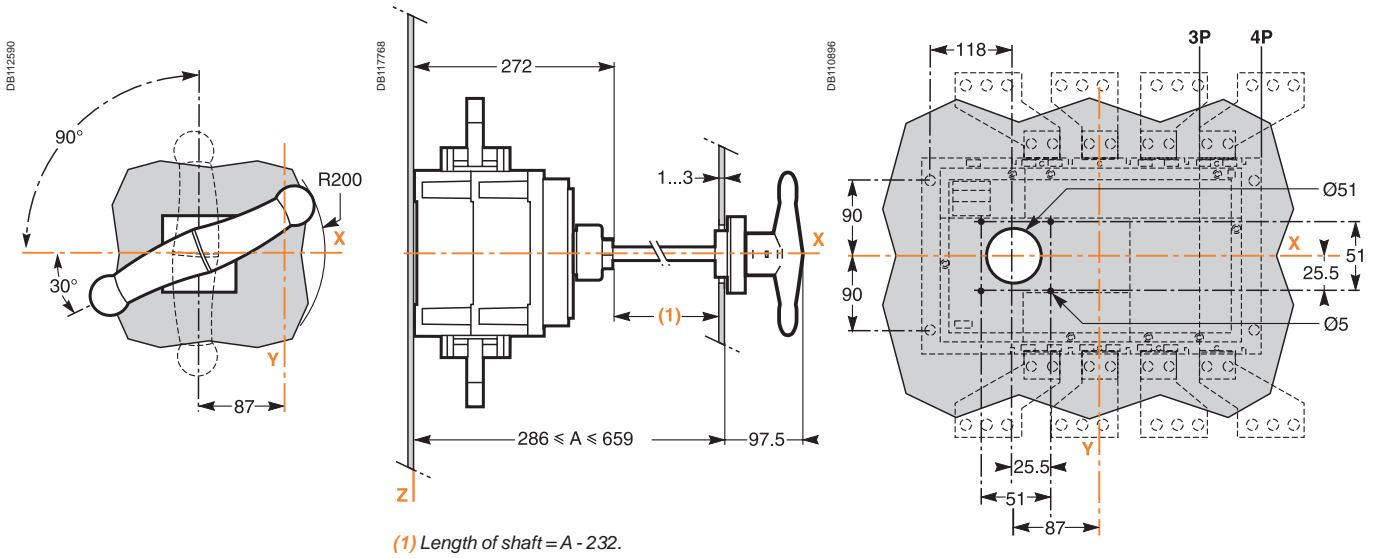

## Installation

### On backplate

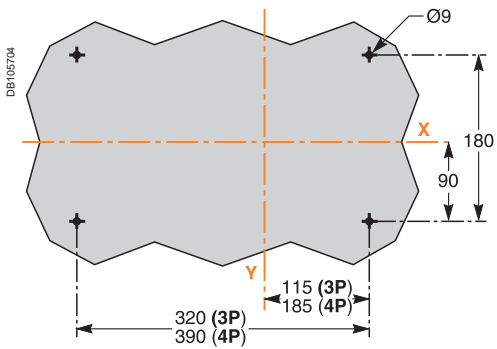

# Mechanical interlocks for direct and extended handles

INS40 to 630, INV100 to 630

## Dimensions for direct handle (INS250-100 to 630 and INV100 to 630)

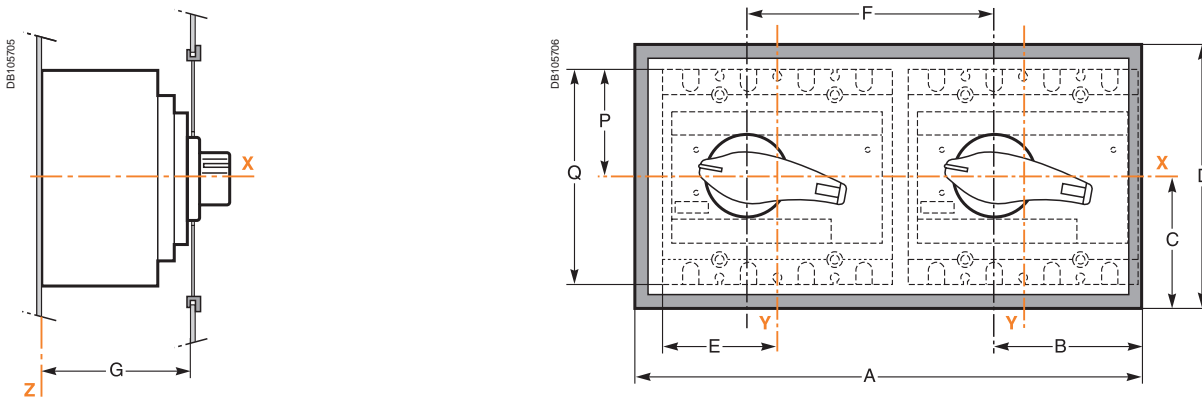

### Door cutout

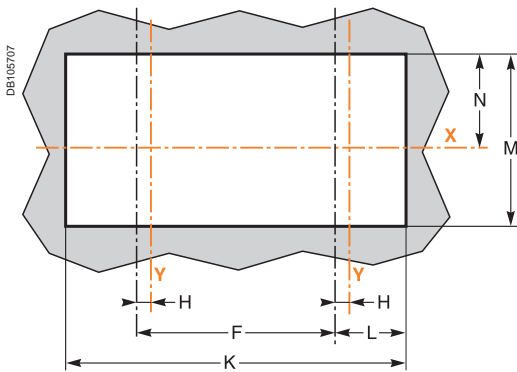

### Dimensions (mm)

Type	A	B	C	D	E	F	G	H	K	L	M	N	P	Q
INS250	325	90	87.5	175	70	156	106	17.5	295	75.5	150	75	68	136
INV100/250														
INS320/630	416	115	100	200	92.5	210	130	22.5	386	100	175	74.5	102.5	205
INV320/630														

## Dimensions for extended handle (INS250-100 to 630 and INV100 to 630)

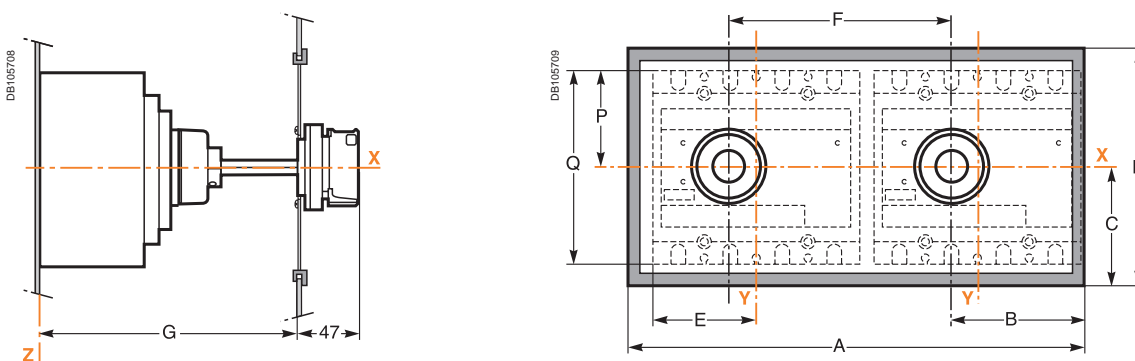

### Door cutout

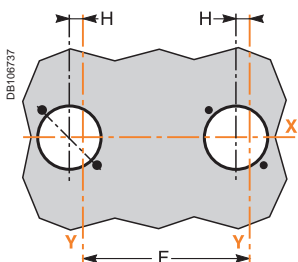

### Dimensions (mm)

Type	A	B	C	D	E	F	G	H	P	Q	
INS40/80	-	-	-	-	46	156	155	396	-	45	90
INS100/160	-	-	-	-	70	156	128	519	-	50	100
INS250	325	90	87.5	175	70	156	185	600	17.5	68	136
INV100/250											
INS320/630	416	115	100	200	92.5	210	204	600	22.5	102.5	205
INV320/630											

**Note:**

Lines X and Y indicate the axes of symmetry of the switch-disconnector. Reference plane Z corresponds to the back of the switch-disconnector.

# Complete source changeover assembly

INS250-100 to 630, INV100 to 630

## Dimensions of the complete source-changeover assembly with a direct handle

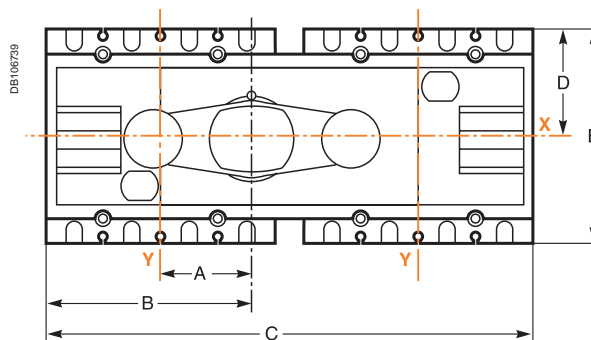
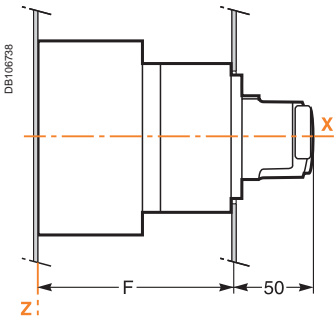

### Front cutout

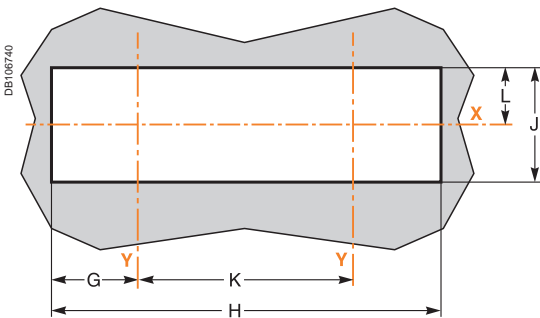

### Dimensions (mm)

Type	A	B	C	D	E	F	G	H	J	K	L
INS250	60.4	130.4	295	68	136	131	61.8	279.3	84	156	42
INS320/630	82.5	175	395	102.5	205	155	87	383.7	128	210	64

## Dimensions of the complete source-changeover assembly with an extended handle

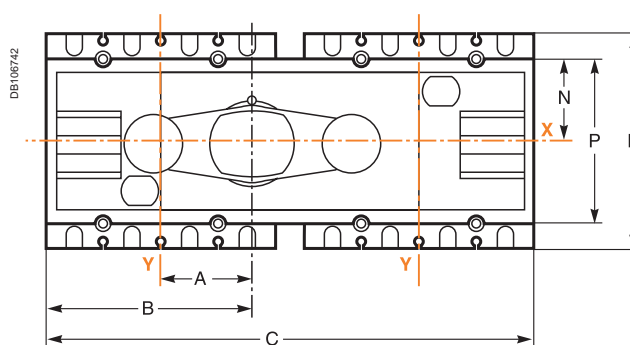
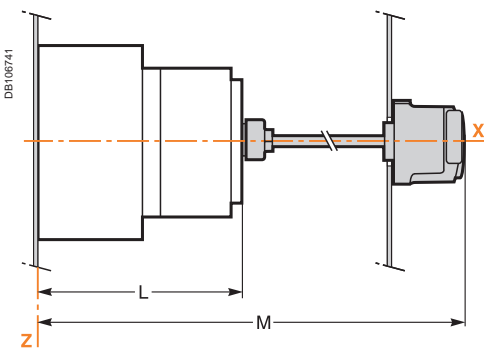

### Door cutout

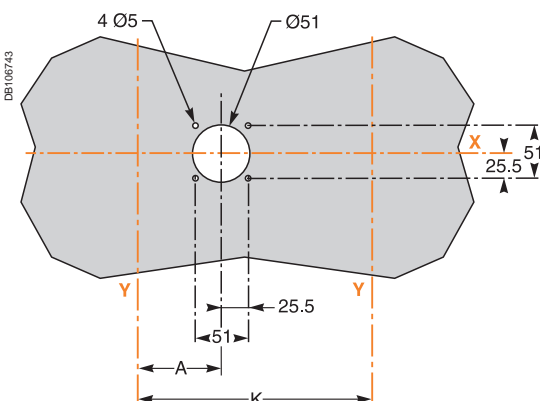

### Dimensions (mm)

Type	A	B	C	E	K	L	M	N	P
INS250	60.4	130.4	295	136	156	138.5	631	50	100
INV100/250									
INS320/630	82.5	175	395	205	210	162.5	658	75	150
INV320/630									

**Note:**

Lines X and Y indicate the axes of symmetry of the switch-disconnector. Reference plane Z corresponds to the back of the switch-disconnector.

# Installation of downstream coupling

INS250-100 to 630, INV100 to 630

## Dimensions

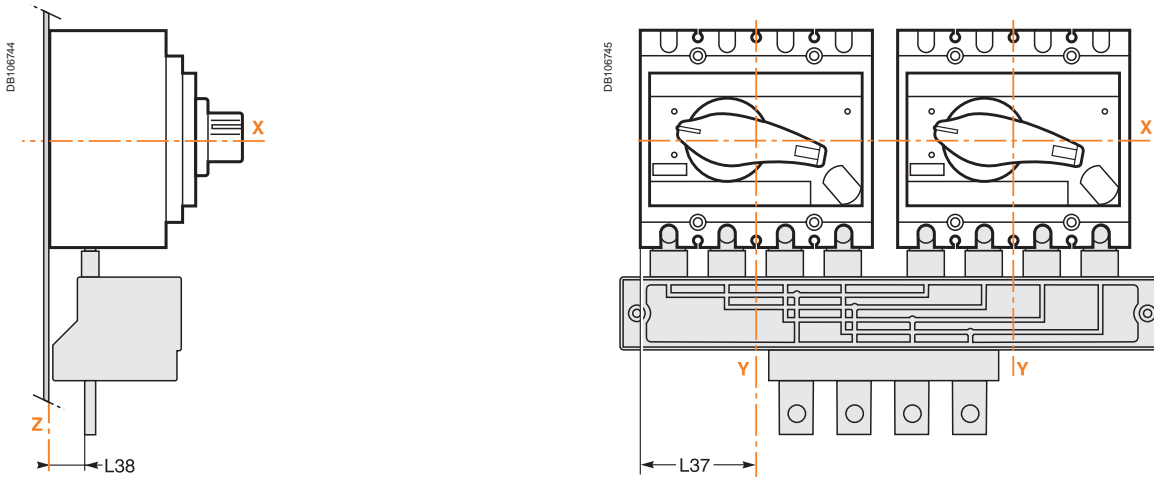

## Dimensions

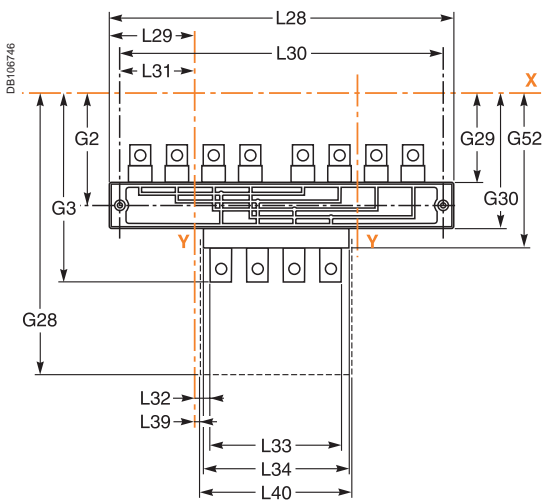

## Connection

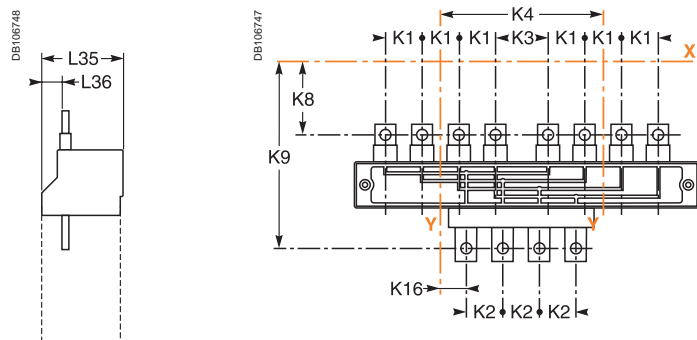

### Dimensions (mm)

Type	G2	G3	G28	G29	G30	G52	K1	K2	K3	K4	K8	K9	K16
INS250	105.5	169	225.2	83.5	127.5	143.5	35	35	51	156	57.5	157.5	25.4
INV100/250													
INS320/630	141	240.7	315	118.4	163.4	202.5	45	52.5	75	210	88.5	225.7	26.1
INV320/630													
Type	L28	L29	L30	L31	L32	L33	L34	L35	L36	L37	L38	L39	L40
INS250	320	82.2	300	72.2	16.4	123	139.5	74.5	19.5	70	21.5	24.9	140
INV100/250													
INS320/630	420	105.2	400	95.2	11.1	187.5	184.7	96.5	24	92.5	26	22.4	210
INV320/630													

**Note:**  
 Lines X and Y indicate the axes of symmetry of the switch-disconnector.  
 Reference plane Z corresponds to the back of the switch-disconnector.

## Front-panel escutcheon

For switch-disconnectors

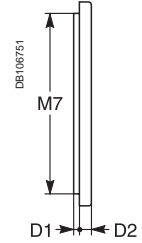
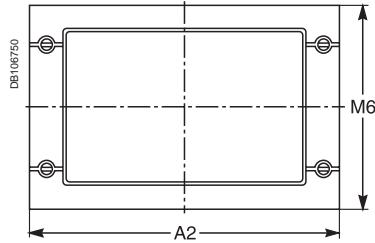
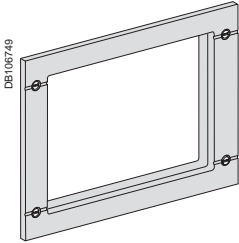

Dimensions (mm)

Type		A2	D1	D2	M6	M7
INS250		174	3.5	6.5	114	101
INV100/250						
INS320/630		215.5	3.5	6.5	164	151
INV320/630						
INS630b/2500	3P	346	3.5	11.5	257.5	242 x 326.5
INV630b/2500	4P	416	3.5	11.5	257.5	242 x 396.5

## For ammeter module

## Connection

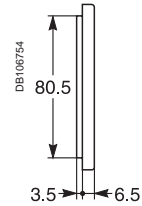
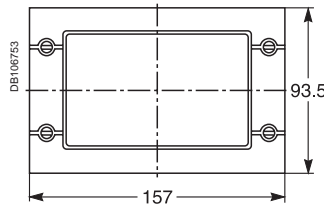
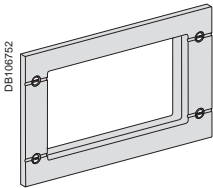

## Front alignment (only for INS/INV250-100)

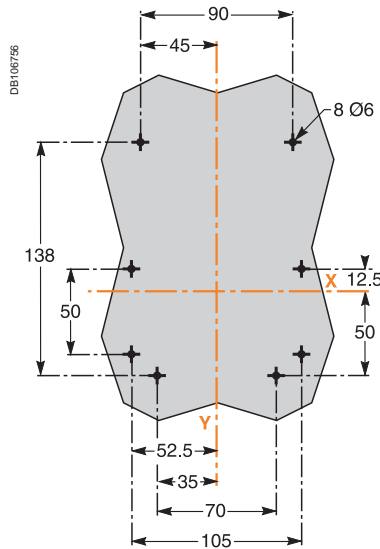
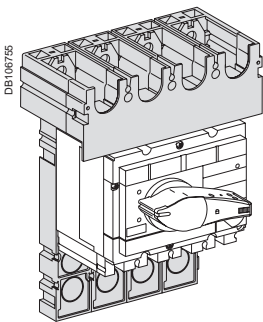

**Note:**

Lines X and Y indicate the axes of symmetry of the switch-disconnector. Reference plane Z corresponds to the back of the switch-disconnector.

# Parallel or series connection accessories for direct current

Interpact INS250-100 to 250  
Interpact INV100 to 250

## With series connections

3P

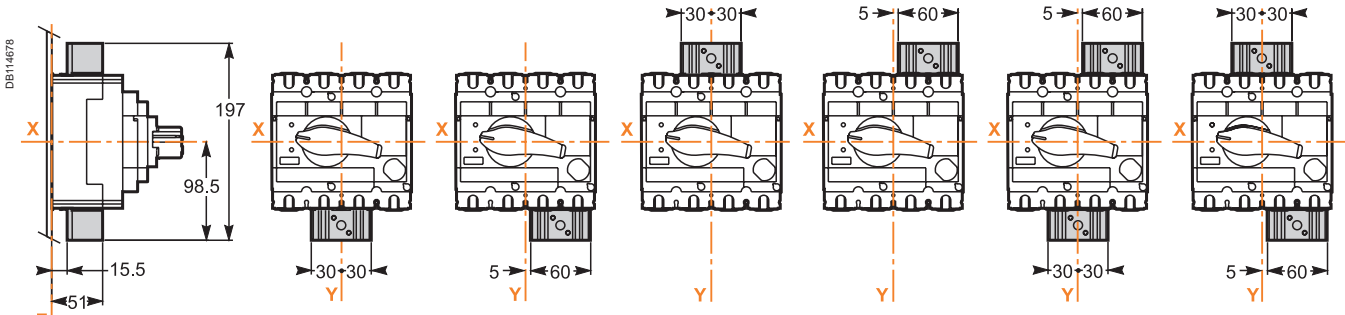

4P

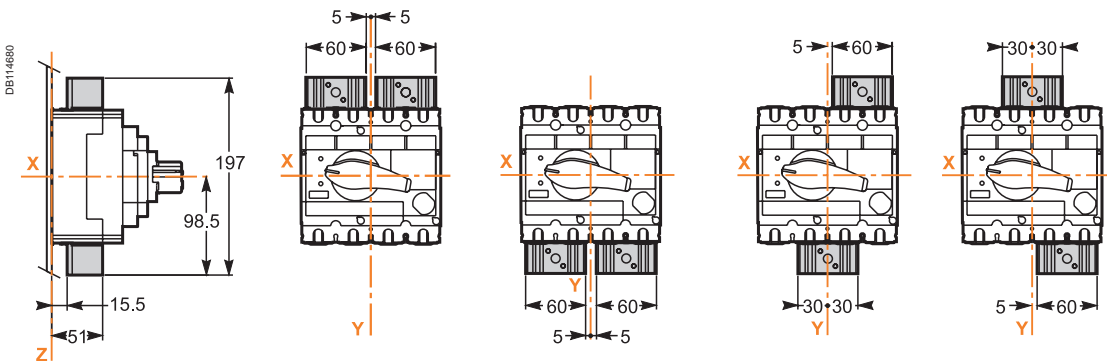

## With parallel connections

3P

4P

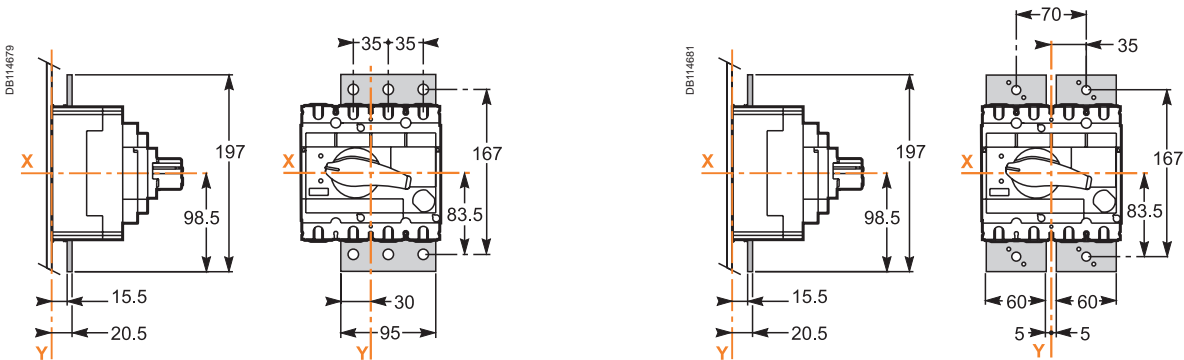



# Parallel or series connection accessories for direct current

Interpact INS320 to 630

Interpact INV320 to 630

## With series connections

3P

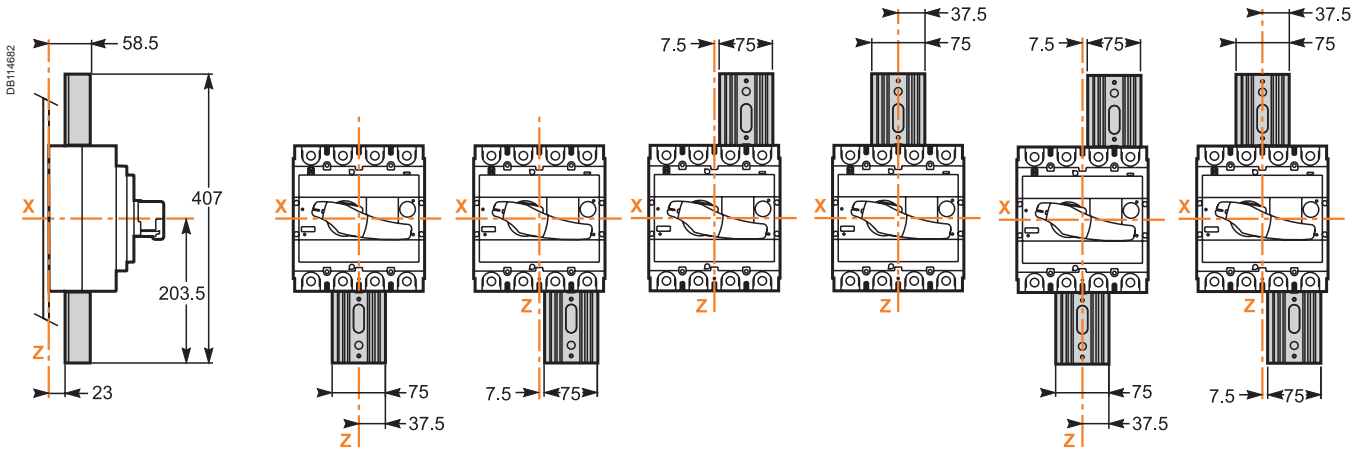

4P

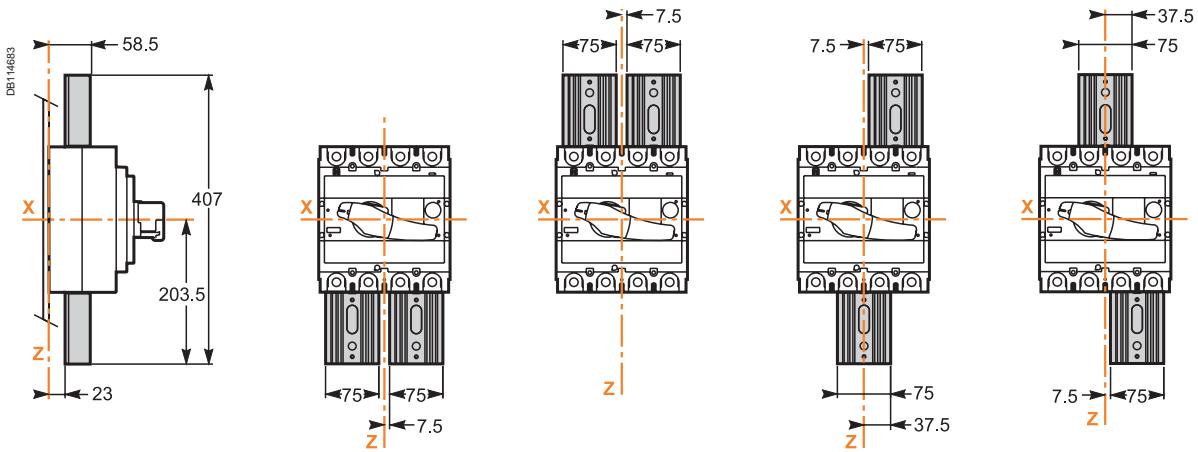

## With parallel connections

4P

3P<sup>(1)</sup>

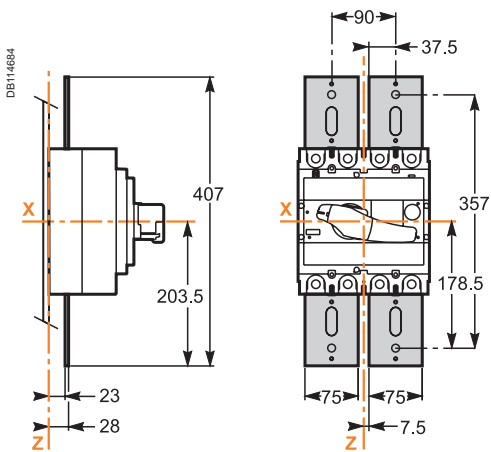

(1) Connection to be made by customer.

## schneider-electric.com

This international site allows you to access all the Schneider Electric products in just 2 clicks via comprehensive range data-sheets, with direct links to:

- complete library: technical documents, catalogs, FAQs, brochures...

- selection guides from the e-catalog.

- product discovery sites and their Flash animations.

You will also find illustrated overviews, news to which you can subscribe, the list of country contacts...



## The electrical installation guide

### According to IEC 60364

This guide, part of the Schneider Electric offer, is the essential tool to "guide" you any time in your business:

- design office, consultant
- contractor, panelbuilder
- teacher, trainer.

### Comprehensive and concrete information on:

- all the new technical solutions
- all the components
- of an installation from a global point of view
- all the IEC standards modifications
- all the fundamental electrotechnical knowledge
- all the design stages, from medium to low voltage.



---

<i>Presentation</i>	2
<i>Functions and characteristics</i>	A-1
<i>Installation recommendations</i>	B-1
<i>Dimensions and connection</i>	C-1
<b>Protection of switch-disconnectors</b>	<b>D-2</b>
INS40 to INS160 by Compact NSX circuit breaker	D-2
INS/INV100 to INS/INV630 by Compact NSX circuit breaker	D-8
INS40 to INS160 by Compact NS circuit breaker	D-12
INS/INV100 to INS/INV630 by Compact NS circuit breaker	D-14
INS/INV630b to INS/INV2500 by Compact NS circuit breaker	D-16
INS/INV630b to INS/INV2500 by Masterpact NT and NW circuit breakers	D-18
INS40 to 2500 and INV100 to 2500 by fuses	D-20
<b>Characteristics of switch-disconnectors</b>	<b>D-22</b>
INS40 to 2500 and INV100 to 2500 for direct current	D-22
<i>Catalogue numbers</i>	E-1

# Protection of switch-disconnectors INS40 to INS160 by Compact NSX circuit breaker

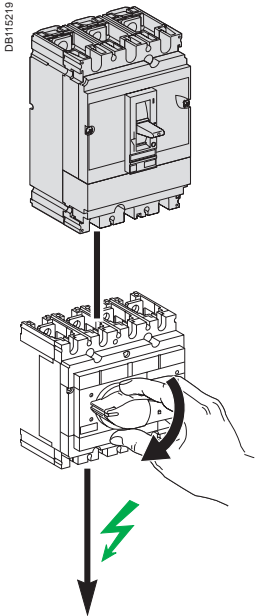

Interpact INS switch-disconnectors		
Upstream protection		
By Compact NSX		
By circuit breaker 380/415 V		
Type/maximum rating (A)		
Isc max.		kA rms
Making capacity		kA peak
Type/maximum rating (A)		
Isc max.		kA rms
Making capacity		kA peak
Type/maximum rating (A)		
Isc max.		kA rms
Making capacity		kA peak
Type/maximum rating (A)		
Isc max.		kA rms
Making capacity		kA peak
Type/maximum rating (A)		
Isc max.		kA rms
Making capacity		kA peak
Type/maximum rating (A)		
Isc max.		kA rms
Making capacity		kA peak
Type/maximum rating (A)		
Isc max.		kA rms
Making capacity		kA peak
Type/maximum rating (A)		
Isc max.		kA rms
Making capacity		kA peak
Type/maximum rating (A)		
Isc max.		kA rms
Making capacity		kA peak
Type/maximum rating (A)		
Isc max.		kA rms
Making capacity		kA peak
Type/maximum rating (A)		
Isc max.		kA rms
Making capacity		kA peak
Type/maximum rating (A)		
Isc max.		kA rms
Making capacity		kA peak
Type/maximum rating (A)		
Isc max.		kA rms
Making capacity		kA peak
Type/maximum rating (A)		
Isc max.		kA rms
Making capacity		kA peak

# Protection of switch- disconnectors

## INS40 to INS160 by Compact NSX circuit breaker

	INS40	INS63	INS80	INS100	INS125	INS160
	NSX100B/40 25 52	NSX100B/63 25 52	NSX100B/80 25 52	NSX100B/100 25 52	-	-
	NSX100F/40 36 75	NSX100F/63 36 75	NSX100F/80 36 75	NSX100F/100 36 75	-	-
	NSX100N/40 36 75	NSX100N/63 36 75	NSX100N/80 36 75	NSX100N/100 36 75	-	-
	NSX100H/S/L/40 36 75	NSX100H/S/L/63 36 75	NSX100H/S/L/80 36 75	NSX100H/S/L/100 36 75	-	-
	NSX160B/40 25 52	NSX160B/63 25 52	NSX160B/80 25 52	NSX160B/100 25 52	NSX160B/125 25 52	NSX160B/160 25 52
	NSX160F/40 25 52	NSX160F/63 25 52	NSX160F/80 25 52	NSX160F/100 36 75	NSX160F/125 36 75	NSX160F/160 36 75
	NSX160N/40 25 52	NSX160N/63 25 52	NSX160N/80 25 52	NSX160N/100 50 105	NSX160N/125 50 105	NSX160N/160 50 105
	NSX160H/S/L/40 25 52	NSX160H/S/L/63 25 52	NSX160H/S/L/80 25 52	NSX160H/S/L/100 70 154	NSX160H/S/L/125 70 154	NSX160H/S/L/160 70 154
	-	-	-	NSX250B/100 25 52	NSX250B/125 25 52	NSX250B/160 25 52
	-	-	-	NSX250F/100 36 75	NSX250F/125 36 75	NSX250F/160 36 75
	-	-	-	NSX250N/100 50 105	NSX250N/125 50 105	NSX250N/160 50 105
	-	-	-	NSX250H/S/L/100 70 154	NSX250H/S/L/125 70 154	NSX250H/S/L/160 70 154
	NCS100N/40 18 37	NCS100N/63 18 37	NCS100N/80 18 37	NCS100N/100 18 37	-	-
	NG125N/40 25 52	NG125N/63 25 52	NG125N/80 25 52	NG125N/100 25 52	NG125N/125 25 52	-
	NG125H/40 36 75	NG125H/63 36 75	NG125H/80 36 75	-	-	-
	NG125L/40 50 105	NG125L/63 50 105	NG125L/80 50 105	-	-	-
	NG160N/40 30 63	NG160N/63 30 63	NG160N/80 30 63	NG160N/100 30 63	NG160N/125 30 63	NG160N/160 30 63

# Protection of switch-disconnectors INS40 to INS160 by Compact NSX circuit breaker

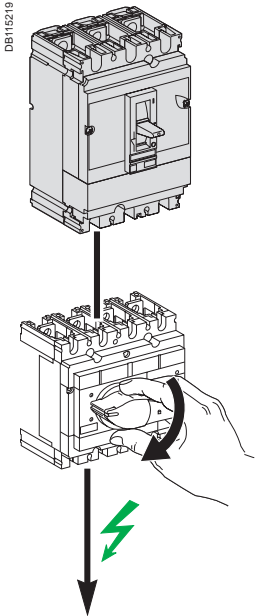

Interpact INS switch-disconnectors		
Upstream protection		
<b>By circuit breaker 440/480 V <sup>(1)</sup></b>	Type/maximum rating (A)	
	Isc max.	kA rms
	Making capacity	kA peak
	Type/maximum rating (A)	
	Isc max.	kA rms
	Making capacity	kA peak
	Type/maximum rating (A)	
	Isc max.	kA rms
	Making capacity	kA peak
	Type/maximum rating (A)	
	Isc max.	kA rms
	Making capacity	kA peak
	Type/maximum rating (A)	
	Isc max.	kA rms
	Making capacity	kA peak
	Type/maximum rating (A)	
	Isc max.	kA rms
	Making capacity	kA peak
	Type/maximum rating (A)	
	Isc max.	kA rms
	Making capacity	kA peak
	Type/maximum rating (A)	
	Isc max.	kA rms
	Making capacity	kA peak
	Type/maximum rating (A)	
	Isc max.	kA rms
	Making capacity	kA peak
	Type/maximum rating (A)	
	Isc max.	kA rms
	Making capacity	kA peak
	Type/maximum rating (A)	
	Isc max.	kA rms
	Making capacity	kA peak
	Type/maximum rating (A)	
	Isc max.	kA rms
	Making capacity	kA peak
<b>By circuit breaker 500/525 V</b>	Type/maximum rating (A)	
	Isc max.	kA rms
	Making capacity	kA peak
	Type/maximum rating (A)	
	Isc max.	kA rms
	Making capacity	kA peak
	Type/maximum rating (A)	
	Isc max.	kA rms
	Making capacity	kA peak
	Type/maximum rating (A)	
	Isc max.	kA rms
	Making capacity	kA peak
	Type/maximum rating (A)	
	Isc max.	kA rms
	Making capacity	kA peak
	Type/maximum rating (A)	
	Isc max.	kA rms
	Making capacity	kA peak
	Type/maximum rating (A)	
	Isc max.	kA rms
	Making capacity	kA peak
	Type/maximum rating (A)	
	Isc max.	kA rms
	Making capacity	kA peak
	Type/maximum rating (A)	
	Isc max.	kA rms
	Making capacity	kA peak
	Type/maximum rating (A)	
	Isc max.	kA rms
	Making capacity	kA peak
	Type/maximum rating (A)	
	Isc max.	kA rms
	Making capacity	kA peak
	Type/maximum rating (A)	
	Isc max.	kA rms
	Making capacity	kA peak
	Type/maximum rating (A)	
	Isc max.	kA rms
	Making capacity	kA peak

<sup>(1)</sup> Applicable for 480 NEMA.

# Protection of switch-disconnectors

## INS40 to INS160 by Compact NSX circuit breaker

	INS40	INS63	INS80	INS100	INS125	INS160
	NSX100B/40 20 40	NSX100B/63 20 40	NSX100B/80 20 40	NSX100B/100 20 40	-	-
	NSX100F/40 35 73	NSX100F/63 35 73	NSX100F/80 35 73	NSX100F/100 35 73	-	-
	NSX100N/40 35 73	NSX100N/63 35 73	NSX100N/80 35 73	NSX100N/100 35 73	-	-
	NSX100H/S/L/40 35 73	NSX100H/S/L/63 35 73	NSX100H/S/L/80 35 73	NSX100H/S/L/100 65 143	-	-
	NSX160B/40 20 40	NSX160B/63 20 40	NSX160B/80 20 40	NSX160B/100 20 40	NSX160B/125 20 40	NSX160B/160 20 40
	NSX160F/40 25 52	NSX160F/63 25 52	NSX160F/80 25 52	NSX160F/100 35 73	NSX160F/125 35 73	NSX160F/160 35 73
	NSX160N/40 25 52	NSX160N/63 25 52	NSX160N/80 25 52	NSX160N/100 35 73	NSX160N/125 35 73	NSX160N/160 35 73
	NSX160H/S/L/40 25 52	NSX160H/S/L/63 25 52	NSX160H/S/L/80 25 52	NSX160H/S/L/100 65 143	NSX160H/S/L/125 65 143	NSX160H/S/L/160 65 143
	-	-	-	NSX250B/100 20 40	NSX250B/125 20 40	NSX250B/160 20 40
	-	-	-	NSX250F/100 35 73	NSX250F/125 35 73	NSX250F/160 35 73
	-	-	-	NSX250N/100 35 73	NSX250N/125 35 73	NSX250N/160 35 73
	-	-	-	NSX250H/S/L/100 65 143	NSX250H/S/L/125 65 143	NSX250H/S/L/160 65 143
	NSC100N/40 18 37	NSC100N/63 18 37	NSC100N/80 18 37	NSC100N/100 18 37	-	-
	NSX100B/40 15 30	NSX100B/63 15 30	NSX100B/80 15 30	NSX100B/100 15 30	-	-
	NSX100F/40 18 36	NSX100F/63 18 36	NSX100F/80 18 36	NSX100F/100 18 36	-	-
	NSX100N/40 18 36	NSX100N/63 18 36	NSX100N/80 18 36	NSX100N/100 18 36	-	-
	NSX100H/S/L/40 25 53	NSX100H/S/L/63 25 53	NSX100H/S/L/80 25 53	NSX100H/S/L/100 25 53	-	-
	NSX160B/40 15 30	NSX160B/63 15 30	NSX160B/80 15 30	NSX160B/100 15 30	NSX160B/125 15 30	NSX160B/160 15 30
	NSX160F/40 15 30	NSX160F/63 15 30	NSX160F/80 15 30	NSX160F/100 15 30	NSX160F/125 22 46	NSX160F/160 22 46
	NSX160N/40 15 30	NSX160N/63 15 30	NSX160N/80 15 30	NSX160N/100 15 30	NSX160N/125 22 46	NSX160N/160 22 46
	NSX160H/S/L/40 15 30	NSX160H/S/L/63 15 30	NSX160H/S/L/80 15 30	NSX160H/S/L/100 22 46	NSX160H/S/L/125 22 46	NSX160H/S/L/160 22 46
	-	-	-	NSX250B/100 15 30	NSX250B/125 15 30	NSX250B/160 15 30
	-	-	-	NSX250F/100 15 30	NSX250F/125 22 46	NSX250F/160 22 46
	-	-	-	NSX250N/100 15 30	NSX250N/125 22 46	NSX250N/160 22 46
	-	-	-	NSX250H/S/L/100 22 46	NSX250H/S/L/125 22 46	NSX250H/S/L/160 22 46
	NSC100N/40 18 37	NSC100N/63 18 37	NSC100N/80 18 37	NSC100N/100 18 37	-	-

# Protection of switch-disconnectors

## INS40 to INS160 by Compact NSX circuit breaker

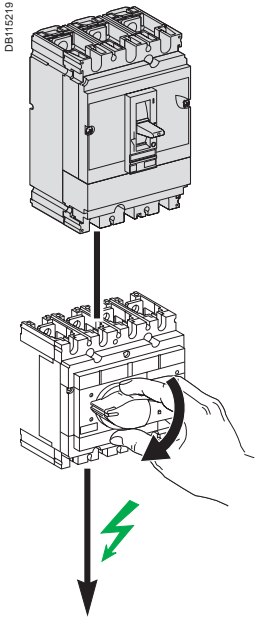

### Interpact INS switch-disconnectors

#### Upstream protection

##### By Compact NSX

##### By circuit breaker 690 V

Type/maximum rating (A)	
Isc max.	kA rms
Making capacity	kA peak
Type/maximum rating (A)	
Isc max.	kA rms
Making capacity	kA peak
Type/maximum rating (A)	
Isc max.	kA rms
Making capacity	kA peak
Type/maximum rating (A)	
Isc max.	kA rms
Making capacity	kA peak
Type/maximum rating (A)	
Isc max.	kA rms
Making capacity	kA peak
Type/maximum rating (A)	
Isc max.	kA rms
Making capacity	kA peak
Type/maximum rating (A)	
Isc max.	kA rms
Making capacity	kA peak
Type/maximum rating (A)	
Isc max.	kA rms
Making capacity	kA peak
Type/maximum rating (A)	
Isc max.	kA rms
Making capacity	kA peak
Type/maximum rating (A)	
Isc max.	kA rms
Making capacity	kA peak
Type/maximum rating (A)	
Isc max.	kA rms
Making capacity	kA peak
Type/maximum rating (A)	
Isc max.	kA rms
Making capacity	kA peak

#### Upstream protection by fuse

##### By 500 V fuse

Type aM <sup>(2)</sup> /maximum rating (A)	
Isc max.	kA rms
Making capacity	kA peak
Type gG <sup>(3)</sup> /maximum rating (A)	
Isc max.	kA rms
Making capacity	kA peak
Type gG <sup>(2)</sup> /maximum rating (A)	
Isc max.	kA rms
Making capacity	kA peak
Type BS <sup>(3)</sup> /maximum rating (A)	
Isc max.	kA rms
Making capacity	kA peak
Type BS <sup>(2)</sup> /maximum rating (A)	
Isc max.	kA rms
Making capacity	kA peak

##### By 690 V fuse

Type aM <sup>(2)</sup> /maximum rating (A)	
Isc max.	kA rms
Making capacity	kA peak
Type gG <sup>(3)</sup> /maximum rating (A)	
Isc max.	kA rms
Making capacity	kA peak
Type gG <sup>(2)</sup> /maximum rating (A)	
Isc max.	kA rms
Making capacity	kA peak

(2) Protection by external thermal relay obligatory.

(3) Without external thermal relay.



# Protection of switch-disconnectors

## INS40 to INS160 by Compact NSX circuit breaker

INS40	INS63	INS80	INS100	INS125	INS160
-	-	-	NSX100B/100 6 9	-	-
-	-	-	NSX100F/100 8 14	-	-
-	-	-	NSX100N/100 10 17	-	-
-	-	-	NSX100H/S/L/100 10 17	-	-
-	-	-	NSX160B/100 6 9	NSX160B/125 6 9	NSX160B/160 6 9
-	-	-	NSX160F/100 8 14	NSX160F/125 8 14	NSX160F/160 8 14
-	-	-	NSX160N/100 10 17	NSX160N/125 10 17	NSX160N/160 10 17
-	-	-	NSX160H/S/L/100 10 17	NSX160H/S/L/125 10 17	NSX160H/S/L/160 10 17
-	-	-	NSX250B/100 6 9	NSX250B/125 6 9	NSX250B/160 6 9
-	-	-	NSX250F/100 8 14	NSX250F/125 8 14	NSX250F/160 8 14
-	-	-	NSX250N/100 10 17	NSX250N/125 10 17	NSX250N/160 10 17
-	-	-	NSX250H/S/L/100 10 17	NSX250H/S/L/125 10 17	NSX250H/S/L/160 10 17
NSC100N/40 18 37	NSC100N/63 18 37	NSC100N/80 18 37	NSC100N/100 18 37	-	-
125 100 220	125 100 220	125 100 220	200 100 220	200 100 220	200 100 220
32 100 120	50 100 120	50 100 120	80 100 220	100 100 220	125 100 220
100 100 220	100 100 220	100 100 220	125/160 100/50 220/105	125/160 100/50 220/105	125/160 100/50 220/105
32 80 176	50 and 32M50 80 176	63 and 32M63 80 176	80 and 63M80 80 176	100 and 63M100 80 176	125 and 100M125 80 176
125 and 100M125 80 176	125 and 100M125 80 176	125 and 100M125 80 176	160 and 100M160 80 176	160 and 100M160 80 176	160 and 100M160 80 176
-	-	-	-	-	-
-	-	-	-	-	-
-	-	-	-	-	-

# Protection of switch-disconnectors

## INS/INV100 to INS/INV630 by Compact NSX circuit breaker

DB115220

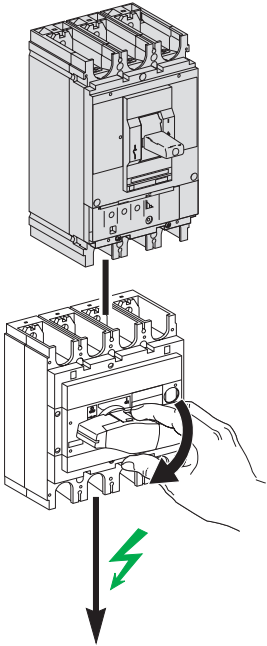

Interpact INS switch-disconnectors		INS250-100 / INV100	INS250-160 / INV160
<b>Upstream protection</b>			
<b>By Compact NSX</b>			
<b>By circuit breaker 380/415 V</b>			
Type/maximum rating (A)		NSX100-160-250B/100	NSX160-250B/160
Isc max.	kA rms	25	25
Making capacity	kA peak	52	52
Type/maximum rating (A)		NSX100-160-250F/100	NSX160-250F/160
Isc max.	kA rms	36	36
Making capacity	kA peak	75	75
Type/maximum rating (A)		NSX100-160-250N/100	NSX160-250N/160
Isc max.	kA rms	50	50
Making capacity	kA peak	105	105
Type/maximum rating (A)		NSX100-160-250H/100	NSX160-250H/160
Isc max.	kA rms	70	70
Making capacity	kA peak	154	154
Type/maximum rating (A)		NSX100-160-250S/100	NSX160-250S/160
Isc max.	kA rms	100	100
Making capacity	kA peak	120	120
Type/maximum rating (A)		NSX100-160-250L/100	NSX160-250L/160
Isc max.	kA rms	150	150
Making capacity	kA peak	330	330
<b>By circuit breaker 440/480 V <sup>(1)</sup></b>			
Type/maximum rating (A)		NSX100-160-250B/100	NSX160-250B/160
Isc max.	kA rms	20	20
Making capacity	kA peak	40	40
Type/maximum rating (A)		NSX100-160-250F/100	NSX160-250F/160
Isc max.	kA rms	35	35
Making capacity	kA peak	73	73
Type/maximum rating (A)		NSX100-160-250N/100	NSX160-250N/160
Isc max.	kA rms	50	50
Making capacity	kA peak	105	105
Type/maximum rating (A)		NSX100-160-250H/100	NSX160-250H/160
Isc max.	kA rms	65	65
Making capacity	kA peak	143	143
Type/maximum rating (A)		NSX100-160-250S/100	NSX160-250S/160
Isc max.	kA rms	90	90
Making capacity	kA peak	198	198
Type/maximum rating (A)		NSX100-160-250L/100	NSX160-250L/160
Isc max.	kA rms	130	130
Making capacity	kA peak	286	286
<b>By circuit breaker 500 V</b>			
Type/maximum rating (A)		NSX100-160-250B/100	NSX160-250B/160
Isc max.	kA rms	15	15
Making capacity	kA peak	30	30
Type/maximum rating (A)		NSX100F/100	-
Isc max.	kA rms	25	-
Making capacity	kA peak	52	-
Type/maximum rating (A)		NSX160-250F/100	NSX160-250H/160
Isc max.	kA rms	30	30
Making capacity	kA peak	63	63
Type/maximum rating (A)		NSX100-160-250N/100	NSX160-250N/160
Isc max.	kA rms	36	36
Making capacity	kA peak	75	75
Type/maximum rating (A)		NSX100-160-250H/100	NSX160-250H/160
Isc max.	kA rms	50	50
Making capacity	kA peak	105	105
Type/maximum rating (A)		NSX100-160-250S/100	NSX160-250S/160
Isc max.	kA rms	65	65
Making capacity	kA peak	143	143
Type/maximum rating (A)		NSX100-160-250L/100	NSX160-250L/160
Isc max.	kA rms	70	70
Making capacity	kA peak	154	154

<sup>(1)</sup> Applicable for 480 NEMA.

# Protection of switch-disconnectors

## INS/INV100 to INS/INV630 by Compact NSX circuit breaker

	INS250-200 / INV200	INS/INV250	INS/INV320	INS/INV400	INS/INV500	INS/INV630
	NSX250B/200 25 52	NSX250N/250 25 52	-	-	-	-
	NSX250F/200 36 75	NSX250F/250 36 75	NSX400-630F/320 36 75	NSX400-630F/400 36 75	NSX630F/500 36 75	NSX630F/630 36 75
	NSX250N/200 50 105	NSX250N/250 50 105	NSX400-630N/320 50 105	NSX400-630N/400 50 105	NSX630N/500 50 105	NSX630N/630 50 105
	NSX250H/200 70 154	NSX250H/250 70 154	NSX400-630H/320 70 154	NSX400-630H/400 70 154	NSX630H/500 70 154	NSX630H/630 70 154
	NSX250S/200 100 120	NSX250S/250 100 120	NSX400-630S/320 100 120	NSX400-630S/400 100 120	NSX630S/500 100 120	NSX630S/630 100 120
	NSX250L/200 150 330	NSX250L/250 150 330	NSX400-630L/320 150 330	NSX400-630L/400 150 330	NSX630L/500 150 330	NSX630L/630 150 330
	NSX250B/200 20 40	NSX250B/250 20 40	-	-	-	-
	NSX250F/200 35 73	NSX250F/250 35 73	NSX400-630F/320 35 73	NSX400-630F/400 35 73	NSX630F/500 35 73	NSX630F/630 35 73
	NSX250N/200 50 105	NSX250N/250 50 105	NSX400-630N/320 50 105	NSX400-630N/400 50 105	NSX630N/500 50 105	NSX630N/630 50 105
	NSX250H/200 65 143	NSX250H/250 65 143	NSX400-630H/320 65 143	NSX400-630H/400 65 143	NSX630H/500 65 143	NSX630H/630 65 143
	NSX250S/200 90 198	NSX250S/250 90 198	NSX400-630S/320 90 198	NSX400-630S/400 90 198	NSX630S/500 90 198	NSX630S/630 90 198
	NSX250L/200 130 286	NSX250L/250 130 286	NSX400-630L/320 130 286	NSX400-630L/400 130 286	NSX630L/500 130 286	NSX630L/630 130 286
	NSX250B/200 15 30	NSX250B/250 15 30	-	-	-	-
	-	-	-	-	-	-
	NSX250F/200 30 63	NSX250F/250 30 63	NSX400-630F/320 25 52	NSX400-630F/400 25 52	NSX630F/500 25 52	NSX630F/630 25 52
	NSX250N/200 36 75	NSX250N/250 36 75	NSX400-630N/320 30 63	NSX400-630N/400 30 63	NSX630N/500 30 63	NSX630N/630 30 63
	NSX250H/200 50 105	NSX250H/250 50 105	NSX400-630H/320 50 105	NSX400-630H/400 50 105	NSX630H/500 50 105	NSX630H/630 50 105
	NSX250S/200 65 143	NSX250S/250 65 143	NSX400-630S/320 65 143	NSX400-630S/400 65 143	NSX630S/500 65 143	NSX630S/630 65 143
	NSX250L/200 70 154	NSX250L/250 70 154	NSX400-630L/320 70 154	NSX400-630L/400 70 154	NSX630L/500 70 154	NSX630L/630 70 154

# Protection of switch-disconnectors

## INS/INV100 to INS/INV630 by Compact NSX circuit breaker

DB115220

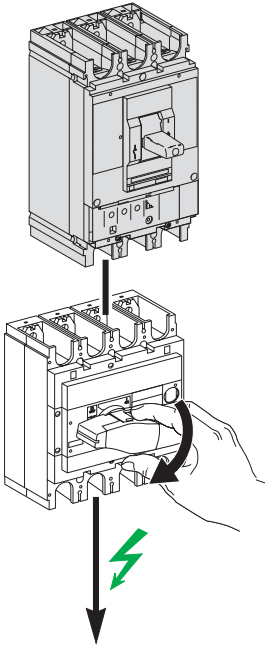

Interpact INS switch-disconnectors		INS250-100 / INV100	INS250-160 / INV160
<b>Upstream protection</b>			
<b>By Compact NSX</b>			
<b>By circuit breaker 525 V</b>			
Type/maximum rating (A)		NSX100-160-250B/100	NSX160-250B/160
Isc max.	kA rms	12	12
Making capacity	kA peak	24	24
Type/maximum rating (A)		NSX100-160-250F/100	NSX160-250F/160
Isc max.	kA rms	22	22
Making capacity	kA peak	47	47
Type/maximum rating (A)		NSX100-160-250N/100	NSX160-250N/160
Isc max.	kA rms	35	35
Making capacity	kA peak	73	73
Type/maximum rating (A)		NSX100-160-250H/100	NSX160-250H/160
Isc max.	kA rms	35	35
Making capacity	kA peak	73	73
Type/maximum rating (A)		NSX100-160-250S/100	NSX160-250S/160
Isc max.	kA rms	40	40
Making capacity	kA peak	81	81
Type/maximum rating (A)		NSX100-160-250L/100	NSX160-250L/160
Isc max.	kA rms	50	50
Making capacity	kA peak	105	105
<b>By circuit breaker 690 V</b>			
Type/maximum rating (A)		NSX100-160-250B/100	NSX160-250B/160
Isc max.	kA rms	6	6
Making capacity	kA peak	9	9
Type/maximum rating (A)		NSX100-160-250F/100	NSX160-250F/160
Isc max.	kA rms	8	8
Making capacity	kA peak	14	14
Type/maximum rating (A)		NSX100-160-250N/100	NSX160-250N/160
Isc max.	kA rms	10	10
Making capacity	kA peak	17	17
Type/maximum rating (A)		NSX100-160-250H/100	NSX160-250H/160
Isc max.	kA rms	10	10
Making capacity	kA peak	17	17
Type/maximum rating (A)		NSX100-160-250S/100	NSX160-250S/160
Isc max.	kA rms	15	15
Making capacity	kA peak	30	30
Type/maximum rating (A)		NSX100-160-250L/100	NSX160-250L/160
Isc max.	kA rms	20	20
Making capacity	kA peak	40	40
<b>Upstream protection by fuse</b>			
<b>By 500 V fuse</b>			
Type aM <sup>(2)</sup> /maximum rating (A)		315	315
Isc max.	kA rms	100	100
Making capacity	kA peak	220	220
Type gG <sup>(3)</sup> /maximum rating (A)		80	125
Isc max.	kA rms	100	100
Making capacity	kA peak	220	220
Type gG <sup>(2)</sup> /maximum rating (A)		225/355	225/355
Isc max.	kA rms	100/50	100/50
Making capacity	kA peak	220/105	220/105
Type BS <sup>(3)</sup> /maximum rating (A)		80 and 63M80	125 and 100M125
Isc max.	kA rms	80	80
Making capacity	kA peak	176	176
Type BS <sup>(2)</sup> /maximum rating (A)		250 and 200M250	250 and 200M250
Isc max.	kA rms	80	80
Making capacity	kA peak	176	176
<b>By 690 V fuse</b>			
Type aM <sup>(2)</sup> /maximum rating (A)		-	-
Isc max.	kA rms	-	-
Making capacity	kA peak	-	-
Type gG <sup>(3)</sup> /maximum rating (A)		-	-
Isc max.	kA rms	-	-
Making capacity	kA peak	-	-
Type gG <sup>(2)</sup> /maximum rating (A)		-	-
Isc max.	kA rms	-	-
Making capacity	kA peak	-	-

<sup>(2)</sup> Protection by external thermal relay obligatory.

<sup>(3)</sup> Without external thermal relay.

# Protection of switch-disconnectors

## INS/INV100 to INS/INV630 by Compact NSX circuit breaker

	INS250-200 / INV200	INS/INV250	INS/INV320	INS/INV400	INS/INV500	INS/INV630
	NSX250B/200 12 24	NSX250B/250 12 24	-	-	-	-
	NSX250F/200 22 47	NSX250F/250 22 47	NSX400-630F/320 22 47	NSX400-630F/400 22 47	NSX630F/500 22 47	NSX630F/630 22 47
	NSX250N/200 35 73	NSX250N/250 35 73	NSX400-630N/320 22 47	NSX400-630N/400 22 47	NSX630N/500 22 47	NSX630N/630 22 47
	NSX250H/200 35 73	NSX250H/250 35 73	NSX400-630H/320 35 73	NSX400-630H/400 35 73	NSX630H/500 35 73	NSX630H/630 35 73
	NSX250S/200 40 81	NSX250S/250 40 81	NSX400-630S/320 40 81	NSX400-630S/400 40 81	NSX630S/500 40 81	NSX630S/630 40 81
	NSX250L/200 50 105	NSX250L/250 50 105	NSX400-630L/320 50 105	NSX400-630L/400 50 105	NSX630L/500 50 105	NSX630L/630 50 105
	NSX250B/200 6 9	NSX250B/250 6 9	-	-	-	-
	NSX250F/200 8 14	NSX250F/250 8 14	NSX400-630F/320 8 14	NSX400-630F/400 8 14	NSX630F/500 8 14	NSX630F/630 8 14
	NSX250N/200 10 17	NSX250N/250 10 17	NSX400-630N/320 10 17	NSX400-630N/400 10 17	NSX630N/500 10 17	NSX630N/630 10 17
	NSX250H/200 10 17	NSX250H/250 10 17	NSX400-630H/320 10 17	NSX400-630H/400 10 17	NSX630H/500 10 17	NSX630H/630 10 17
	NSX250S/200 15 30	NSX250S/250 15 30	NSX400-630S/320 15 30	NSX400-630S/400 15 30	NSX630S/500 15 30	NSX630S/630 15 30
	NSX250L/200 20 40	NSX250L/250 20 40	NSX400-630L/320 20 40	NSX400-630L/400 20 40	NSX630L/500 20 40	NSX630L/630 20 40
	315 100 220	315 100 220	800 100 220	800 100 220	800 100 220	800 100 220
	160 100 220	200 100 220	250 100 220	315 100 220	400 100 220	500 100 220
	225/355 100/50 220/105	225/355 100/50 220/105	630 50 105	630 50 105	630 50 105	500/630 100/50 220/105
	160 and 100M160 80 176	200 and 100M200 80 176	250 and 200M250 80 176	315 and 200M250 80 176	400 80 176	450 and 400M450 80 176
	250 and 200M250 80 176	250 and 200M250 80 176	355 and 315M355 80 176	355 and 315M355 80 176	450 and 400M450 80 176	450 and 400M450 80 176
	-	-	-	800 100 220	800 100 220	800 100 220
	-	-	-	315 100 220	400 100 220	500 100 220
	-	-	-	630 50 105	630 50 105	500/630 100/50 220/105

# Protection of switch-disconnectors

## INS40 to INS160 by Compact NS circuit breaker

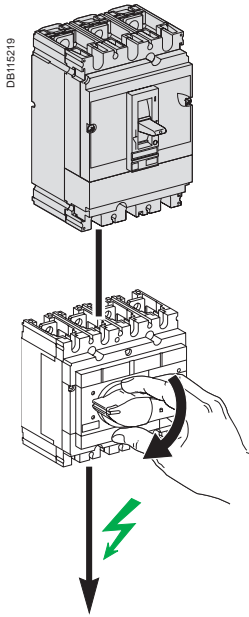

### Interpact INS switch-disconnectors

#### Upstream protection

##### By Compact NS circuit breaker

<b>By circuit breaker 380/415 V</b>	Type/maximum rating (A)	
	Isc max.	kA rms
	Making capacity	kA peak
	Type/maximum rating (A)	
	Isc max.	kA rms
	Making capacity	kA peak
	Type/maximum rating (A)	
	Isc max.	kA rms
	Making capacity	kA peak
	Type/maximum rating (A)	
	Isc max.	kA rms
	Making capacity	kA peak
<b>By circuit breaker 440/480 V <sup>(1)</sup></b>	Type/maximum rating (A)	
	Isc max.	kA rms
	Making capacity	kA peak
	Type/maximum rating (A)	
	Isc max.	kA rms
	Making capacity	kA peak
	Type/maximum rating (A)	
	Isc max.	kA rms
	Making capacity	kA peak
	Type/maximum rating (A)	
	Isc max.	kA rms
	Making capacity	kA peak
<b>By circuit breaker 500 V (INS40 to INS80)</b>	Type/maximum rating (A)	
	Isc max.	kA rms
	Making capacity	kA peak
	Type/maximum rating (A)	
	Isc max.	kA rms
	Making capacity	kA peak
	Type/maximum rating (A)	
	Isc max.	kA rms
	Making capacity	kA peak
	Type/maximum rating (A)	
	Isc max.	kA rms
	Making capacity	kA peak
<b>500/525 V (INS100 to INS160)</b>	Type/maximum rating (A)	
	Isc max.	kA rms
	Making capacity	kA peak
	Type/maximum rating (A)	
	Isc max.	kA rms
	Making capacity	kA peak
	Type/maximum rating (A)	
	Isc max.	kA rms
	Making capacity	kA peak
	Type/maximum rating (A)	
	Isc max.	kA rms
	Making capacity	kA peak
<b>By circuit breaker 690 V</b>	Type/maximum rating (A)	
	Isc max.	kA rms
	Making capacity	kA peak
	Type/maximum rating (A)	
	Isc max.	kA rms
	Making capacity	kA peak
Type/maximum rating (A)		
Isc max.	kA rms	
Making capacity	kA peak	
Type/maximum rating (A)		
Isc max.	kA rms	
Making capacity	kA peak	

<sup>(1)</sup> Applicable for 480 NEMA.

# Protection of switch-disconnectors

## INS40 to INS160 by Compact NS circuit breaker

	INS40	INS63	INS80	INS100	INS125	INS160
	NS100N/40 36 75	NS100N/63 36 75	NS100N/80 36 75	NS100N/100 36 75	-	-
	NS100SX-H-L/40 36 75	NS100SX-H-L/63 36 75	NS100SX-H-L/80 36 75	NS100SX-H-L/100 50/70 105/54	-	-
	NS160N-SX/40 25 52	NS160N-SX/63 25 52	NS160N-SX/80 25 52	NS160-250N/100 36 75	NS160-250N/125 36 75	NS160-250N/160 36 75
	NS160H-L/40 25 52	NS160H-L/63 25 52	NS160H-L/80 25 52	NS160-250SX-H-L/100 50/70 105/154	NS160-250SX-H-L/125 50/70 105/154	NS160-250SX-H-L/160 50/70 105/154
	NSC100N/40 18 37	NSC100N/63 18 37	NSC100N/80 18 37	NSC100N/100 18 37	-	-
	NG125N/40 25 52	NG125N/63 25 52	NG125N/80 25 52	NG125N/100 25 52	NG125N/125 25 52	-
	NG125H/40 36 75	NG125H/63 36 75	NG125H/80 36 75	-	-	-
	NG125L/40 50 105	NG125L/63 50 105	NG125L/80 50 105	-	-	-
	NSA160N/40 30 63	NSA160N/63 30 63	NSA160N/80 30 63	NSA160N/100 30 63	NSA160N/125 30 63	NSA160N/160 30 63
	NS100N/40 35 73	NS100N/63 35 73	NS100N/80 35 73	NS100N/100 35 73	-	-
	NS100SX-H-L/40 35 73	NS100SX-H-L/63 35 73	NS100SX-H-L/80 35 73	NS100SX-H-L/100 35/65 73/143	-	-
	NS160N/40 25 52	NS160N/63 25 52	NS160N/80 25 52	NS160-250N/100 35 73	NS160-250N/125 35 73	NS160-250N/160 35 73
	NS160H-L/40 25 52	NS160H-L/63 25 52	NS160H-L/80 25 52	NS160-250SX-H-L/100 35/65 73/143	NS160-250SX-H-L/125 35/65 73/143	NS160-250SX-H-L/160 35/65 73/143
	NSC100N/40 18 37	NSC100N/63 18 37	NSC100N/80 18 37	NSC100N/100 18 37	-	-
	NS100N/40 18 36	NS100N/63 18 36	NS100N/80 18 36	NS100N/100 18 36	-	-
	NS100SX-H-L/40 18-25 36-53	NS100SX-H-L/63 18-25 36-53	NS100SX-H-L/80 18-25 36-53	NS100SX-H-L/100 35-100 73-220	-	-
	NS160N/40 15 30	NS160N/63 15 30	NS160N/80 15 30	NS160-250N/100 22 46	NS160-250N/125 22 46	NS160-250N/160 22 46
	NS160SX-H-L/40 15 30	NS160SX-H-L/63 15 30	NS160SX-H-L/80 15 30	NS160-250SX-H-L/100 22 46	NS160-250SX-H-L/125 22 46	NS160-250SX-H-L/160 22 46
	NSC100N/40 10 17	NSC100N/63 10 17	NSC100N/80 10 17	NSC100N/100 10 17	-	-
	-	-	-	NS100N/100 8 14	-	-
	-	-	-	NS100SX-H-L/100 10-75 17-165	-	-
	-	-	-	NS160-250N/100 8 14	NS160-250N/125 8 14	NS160-250N/160 8 14
	-	-	-	NS160-250SX-H-L/100 10-20 17-40	NS160-250SX-H-L/125 10-20 17-40	NS160-250SX-H-L/160 10-20 17-40

# Protection of switch-disconnectors INS/INV100 to INS/INV630 by Compact NS circuit breaker

DE115220

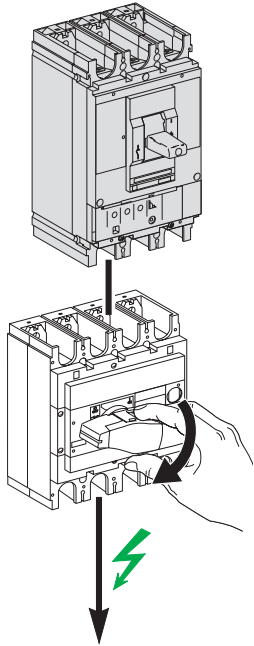

Interpact INS switch-disconnectors		INS250-100 / INV100	INS250-160 / INV160
Upstream protection			
By Compact NS circuit breaker			
<b>By circuit breaker 380/415 V</b>	Type/maximum rating (A)	NS100-160-250N/100	NS160-250N/160
	Isc max.	36	36
	Making capacity	75	75
	Type/maximum rating (A)	NS100-160-250SX/100	NS160-250SX/160
	Isc max.	50	50
	Making capacity	105	105
	Type/maximum rating (A)	NS100-160-250H/100	NS160-250H/160
	Isc max.	70	70
	Making capacity	154	154
<b>By circuit breaker 440/480 V <sup>(1)</sup></b>	Type/maximum rating (A)	NS100-160-250L/100	NS160-250L/160
	Isc max.	150	150
	Making capacity	330	330
	Type/maximum rating (A)	NS100-160-250N/100	NS160-250N/160
	Isc max.	35	35
	Making capacity	73	73
	Type/maximum rating (A)	NS100-160-250SX	NS160-250SX
	Isc max.	50	50
	Making capacity	105	105
<b>By circuit breaker 500 V</b>	Type/maximum rating (A)	NS100-160-250H/100	NS160-250H/160
	Isc max.	65	65
	Making capacity	143	143
	Type/maximum rating (A)	NS100-160-250L/100	NS160-250L/160
	Isc max.	130	130
	Making capacity	286	286
	Type/maximum rating (A)	NS100-160-250N/100	NS160-250N/160
	Isc max.	25-30-30	30
	Making capacity	53-63-63	63
<b>By circuit breaker 525 V</b>	Type/maximum rating (A)	NS100-160-250SX/100	NS160-250SX/160
	Isc max.	36	36
	Making capacity	75	75
	Type/maximum rating (A)	NS100-160-250H/100	NS160-250H/160
	Isc max.	50	50
	Making capacity	105	105
	Type/maximum rating (A)	NS100-160-250L/100	NS160-250L/160
	Isc max.	100-70-70	70
	Making capacity	220-154-154	154
<b>By circuit breaker 690 V</b>	Type/maximum rating (A)	NS100-160-250N/100	NS160-250N/160
	Isc max.	22	22
	Making capacity	46	46
	Type/maximum rating (A)	NS100-160-250SX/100	NS160-250SX/160
	Isc max.	35	35
	Making capacity	73	73
	Type/maximum rating (A)	NS100-160-250H/100	NS160-250H/160
	Isc max.	35	35
	Making capacity	73	73
<b>By circuit breaker 690 V</b>	Type/maximum rating (A)	NS100-160-250L/100	NS160-250L/160
	Isc max.	100-50-50	50
	Making capacity	220-105-105	105
	Type/maximum rating (A)	NS100-160-250N/100	NS160-250N/160
	Isc max.	8	8
	Making capacity	14	14
	Type/maximum rating (A)	NS100-160-250SX/100	NS160-250SX/160
	Isc max.	10	10
	Making capacity	17	17
<b>By circuit breaker 690 V</b>	Type/maximum rating (A)	NS100-160-250H/100	NS160-250H/160
	Isc max.	10	10
	Making capacity	17	17
	Type/maximum rating (A)	NS100-160-250L/100	NS160-250L/160
	Isc max.	75-20-20	20
	Making capacity	165-40-40	40

(1) Applicable for 480 NEMA.



# Protection of switch-disconnectors

## INS/INV100 to INS/INV630

### by Compact NS circuit breaker

	INS250-200 / INV200	INS/INV250	INS/INV320	INS/INV400	INS/INV500	INS/INV630
	NS250N/200 36 75	NS250N/250 36 75	NS400-630N/320 50 105	NS400-630N/400 50 105	NS630N/500 50 105	NS630N/630 50 105
	NS250SX/200 50 105	NS250SX/250 50 105	-	-	-	-
	NS250H/200 70 154	NS250H/250 70 154	NS400-630H/320 70 154	NS400-630H/400 70 154	NS630H/500 70 154	NS630H/630 70 154
	NS250L/200 150 330	NS250L/250 150 330	NS400-630L/320 150 330	NS400-630L/400 150 330	NS630L/500 150 330	NS630L/630 150 330
	NS250N/200 35 73	NS250N/250 35 73	NS400-630N/320 42 88	NS400-630N/400 42 88	NS630N/500 42 88	NS630N/630 42 88
	NS250SX/200 50 105	NS250SX/250 50 105	-	-	-	-
	NS250H/200 65 143	NS250H/250 65 143	NS400-630H/320 65 143	NS400-630H/400 65 143	NS630H/500 65 143	NS630H/630 65 143
	NS250L/200 130 286	NS250L/250 130 286	NS400-630L/320 130 286	NS400-630L/400 130 286	NS630L/500 130 286	NS630L/630 130 286
	NS250N/200 30 63	NS250N/250 30 63	NS400-630N/320 30 63	NS400-630N/400 30 63	NS630N/500 30 63	NS630N/630 30 63
	NS250SX/200 36 75	NS250SX/250 36 75	-	-	-	-
	NS250H/200 50 105	NS250H/250 50 105	NS400-630H/320 50 105	NS400-630H/400 50 105	NS630H/500 50 105	NS630H/630 50 105
	NS250L/200 70 154	NS250L/250 70 154	NS400-630L/320 100-70 220-154	NS400-630L/400 100-70 220-154	NS630L/500 70 154	NS630L/630 70 154
	NS250N/200 22 46	NS250N/250 22 46	NS400-630N/320 22 46	NS400-630N/400 22 46	NS630N/500 22 46	NS630N/630 22 46
	NS250SX/200 35 73	NS250SX/250 35 73	-	-	-	-
	NS250H/200 35 73	NS250H/250 35 73	NS400-630H/320 35 73	NS400-630H/400 35 73	NS630H/500 35 73	NS630H/630 35 73
	NS250L/200 50 105	NS250L/250 50 105	NS400-630L/320 100-50 220-105	NS400-630L/400 100-50 220-105	NS630L/500 50 105	NS630L/630 50 105
	NS250N/200 8 14	NS250N/250 8 14	NS400-630N/320 10 17	NS400-630N/400 10 17	NS630N/500 10 17	NS630N/630 10 17
	NS250SX/200 10 17	NS250SX/250 10 17	-	-	-	-
	NS250H/200 10 17	NS250H/250 10 17	NS400-630H/320 20 40	NS400-630H/400 20 40	NS630H/500 20 42	NS630H/630 20 42
	NS250L/200 20 40	NS250L/250 20 40	NS400-630L/320 75-35 165-73	NS400-630L/400 75-35 165-73	NS630L/500 35 73	NS630L/630 35 73

# Protection of switch-disconnectors

## INS/INV630b to INS/INV2500

### by Compact NS circuit breaker

DE115221

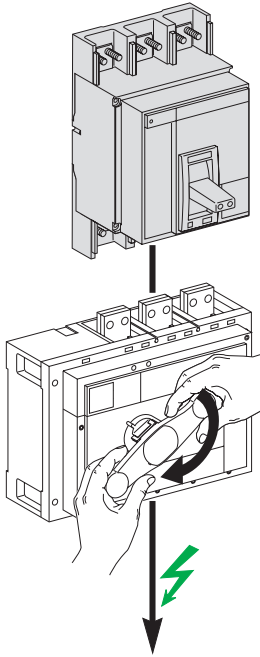

#### Interpact INS switch-disconnectors

##### Upstream protection

###### By Compact NS circuit breaker

<b>By circuit breaker 380/415 V</b>	Type/maximum rating (A)	
	Isc max.	kA rms
	Making capacity	kA peak
	Type/maximum rating (A)	
	Isc max.	kA rms
	Making capacity	kA peak
<b>By circuit breaker 440/480 V <sup>(1)</sup></b>	Type/maximum rating (A)	
	Isc max.	kA rms
	Making capacity	kA peak
	Type/maximum rating (A)	
	Isc max.	kA rms
	Making capacity	kA peak
<b>By circuit breaker 500/525 V</b>	Type/maximum rating (A)	
	Isc max.	kA rms
	Making capacity	kA peak
	Type/maximum rating (A)	
	Isc max.	kA rms
	Making capacity	kA peak
<b>By circuit breaker 690 V</b>	Type/maximum rating (A)	
	Isc max.	kA rms
	Making capacity	kA peak
	Type/maximum rating (A)	
	Isc max.	kA rms
	Making capacity	kA peak
<b>By Masterpact NT H1 circuit breaker</b>		
<b>By circuit breaker 220/690 V</b>	Type/maximum rating (A)	
	Isc max.	kA rms
	Making capacity	kA peak
<b>By Masterpact NT H2 circuit breaker</b>		
<b>By circuit breaker 220/690 V</b>	Type/maximum rating (A)	
	Isc max.	kA rms
	Making capacity	kA peak
<b>By Masterpact NT L1 circuit breaker</b>		
<b>By circuit breaker 220/525 V</b>	Type/maximum rating (A)	
	Isc max.	kA rms
	Making capacity	kA peak
<b>By circuit breaker 690 V</b>	Type/maximum rating (A)	
	Isc max.	kA rms
	Making capacity	kA peak

<sup>(1)</sup> Applicable for 480 NEMA.

# Protection of switch-disconnectors

## INS/INV630b to INS/INV2500

### by Compact NS circuit breaker

	INS/INV630b	INS/INV800	INS/INV1000	INS/INV1250	INS/INV1600	INS/INV2000	INS/INV2500
	NS630bN/630 35 75	NS800N/800 35 75	NS1000N/1000 35 75	NS1250N/1250 35 75	NS1600N - NS1600bN/1600 35 75	NS2000N/2000 50 105	NS2500N/2500 50 105
	NS630bH/630 35 75	NS800H/800 35 75	NS1000H/1000 35 75	NS1250H/1250 35 75	NS1600H - NS1600bH/1600 35 75	NS2000H/2000 50 105	NS2500H/2500 50 105
	NS630bL/630 150 330	NS800L/800 150 330	NS1000L/1000 150 330	-	-	-	-
	NS630bN/630 35 75	NS800N/800 35 75	NS1000N/1000 35 75	NS1250N/1250 35 75	NS1600N - NS1600bN/1600 35 75	NS2000N/2000 50 105	NS2500N/2500 50 105
	NS630bH/630 35 75	NS800H/800 35 75	NS1000H/1000 35 75	NS1250H/1250 35 75	NS1600H - NS1600bH/1600 35 75	NS2000H/2000 50 105	NS2500H/2500 50 105
	NS630bL/630 130 286	NS800L/800 130 286	NS1000L/1000 130 286	-	-	-	-
	NS630bN/630 35 75	NS800N/800 35 75	NS1000N/1000 35 75	NS1250N/1250 35 75	NS1600N - NS1600bN/1600 35 75	NS2000N/2000 50 105	NS2500N/2500 50 105
	NS630bH/630 35 75	NS800H/800 35 75	NS1000H/1000 35 75	NS1250H/1250 35 75	NS1600H - NS1600bH/1600 35 75	NS2000H/2000 50 105	NS2500H/2500 50 105
	NS630bL/630 100 220	NS800L/800 100 220	NS1000L/1000 100 220	-	-	-	-
	NS630bN/630 30 63	NS800N/800 30 63	NS1000N/1000 30 63	NS1250N/1250 30 63	NS1600bN/1600 30 63	NS2000N/2000 50 105	NS2500N/2500 50 105
	NS630bH/630 35 75	NS800H/800 35 75	NS1000H/1000 35 75	NS1250H/1250 35 75	NS1600bH/1600 35 75	NS2000H/2000 50 105	NS2500H/2500 50 105
	NS630bL/630 25 53	NS800L/800 25 53	NS1000L/1000 25 53	-	-	-	-
	NT06H1/630 35 75	NT08H1/800 35 75	NT10H1/1000 35 75	NT12H1/1250 35 75	NT16H1/1600 35 75	-	-
	NT06H2/630 35 75	NT08H2/800 35 75	NT10H2/1000 35 75	NT12H2/1250 35 75	NT16H2/1600 35 75	-	-
	NT06L1/630 100 220	NT08L1/800 100 220	NT10L1/1000 100 220	NT12L1/1250 100 220	NT16L1/1600 100 220	-	-
	NT06L1/630 25 53	NT08L1/800 25 53	NT10L1/1000 25 53	NT12L1/1250 25 53	NT16L1/1600 25 53	-	-

# Protection of switch-disconnectors

## INS/INV630b to INS/INV2500

### by Masterpact NT and NW circuit breakers

DE115222

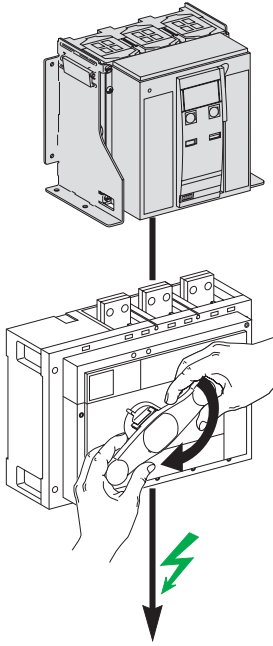

#### Interpact INS switch-disconnectors

##### Upstream protection

##### By Masterpact NW N1- H1- H2- H3 circuit breaker

<b>By circuit breaker</b> <b>220/440-480 V<sup>(1)</sup></b>	Type/maximum rating (A)		
	Isc max.	kA rms	
	Making capacity	kA peak	
	Type/maximum rating (A)		
	Isc max.	kA rms	
	Making capacity	kA peak	
	Type/maximum rating (A)		
	Isc max.	kA rms	
	Making capacity	kA peak	
<b>By circuit breaker</b> <b>500/525 V</b>	Type/maximum rating (A)		
	Isc max.	kA rms	
	Making capacity	kA peak	
	Type/maximum rating (A)		
	Isc max.	kA rms	
	Making capacity	kA peak	
	Type/maximum rating (A)		
	Isc max.	kA rms	
	Making capacity	kA peak	
<b>By circuit breaker</b> <b>690 V</b>	Type/maximum rating (A)		
	Isc max.	kA rms	
	Making capacity	kA peak	
	Type/maximum rating (A)		
	Isc max.	kA rms	DIN OFF / DIN ON
	Making capacity	kA peak	DIN OFF / DIN ON
	Type/maximum rating (A)		
	Isc max.	kA rms	DIN OFF / DIN ON
	Making capacity	kA peak	DIN OFF / DIN ON
<b>By Masterpact NW L1 circuit breaker</b>			
<b>By circuit breaker</b> <b>220/690 V</b>	Type/maximum rating (A)		
	Isc max.	kA rms	
	Making capacity	kA peak	
<b>By fuse</b> <b>By fuse 500 V</b>	Type aM <sup>(2)</sup> / max. rating (A)		
	Isc max.	kA rms	
	Making capacity	kA peak	
	Type gG <sup>(3)</sup> / max. ra ing (A)		
	Isc max.	kA rms	
	Making capacity	kA peak	
	Type gG <sup>(2)</sup> / max. rating (A)		
	Isc max.	kA rms	
	Making capacity	kA peak	
	Type BS <sup>(3)</sup> / max. rating (A)		
	Isc max.	kA rms	
	Making capacity	kA peak	
	Type BS <sup>(2)</sup> / max. ra ing (A)		
	Isc max.	kA rms	
	Making capacity	kA peak	
<b>By fuse 690 V</b>	Type aM <sup>(2)</sup> / max. rating (A)		
	Isc max.	kA rms	
	Making capacity	kA peak	
	Type gG <sup>(3)</sup> / max. ra ing (A)		
	Isc max.	kA rms	
	Making capacity	kA peak	
	Type gG <sup>(2)</sup> / max. ra ing (A)		
	Isc max.	kA rms	
	Making capacity	kA peak	

(1) Applicable for 480 NEMA.

(2) Mandatory protection by an external thermal relay.

(3) No external thermal relay.

# Protection of switch-disconnectors

## INS/INV630b to INS/INV2500

### by Masterpact NT and NW circuit breakers

	INS/INV630b	INS/INV800	INS/INV1000	INS/INV1250	INS/INV1600	INS/INV2000	INS/INV2500
	NW08N1/630 35 75	NW08N1/800 35 75	NW10N1/1000 35 75	NW12N1/1250 35 75	NW16N1/1600 35 75	-	-
	NW08H1/630 35 75	NW08H1/800 35 75	NW10H1/1000 35 75	NW12H1/1250 35 75	NW16H1/1600 35 75	NW20H1/2000 50 105	NW25H1/2500 50 105
	NW08H2/630 35 75	NW08H2/800 35 75	NW10H2/1000 35 75	NW12H2/1250 35 75	NW16H2/1600 35 75	NW20H2/2000 50 105	NW25H2/2500 50 105
	-	-	-	-	-	NW20H3/2000 50 105	NW25H3/2500 50 105
	NW08N1/630 35 75	NW08N1/800 35 75	NW10N1/1000 35 75	NW12N1/1250 35 75	NW16N1/1600 35 75	-	-
	NW08H1/630 35 75	NW08H1/800 35 75	NW10H1/1000 35 75	NW12H1/1250 35 75	NW16H1/1600 35 75	NW20H1/2000 50 105	NW25H1/2500 50 105
	NW08H2/630 35 75	NW08H2/800 35 75	NW10H2/1000 35 75	NW12H2/1250 35 75	NW16H2/1600 35 75	NW20H2/2000 50 105	NW25H2/2500 50 105
	-	-	-	-	-	NW20H3/2000 50 105	NW25H3/2500 50 105
	NW08N1/630 35 75	NW08N1/800 35 75	NW10N1/1000 35 75	NW12N1/1250 35 75	NW16N1/1600 35 75	-	-
	NW08H1/630 35 75	NW08H1/800 35 75	NW10H1/1000 35 75	NW12H1/1250 35 75	NW16H1/1600 35 75	NW20H1/2000 50 105	NW25H1/2500 50 105
	NW08H2/630 35 75	NW08H2/800 35 75	NW10H2/1000 35 75	NW12H2/1250 35 75	NW16H2/1600 35 75	NW20H2/2000 50 105	NW25H2/2500 50 105
	-	-	-	-	-	NW20H3/2000 50 105	NW25H3/2500 50 105
	NW08L1/630 35 75	NW08L1/800 35 75	NW10L1/1000 35 75	NW12L1/1250 35 75	NW16L1/1600 35 75	NW20L1/2000 50 105	-
	1000/1250 100 220 500	1000/1250 100 220 630	1000/1250 100 220 800	1000/1250 100 220 1000	1000/1250 100 220 1000/1250	-	-
	100 220	100 220	100 220	80 176	80/50 176/105	-	-
	1000/1250 80/50 176/105	1000/1250 80/50 176/105	1000/1250 80/50 176/105	1000/1250 80/50 176/105	1000/1250 80/50 176/105	-	-
	500 80 176	630 80 176	800 80 176	1000 80 176	1000/1250 80/50 176/105	-	-
	1000/1250 80/50 176/105	1000/1250 80/50 176/105	1000/1250 80/50 176/105	1000/1250 80/50 176/105	1000/1250 80/50 176/105	-	-
	1000/1250 100 220	1000/1250 100 220	1000/1250 100 220	1000/1250 100 220	1000/1250 100 220	-	-
	500 100 220	630 100 220	800 100 220	1000 80 176	1000/1250 80/50 176/105	-	-
	1000/1250 80/50 176/105	1000/1250 80/50 176/105	1000/1250 80/50 176/105	1000/1250 80/50 176/105	1000/1250 80/50 176/105	-	-

# Protection of switch-disconnectors

## INS40 to 2500 and INV100 to 2500 by fuses

DE115722

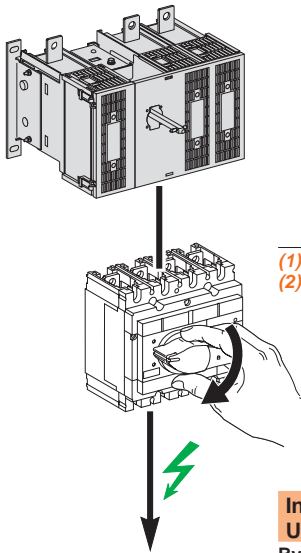

Interpact INS switch-disconnectors		INS40	INS63	INS80
<b>Upstream protection</b>				
<b>By fuse 500 V</b>	Type aM <sup>(1)</sup> / max. rating (A)	125	125	125
	Isc max. kA rms	100	100	100
	Making capacity kA peak	220	220	220
	Type gG <sup>(2)</sup> / max. rating (A)	32	50	63
	Isc max. kA rms	100	100	100
	Making capacity kA peak	220	220	220
	Type gG <sup>(1)</sup> / max. rating (A)	100	100	100
	Isc max. kA rms	100	100	100
	Making capacity kA peak	220	220	220
	Type BS <sup>(2)</sup> / max. rating (A)	32	50 & 32M50	63 & 32M63
	Isc max. kA rms	80	80	80
	Making capacity kA peak	176	176	176
Type BS <sup>(1)</sup> / max. rating (A)	125 & 100M125	125 & 100M125	125 & 100M125	
Isc max. kA rms	80	80	80	
Making capacity kA peak	176	176	176	

(1) Mandatory protection by an external thermal relay.  
 (2) No external thermal relay.

Interpact INS switch-disconnectors		INS/INV400	INS/INV500	INS/INV630	
<b>Upstream protection</b>					
<b>By fuse 500 V</b>	Type aM <sup>(1)</sup> / max. rating (A)	800	800	800	
	Isc max. kA rms	100	100	100	
	Making capacity kA peak	220	220	220	
	Type gG <sup>(2)</sup> / max. rating (A)	315	400	500	
	Isc max. kA rms	100	100	100	
	Making capacity kA peak	220	220	220	
	Type gG <sup>(1)</sup> / max. rating (A)	630	630	500/630	
	Isc max. kA rms	50	50	100/50	
	Making capacity kA peak	105	105	220/105	
	Type BS <sup>(2)</sup> / max. rating (A)	315 & 200M315	400	500	
	Isc max. kA rms	80	80	80	
	Making capacity kA peak	176	176	176	
	Type BS <sup>(1)</sup> / max. rating (A)	355 & 315M355	450 & 400M450	450 & 400M450	
	Isc max. kA rms	80	80	80	
	Making capacity kA peak	176	176	176	
	<b>By fuse 690 V</b>	Type aM <sup>(1)</sup> / max. rating (A)	800	800	800
		Isc max. kA rms	100	100	100
		Making capacity kA peak	220	220	220
Type gG <sup>(2)</sup> / max. rating (A)		315	400	500	
Isc max. kA rms		100	100	100	
Making capacity kA peak		220	220	220	
Type gG <sup>(1)</sup> / max. rating (A)		630	630	500/630	
Isc max. kA rms		50	50	100/50	
Making capacity kA peak		105	105	220/105	

(1) Mandatory protection by an external thermal relay.  
 (2) No external thermal relay.

# Protection of switch-disconnectors

## INS40 to 2500 and INV100 to 2500 by fuses

	INS100	INS125	INS160	INS250-100 INV100	INS250-160 INV160	INS250-200 INV200	INS/INV250	INS/INV320
	200 100 220	200 100 220	200 100 220	315 100 220	315 100 220	315 100 220	315 100 220	800 100 220
	80 100 220	100 100 220	125 100 220	80 100 220	125 100 220	160 100 220	200 100 220	250 100 220
	125/160 100/50 220/105	125/160 100/50 220/105	125/160 100/50 220/105	225/355 100/50 220/105	225/355 100/50 220/105	225/355 100/50 220/105	225/355 100/50 220/105	630 50 105
	80 & 63M80 80 176	100 & 63M100 80 176	125 & 100M125 80 176	80 & 63M80 80 176	125 & 100M125 80 176	160 & 100M160 80 176	200 & 100M200 80 176	250 & 200M250 80 176
	160 & 100M160 80 176	160 & 100M160 80 176	160 & 100M160 80 176	250 & 200M250 80 176	250 & 200M250 80 176	250 & 200M250 80 176	250 & 200M250 80 176	355 & 315M355 80 176

	INS/INV630b	INS/INV800	INS/INV1000	INS/INV1250	INS/INV1600	INS/INV2000	INS/INV2500
	1000/1250 100 220	1000/1250 100 220	1000/1250 100 220	1000/1250 100 220	1000/1250 100 220	-	-
	500 100 220	630 100 220	800 100 220	1000 80 176	1000/1250 80/50 176/105	-	-
	1000/1250 80/50 176/105	1000/1250 80/50 176/105	1000/1250 80/50 176/105	1000/1250 80/50 176/105	1000/1250 80/50 176/105	-	-
	500 80 176	630 80 176	800 80 176	1000 80 176	1000/1250 80/50 176/105	-	-
	1000/1250 80/50 176/105	1000/1250 80/50 176/105	1000/1250 80/50 176/105	1000/1250 80/50 176/105	1000/1250 80/50 176/105	-	-
	1000/1250 100 220	1000/1250 100 220	1000/1250 100 220	1000/1250 100 220	1000/1250 100 220	-	-
	500 100 220	630 100 220	800 100 220	1000 80 176	1000/1250 80/50 176/105	-	-
	1000/1250 80/50 176/105	1000/1250 80/50 176/105	1000/1250 80/50 176/105	1000/1250 80/50 176/105	1000/1250 80/50 176/105	-	-

# Characteristics of switch-disconnectors

## INS40 to 2500 and INV100 to 2500 for direct current

### Parallel connection of poles

Maximum permissible current at 60 °C			
	Rating (A)	In max 3P parallel	In max 4P parallel
INS	40	96	128
	63	151	202
	80	192	256
INS/INV	100	240	320
	125	300	400
	160	384	512
	200	480	640
	250	600	800
	320	768	1024
	400	960	1280
	500	1200	1600
	630	1512	2016
	800	1920	2560
	1000	2400	3200
	1250	3000	4000
	1600	3840	5120
	2000	4800	6400
	2500	6000	8000





## schneider-electric.com

This international site allows you to access all the Schneider Electric products in just 2 clicks via comprehensive range data-sheets, with direct links to:

- complete library: technical documents, catalogs, FAQs, brochures...

- selection guides from the e-catalog.

- product discovery sites and their Flash animations.

You will also find illustrated overviews, news to which you can subscribe, the list of country contacts...



## The technical guide

These technical guides help you comply with installation standards and rules i.e.: the electrical installation guide, the protection guide, the switchboard implementation guide, the technical booklets and the co-ordination tables all form genuine reference tools for the design of high performance electrical installations.

For example, the LV protection co-ordination guide - discrimination and cascading - optimises choice of protection and connection devices while also increasing markedly continuity of supply in the installations.



<i>Presentation</i>	2
<i>Functions and characteristics</i>	A-1
<i>Installation recommendations</i>	B-1
<i>Dimensions and connection</i>	C-1
<i>Additional characteristics</i>	D-1
<b>INS40 to 160</b>	<b>E-2</b>
Complete fixed/FC device and accessories	E-2
Accessories	E-3
<b>INS250-100 to 630</b>	<b>E-5</b>
Complete fixed/FC device and accessories	E-5
<b>INV100 to 630</b>	<b>E-6</b>
Complete fixed/FC device and specific accessories	E-6
<b>INS250-100 to 250 and INV100 to 250</b>	<b>E-7</b>
Accessories	E-7
<b>INS320 to 630 and INV320 to 630</b>	<b>E-10</b>
Accessories	E-10
<b>INS630b to 2500</b>	<b>E-12</b>
Complete fixed/FC device and accessories	E-12
<b>INS630b to 2500 and INV630b to 2500</b>	<b>E-14</b>
Accessories	E-14
<b>INSE80 (40 to 80 A) molded case switch UL489/ CSA C22-2 N° 5.2</b>	<b>E-16</b>
Complete fixed/FC device and accessories	E-16
<b>INSJ400 (250 to 400 A) molded case switch UL489/ CSA C22-2 N° 5.2</b>	<b>E-18</b>
Complete fixed/FC device and accessories	E-18

# INS40 to 160

## Complete fixed/FC device and accessories

### Interpact INS40 to 160 standard version with black handle

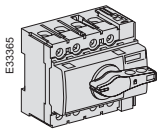

	3P	4P
Interpact INS40	28900	28901
Interpact INS63	28902	28903
Interpact INS80	28904	28905

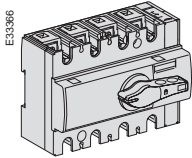

	3P	4P
Interpact INS100	28908	28909
Interpact INS125	28910	28911
Interpact INS160	28912	28913

### Interpact INS40 to 160 with red handle and yellow front

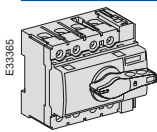

	3P	4P
Interpact INS40	28916	28917
Interpact INS63	28918	28919
Interpact INS80	28920	28921

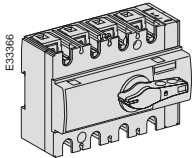

	3P	4P
Interpact INS100	28924	28925
Interpact INS125	28926	28927
Interpact INS160	28928	28929

### Individual enclosures

#### IP55 heavy-duty sheetmetal enclosure

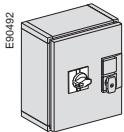

For INS40 to INS160 with extended standard rotary handle	31208
For INS40 to INS160 with extended red handle on yellow front	31209

#### IP55 heavy-duty insulating enclosure

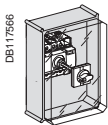

For INS40 to INS160 with extended standard rotary handle	28967
For INS40 to INS160 with extended red handle on yellow front	28968

### Connection accessories

#### Distribloc distribution block (for bare cables)

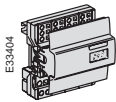

INS40 to 125	125 A, 12 outgoing spring terminals (7 x 4 mm <sup>2</sup> + 3 x 6 mm <sup>2</sup> + 2 x 10 mm <sup>2</sup> ) + 1 outgoing tunnel terminal (35 mm <sup>2</sup> ) <sup>(1)</sup>	04045
	4 prefabricated connections 125 A, 35 mm <sup>2</sup> , l = 210 mm <sup>(1)</sup>	04047
INS100 to 160	160 A, 12 outgoing spring terminals (7 x 4 mm <sup>2</sup> + 3 x 6 mm <sup>2</sup> + 2 x 10 mm <sup>2</sup> ) + 1 outgoing tunnel terminal (35 mm <sup>2</sup> ) w h	04046
	4 prefabricated connections <sup>(1)</sup>	

#### Multi-stage distribution block (for bare cables)

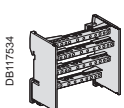



INS40 to 125	40 A, 4 x 13 holes (11 x 10 mm <sup>2</sup> + 2 x 16 mm <sup>2</sup> ) <sup>(1)</sup>	13508
	100 A, 4 x 7 holes (3 x 10 mm <sup>2</sup> + 3 x 16 mm <sup>2</sup> + 1 x 25 mm <sup>2</sup> ) <sup>(1)</sup>	13510
	125 A, 4 x 13 holes (5 x 10 mm <sup>2</sup> + 5 x 16 mm <sup>2</sup> + 2 x 25 mm <sup>2</sup> + 1 x 35 mm <sup>2</sup> ) <sup>(1)</sup>	13512
	125 A, 4 x 17 holes (7 x 10 mm <sup>2</sup> + 7 x 16 mm <sup>2</sup> + 2 x 25 mm <sup>2</sup> + 1 x 35 mm <sup>2</sup> ) <sup>(1)</sup>	13514
Additional neutral bar	40 A, L = 89 mm <sup>(1)</sup>	13516
	100 A, L = 62 mm <sup>(1)</sup>	13515
	125 A, L = 107 mm <sup>(1)</sup>	13517
	125 A, L = 134 mm <sup>(1)</sup>	13518

(1) Product sold by MGA.

## Connection accessories (cont.)

### Connectors for bare Cu or Al cables

DB117569 	Snap-on	INS100 to 160 S ≤ 95 mm <sup>2</sup>	Set of 3	28947
			Set of 4	28948
DB117560 	Distribution connector for 3 rigid cables up to 16 mm <sup>2</sup> or 3 flexible cables up to 10 mm <sup>2</sup>	INS40 to 80	Set of 3	19096
			Set of 4	19091
DB117561 	Distribution connector for 4 rigid cables up to 25 mm <sup>2</sup> or 4 flexible cables up to 16 mm <sup>2</sup>	INS100 to 160	Set of 3	28949
			Set of 4	28950

### Crimp lugs for copper cables

DB117562 	For 95 mm <sup>2</sup> cables with interphase barriers	INS100 to 160	Set of 3	28951
			Set of 4	28952

### Terminal shrouds

DB117592 	INS40 to 80	3P/4P	Set of 2	28955
	INS100 to 160	3P/4P	Set of 2	28956

### Terminal shields

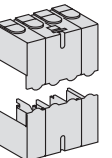
DB117593 	INS40 to 80	3P/4P	Set of 2	28957
	INS100 to 160	3P/4P	Set of 2	28958

### Interphase barriers

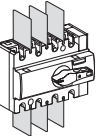
E88893 	INS100 to 160	3P/4P	Set of 6	28959
---	---------------	-------	----------	-------



## Electrical auxiliaries

### Auxiliary contacts

DB117563 	1 OF / CAF / CAO (standard)	INS40 to 160	29450
	1 OF / CAF / CAO (low level)	INS40 to 160	29452

## Rotary handles

### Accessories for conversion to extended rotary handles

E33405 	Front control	Black handle	INS40 to 160	28941
		Red handle on yellow front	INS40 to 160	28942
E51011 	Lateral control	Black handle	INS40 to 160	28943
		Red handle on yellow front	INS40 to 160 <sup>(1)</sup>	28944
	Lateral control on G, GX or PRAGMA F functional enclosure	Black handle	INS40 to 160	28945
		Red handle on yellow front	INS40 to 160 <sup>(1)</sup>	28946

(1) For red/yellow switch versions only.

**Locking and interlocking**

**Handle locking**

By 1 to 3 padlocks (OFF position), hasp dia. 5 to 8 mm, or by lead seals

**Built-in**

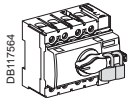

**Interlocking for extended rotary handles**

Mechanical

**28953**

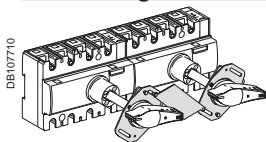

**Spare parts**

Black handle  
Red handle

**28962**  
<sup>(1)</sup> **28963**



<sup>(1)</sup> For red/yellow switch versions only.

# INS250-100 to 630

## Complete fixed/FC device and accessories

### Interpact INS250 to 630 standard version with black handle

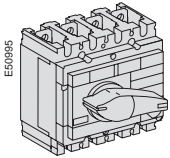

	3P	4P
Interpact INS250-100A	31100	31101
Interpact INS250-160A	31104	31105
Interpact INS250-200A	31102	31103
Interpact INS250	31106	31107

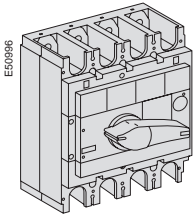

	3P	4P
Interpact INS320	31108	31109
Interpact INS400	31110	31111
Interpact INS500	31112	31113
Interpact INS630	31114	31115

### Interpact INS250 to 630 with red handle and yellow front

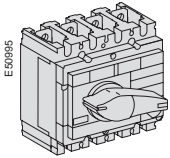

	3P	4P
Interpact INS250-100A	31120	31121
Interpact INS250-160A	31124	31125
Interpact INS250-200A	31122	31123
Interpact INS250	31126	31127

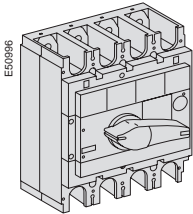

	3P	4P
Interpact INS320	31128	31129
Interpact INS400	31130	31131
Interpact INS500	31132	31133
Interpact INS630	31134	31135

### Source changeover systems

#### Complete assembly

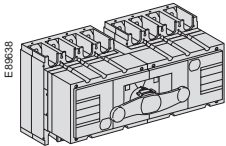

	3P	4P
With Interpact INS250-100A	31140	31141
With Interpact INS250-160A	31144	31145
With Interpact INS250-200A	31142	31143
With Interpact INS250	31146	31147
With Interpact INS320	31148	31149
With Interpact INS400	31150	31151
With Interpact INS500	31152	31153
With Interpact INS630	31154	31155

#### Downstream coupling accessories

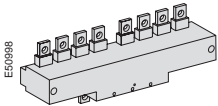

	3P	4P
For Interpact INS250	29358	29359
Long downstream 3P/4P terminal shields (set of 2)		29324
For Interpact INS320 to 630	32619	32620
Long downstream 3P/4P terminal shields (set of 2)		32583

### Individual enclosures

#### IP55 heavy-duty sheetmetal enclosure

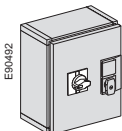

For INS250-100 to 250 with extended standard rotary handle	31210
For INS250-100 to 250 with extended red rotary handle on yellow front	31211
For INS320 to 630 with extended standard rotary handle	31212
For INS320 to 630 with extended red rotary handle on yellow front	31213

#### IP55 heavy-duty insulating enclosure

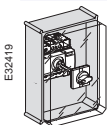

For INS250-100 to 250 with extended standard rotary handle	31204
For INS250-100 to 250 with extended red rotary handle on yellow front	31205
For INS320 to 630 with extended standard rotary handle	31206
For INS320 to 630 with extended red rotary handle on yellow front	31207

### Interpact INV100 to 630 standard version with black handle

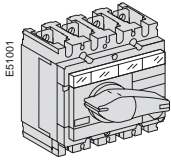

	3P	4P
Interpact INV100	31160	31161
Interpact INV160	31164	31165
Interpact INV200	31162	31163
Interpact INV250	31166	31167

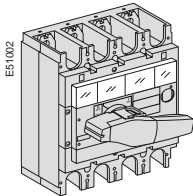

	3P	4P
Interpact INV320	31168	31169
Interpact INV400	31170	31171
Interpact INV500	31172	31173
Interpact INV630	31174	31175

### Interpact INV100 to 630 with red handle and yellow front

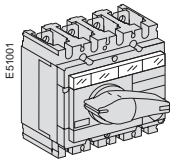

	3P	4P
Interpact INV100	31180	31181
Interpact INV160	31184	31185
Interpact INV200	31182	31183
Interpact INV250	31186	31187

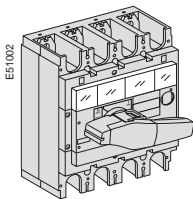

	3P	4P
Interpact INV320	31188	31189
Interpact INV400	31190	31191
Interpact INV500	31192	31193
Interpact INV630	31194	31195

### Individual enclosures

#### IP55 heavy-duty insulating enclosure

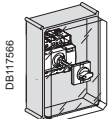

For INV100 to 250 with extended standard rotary handle	31204
For INV100 to 250 with extended red rotary handle on yellow front	31205
For INV320 to 630 with extended standard rotary handle	31206
For INV320 to 630 with extended red rotary handle on yellow front	31207

### Combination with Compact NS devices for "tarif jaune / tarif vert"

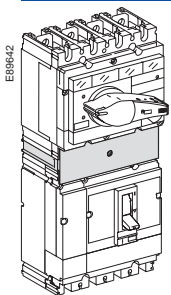

INV100 to 250 combination with NS250	31066
INV320 to 630 combination with NS250	31067
Front alignment base for INV320 to 630 combination with NS250	31064
INV320 to 630 combination with NS400/630	31068

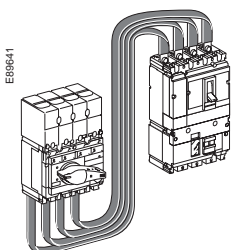

Flexible connection assembly for vertical INV100 to 250 with horizontal NS250	04443
Flexible connection assembly for vertical INV100 to 250 with horizontal Vigì NS250	04444
Flexible connection assembly for vertical INV320 to 630 with horizontal NS250/400/630	04445
Flexible connection assembly for vertical INV320 to 630 with horizontal Vigì NS250/400/630	04446
Flexible connection assembly for vertical INV100 to 250 with horizontal NS250	31069
Flexible connection assembly for vertical INV320 to 400 with horizontal NS250	31092
Flexible connection assembly for vertical INV100 to 250 with vertical NS250 beside	31071
Flexible connection assembly for vertical INV320 to 630 with vertical NS400/630 beside	31072
Flexible connection assembly for vertical INV320 to 630 with vertical NS250 beside	31093

(1) Product sold by MGA and valid for new Prisma Plus only.

(2) Product sold by MGA suitable for old Prisma range.





## Connection accessories

### Rear connections

	Short (1 pair)			29235
	Long (1 pair)			29236

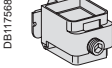

### Bare cable connectors

	Snap-on, for cables:	Steel: 1.5 to 95 mm <sup>2</sup> ; ≤ 160 A	Set of 3	29242
			Set of 4	29243
		Aluminium: 25 to 95 mm <sup>2</sup> ; ≤ 250 A	Set of 3	29227
			Set of 4	29228
	Tab connector for voltage tap on 185 mm <sup>2</sup> bare cable connector		Set of 2	29348
		Clip for bare cable connector	Set of 10	29241
		Distribution connector for six 1.5 to 35 mm <sup>2</sup> cables with interphase barriers	Set of 3	29248
			Set of 4	29249

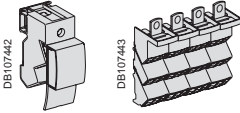
### Polybloc distribution block (for bare cables)

	160 A	For 6 cables (10 mm <sup>2</sup> ) per pole	1P	04031
	250 A	For 9 cables (6 x 10 mm <sup>2</sup> + 3 x 16 mm <sup>2</sup> ) per pole	3P	04033
			4P	04034
		Additives blocks of 2 x 35 mm <sup>2</sup> per pole	3P	04155
			4P	04156

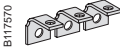
### Terminal extensions (supplied with 2 or 3 interphase barriers)

	Right-angle terminal extensions		Set of 3	29261
			Set of 4	29262
	Straight terminal extensions		Set of 3	29263
			Set of 4	29264

### Spreaders (for upstream or downstream connection)

	Separate for each pole	3P	3P	31563
		4P	4P	31564
	One-piece Front alignment base for one-piece spreader	3/4 P	3/4P	31061
		3/4 P	3/4P	31064

### Crimp lugs for copper cables (supplied with 2 or 3 interphase barriers)

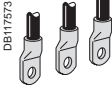
	For 120 mm <sup>2</sup> cables		Set of 3	29252
			Set of 4	29256
	For 150 mm <sup>2</sup> cables		Set of 3	29253
			Set of 4	29257
	For cable 185 mm <sup>2</sup> cables		Set of 3	29254
			Set of 4	29258

### Crimp lugs for aluminium cables (supplied with 2 or 3 interphase barriers)

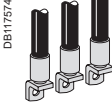
	For 150 mm <sup>2</sup> cables		Set of 3	29504
			Set of 4	29505
	For 185 mm <sup>2</sup> cables		Set of 3	29506
			Set of 4	29507

### Terminal shields

	Short	3/4 P	Set of 2	29322
	Long	3/4 P	Set of 2	29324

### Interphase barriers

			Set of 6	29329
---	--	--	----------	-------

(1) Product sold by MGA.

## Special connection accessories for INS250-100 to 250DC and INV100 to 250DC

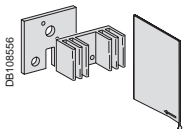
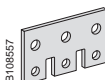
	Terminal extensions for series or parallel connection of two poles (*)	1 terminal ext.	<b>29498</b>
	(*) <i>Series connection of:</i>	2 poles = 1 terminal extension	
		3 poles = 2 terminal extensions	
		4 poles = 3 terminal extensions	
	<i>Parallel connection of:</i>	2 poles = 2 terminal extensions	
		3 poles = set of 2 terminal extensions (29499)	
		4 poles = 4 terminal extensions	
	Terminal extensions for parallel connection of three poles	Set of 2 terminal extensions	<b>29499</b>
	4P terminal shields for series connection of poles	Set of 1	<b>29496</b>
	4P terminal shields for parallel connection of poles (2P/4P)	Set of 1	<b>29497</b>

## Electrical auxiliaries

### Auxiliary contacts (changeover type)

	OF or CAM (early make or break)		<b>29450</b>
	Low level OF or CAM (early make or break)		<b>29452</b>

## Indication and measurement modules

### Ammeter module (4P)

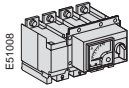
	Adaptation kit (compulsory for devices with direct front handles)		<b>31081</b>
	Rating (A)	100	<b>29456</b>
		150	<b>30556</b>
		250	<b>31566</b>

### Current transformer module and voltage output (4P)

	Rating (A)	100	<b>29462</b>
		150	<b>30562</b>
		250	<b>31570</b>

### Current transformer module (4P)

	Rating (A)	100	<b>29458</b>
		150	<b>30558</b>
		250	<b>31568</b>

### Voltage presence indicator

	Rating (A)	250	<b>29325</b>
--	------------	-----	--------------

## Rotary handles

### Extended front control

	For INS250 with standard rotary handle		<b>31050</b>
	For INS250 with red handle on yellow front	(1)	<b>31051</b>
	For complete source changeover assembly		<b>31055</b>

### Lateral control

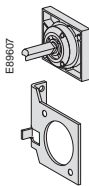
	<b>Direct lateral control for INS and INV250</b>		
	Lateral support		<b>31054</b>
	+ standard lateral control assembly		<b>31057</b>
	or + red and yellow lateral control assembly	(1)	<b>31058</b>
	<b>Extended lateral control for INS and INV250</b>		
	Standard lateral control assembly		<b>31057</b>
Red and yellow lateral control assembly	(1)	<b>31058</b>	

(1) For red/yellow switch versions only.

## Locking and interlocking for INS/INV and source changeover systems

### Locking for INS/INV

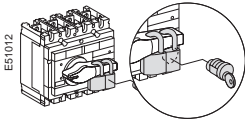

Handle locking by 1 to 3 padlocks (in OFF position)	<b>Built-in</b>
By keylock	<b>31087</b>
Keylocking device	<b>41940</b>
+ Ronis 1351B.500 keylock	<b>42888</b>
or + Profalux KS5 B24 D4Z keylock	

### Locking for INS complete source changeover assembly

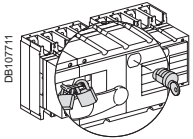

Handle locking by 1 to 3 padlocks (in OFF position)	<b>Built-in</b>
By keylock	<b>31097</b>
Keylocking device	<b>41940</b>
+ Ronis 1351B.500 keylock	<b>42888</b>
or + Profalux KS5 B24 D4Z keylock	

### Interlocking with key (2 keylocks / 1 key)

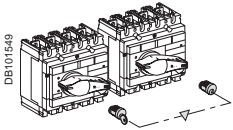

By 2 keylocks	INS250 keylocking device	2 x	<b>31087</b>
	INS320-600 keylocking device	2 x	<b>31088</b>
	+ Ronis 1351B.500 keylock		<b>41950</b>
	or + Profalux KS5 B24 D4Z keylock		<b>42878</b>

### Interlocking for INS/INV with direct or extended rotary handle

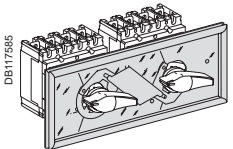

Mechanical interlocking for INS250	<b>31073</b>
------------------------------------	--------------

## Installation accessories

### Front panel escutcheons

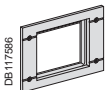

For INS/INV	<b>31079</b>
For ammeter module, IP40	<b>29318</b>

### Lead seal accessories

**29375**

## Spare parts

12 snap-in nuts for fixed/FC(M8)	<b>30554</b>
100 identification labels	<b>29314</b>
Bag of screws	<b>29312</b>
Black handle	<b>31082</b>
Red handle	<sup>(1)</sup> <b>31083</b>
Viewport for INV100/160/250	<b>31089</b>

(1) For red/yellow switch versions only.

## Connection accessories

### Rear connections

	Short (1 pair)			32475
	Long (1 pair)			32476

### Bare cable connectors

	For 1 cable, 35 mm <sup>2</sup> to 300 mm <sup>2</sup>		Set of 3	32479
			Set of 4	32480
	For 2 cables, 35 mm <sup>2</sup> to 240 mm <sup>2</sup>		Set of 3	32481
			Set of 4	32482
	Tab connector for voltage tap on bare cable connector		Set of 2	29348

### Terminal extensions (supplied with 2 or 3 interphase barriers)

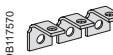
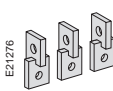
	Right-angle terminal extensions		Set of 3	32484
			Set of 4	32485
	Edgewise terminal extensions		Set of 3	32486
			Set of 4	32487

### Spreaders (for upstream or downstream connection)

	One-piece	52.5 mm	3P	32490
			4P	32491
		70 mm	3P	32492
			4P	32493

### Crimp lugs for copper cables (supplied with 2 or 3 interphase barriers)

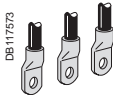
	For 240 mm <sup>2</sup> cables		Set of 3	32500
			Set of 4	32501
	For 300 mm <sup>2</sup> cables		Set of 3	32502
			Set of 4	32503

### Crimp lugs for aluminium cables (supplied with 2 or 3 interphase barriers)

	For 240 mm <sup>2</sup> cables		Set of 3	32504
			Set of 4	32505
	For 300 mm <sup>2</sup> cables		Set of 3	32506
			Set of 4	32507

### Terminal shields

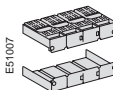
	Short	3/4P	Set of 2	32563
	Long	3/4P	Set of 2	32565
	Long for 52.5 mm spreader (supplied with insulating plate)	3/4P	Set of 2	32583

### Interphase barriers

			Set of 6	32570
--	--	--	----------	-------

### Special connection accessories for INS/INV320 to 630DC

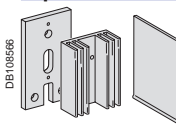
	Terminal extensions for series or parallel connection of two poles (*)		1 terminal ext.	32868
	(*) Series connection of: 2 poles = 1 terminal extension 3 poles = 2 terminal extensions 4 poles = 3 terminal extensions			
	Parallel connection of: 2 poles = 2 terminal extensions 4 poles = 4 terminal extensions			
	4P terminal shields for series connection of poles		Set of 1	32866
4P terminal shields for parallel connection of poles		Set of 1	32867	

## Electrical auxiliaries

### Auxiliary contacts (changeover type)

	OF or CAM (early make or break)	29450
	OF or CAM low level (early make or break)	29452

## Indication and measurement modules

### Ammeter module (4P)

	Rating (A)	400	32656
		600	32856

### Current transformer module (4P)

	Rating (A)	400	32658
		600	32858

### Voltage presence indicator

	Rating (A)	630	32566
---	------------	-----	-------

## Rotary handles

### Extended front control

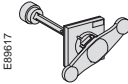
	For INS320/400/630 with standard rotary handle	31052
	For INS320/400/630 with red handle on yellow front	(1) 31053
	For complete source changeover assembly	31055

## Locking and interlocking for INS/INV and source changeover systems

### Locking for INS/INV

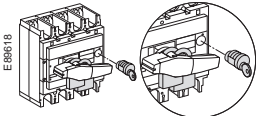
	Handle locking by 1 to 3 padlocks (in OFF position)	<b>Built-in</b>
	By keylock	31088
	Keylocking device + Ronis 1351B.500 keylock	41940
	or + Profalux KS5 B24 D4Z keylock	42888

### Locking for INS complete source changeover assembly

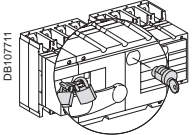
	Handle locking by 1 to 3 padlocks (in OFF position)	<b>Built-in</b>
	By keylock	31097
	Keylocking device + Ronis 1351B.500 keylock	41940
	or + Profalux KS5 B24 D4Z keylock	42888

### Interlocking with key (2 keylocks / 1 key)

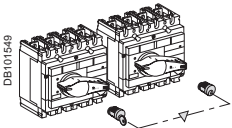
	By 2 keylocks	INS250 keylocking device	2 x	31087
		INS320-600 keylocking device	2 x	31088
		+ Ronis 1351B.500 keylock		41950
		or + Profalux KS5 B24 D4Z keylock		42878

### Interlocking for INS/INV with direct or extended rotary handle

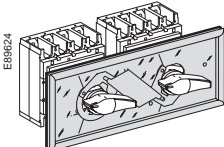
	Mechanical interlocking for INS320/400/630	31074
---	--	-------

## Installation accessories

### Front panel escutcheons

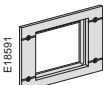
	For INS/INV	31080
	For ammeter module, IP40	29318

### Lead seal accessories

		29375
--	--	-------

## Spare parts

100 labels	29314
Bag of screws	32552
Black handle	31084
Red handle	(1) 31085
Viewport for INV320/400/630	31090

(1) For red/yellow switch versions only.

# INS630b to 2500

Complete fixed/FC device  
and accessories

## Interpact INS630b to 2500 standard version with black handle

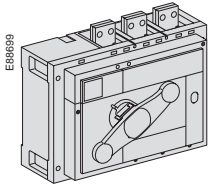

	3P	4P
Interpact INS630b	31342	31343
Interpact INS800	31330	31331
Interpact INS1000	31332	31333
Interpact INS1250	31334	31335
Interpact INS1600	31336	31337

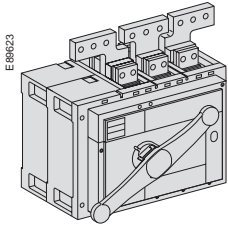

Interpact INS2000	31338	31339
Interpact INS2500	31340	31341

## Interpact INS630b to 1600 with red handle and yellow front

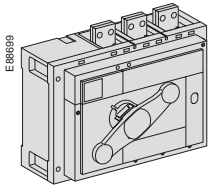

	3P	4P
Interpact INS630b	31356	31357
Interpact INS800	31344	31345
Interpact INS1000	31346	31347
Interpact INS1250	31348	31349
Interpact INS1600	31350	31351

# INV630b to 2500

Complete fixed/FC device  
and specific accessories

## Interpact INV630b to 2500 standard version with black handle

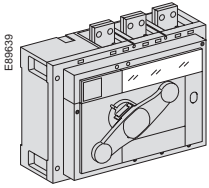

	3P	4P
Interpact INV630b	31370	31371
Interpact INV800	31358	31359
Interpact INV1000	31360	31361
Interpact INV1250	31362	31363
Interpact INV1600	31364	31365

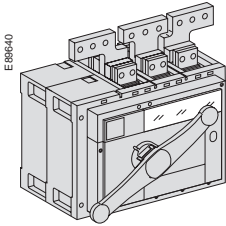

Interpact INV2000	31366	31367
Interpact INV2500	31368	31369

## Interpact INV630b to 1600 with red handle and yellow front

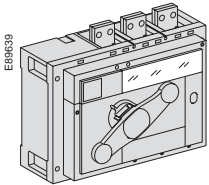

	3P	4P
Interpact INV630b	31387	31388
Interpact INV800	31372	31373
Interpact INV1000	31374	31375
Interpact INV1250	31376	31377
Interpact INV1600	31378	31379

## Combination with Compact NS devices (for "tarif vert")

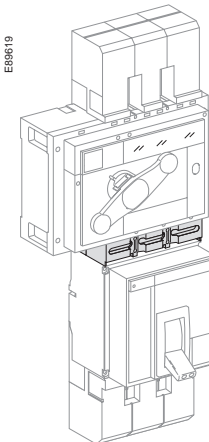

	3P	4P
INV630b/1000/1250 combination with NS800/1000/1250	31385	31386

## Connection accessories

### Vertical connection adapters

	INS/INV630b-1600	3P	Set of 3	31301
		4P	Set of 4	31302

### Cable lug adapters

	INS/INV630b-1600	3P	Set of 3	33644
		4P	Set of 4	33645

### Spreaders

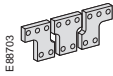
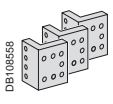
	INS/INV630b-1600	3P	Set of 3	31305
		4P	Set of 4	31306
	Connector for direct connection (edgewise or flat) to INS2000/2500			31310

## Special connection accessories for INS/INV 630b to INS 1600 DC

	Terminal extensions for series connection for DC INS630b/1600			31320
--	---	--	--	-------

## Insulation accessories

### Base for terminal shield (not compatible with interphase barriers)

	INS/INV630b-1600	3P		31307
		4P		31308

### Terminal shield

	INS/INV630b-1600	3P		33628
		4P		33629

### Interphase barriers (not compatible with terminal shield and base)

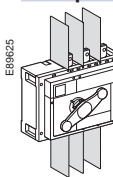
	INS/INV630b-1600	4P	Set of 6	31315
	INS/INV2000/2500	4P	Set of 6	31319

## Electrical auxiliaries

### Auxiliary contacts (changeover type) INS/INV630b-2500

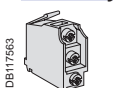
	OF or CAM (early make or break)			29450
	OF or CAM low level (early make or break)			29452

### Extended front control

	INS/INV630b-2500	For standard rotary handle		31288
	INS/INV630b-1600	For red handle on yellow front	(1)	31289

(1) For red/yellow switch versions only.



## Locking and interlocking

### Locking for INS/INV630b to 2500

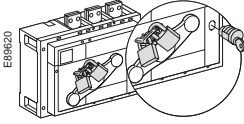

Handle locking by 1 to 3 padlocks (in OFF position)	<b>Built-in</b>
By keylock	<b>31291</b>
Keylocking device	<b>41940</b>
+ Ronis 1351B.500 keylock	<b>42888</b>
or + Profalux KS5 B24 D4Z keylock	

### Interlocking for INS/INV630b to 2500

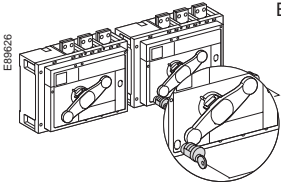

By keylock	Keylocking device	2 x	<b>31291</b>
	+ Ronis 1351B.500 keylock (1 keylocks / 1 key)		<b>41950</b>
	or + Profalux KS5 B24 D4Z keylock (1 keylocks / 1 key)		<b>42878</b>

## Installation accessories

### Escutcheon

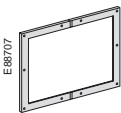

INS630b-2500	3P/4P	<b>31295</b>
--------------	-------	--------------

### Lead seal accessories

**31316**

## Spare parts



INS/INV630b-1600	Black handle	<b>31296</b>
	Red handle	<sup>(1)</sup> <b>31297</b>
INS/INV2000-2500	Black handle	<b>31298</b>

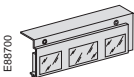

Viewport for INV630b/2500	3P	<b>31293</b>
	4P	<b>31294</b>

<sup>(1)</sup> For red/yellow switch versions only.

# INSE80 (40 to 80 A) molded case switch UL489/CSA C22-2 N° 5.2

## Complete fixed/FC device and accessories

### Interpact INSE80 (40 to 80 A) standard version with black handle

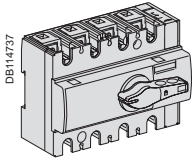

Interpact INSE80	40 A	3P	28994	4P	28995
	60 A		28996		28997
	80 A		28998		28999

### Individual enclosures

#### IP55 heavy-duty sheetmetal enclosure<sup>(1)</sup>

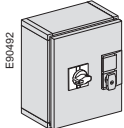

For INSE80-40 A to INSE80-80 A with extended standard rotary handle	31208
For INSE80-40 A to INSE80-80 A with extended red handle on yellow front	31209

#### IP55 heavy-duty insulating enclosure<sup>(1)</sup>

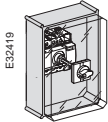

For INSE80-40 A to INSE80-80 A with extended standard rotary handle	28967
For INSE80-40 A to INSE80-80 A with extended red handle on yellow front	28968

### Connection accessories

#### Distribloc distribution block (for bare cables)

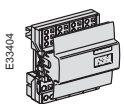

INSE80-40 A to INSE80-80 A <sup>(1)</sup>	160 A, 12 outgoing spring terminals (7 x 4 mm <sup>2</sup> + 3 x 6 mm <sup>2</sup> + 2 x 10 mm <sup>2</sup> ) + 1 outgoing tunnel terminal (25 mm <sup>2</sup> ) with prefabricated connections	<sup>(2)</sup>	07106
---	---	----------------	-------

#### Multi-stage distribution block (for bare cables)

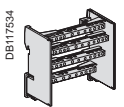

INSE80-40 A to INSE80-80 A <sup>(1)</sup>	125 A, 4 x 10 holes (5 x 10 mm <sup>2</sup> + 4 x 16 mm <sup>2</sup> + 1 x 35 mm <sup>2</sup> )	<sup>(2)</sup>	13512
	125 A, 4 x 17 holes (8 x 10 mm <sup>2</sup> + 8 x 16 mm <sup>2</sup> + 1 x 35 mm <sup>2</sup> )	<sup>(2)</sup>	13514

#### Connectors for bare Cu or Al cables



Snap-on	INSE80-40 A to INSE80-80 A 1.5 to 95 mm <sup>2</sup> 12 AWG to 3/0 AWG C4/AL	Set of 3	28947
		Set of 4	28948



Distribution connector for 4 rigid cables up to 25 mm <sup>2</sup> or 4 flexible cables up to 16 mm <sup>2</sup>	INSE80-40 A to INSE80-80 A <sup>(1)</sup>	Set of 3	28949
		Set of 4	28950

#### Crimp lugs for copper cables<sup>(1)</sup>



For 95 mm <sup>2</sup> cables with interphase barriers	INSE80-40 A to INSE80-80 A	Set of 3	28951
		Set of 4	28952

#### Terminal shrouds

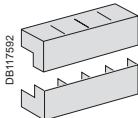

INSE80-40 A to INSE80-80 A	3P/4P	Set of 2	28956
----------------------------	-------	----------	-------

#### Terminal shields

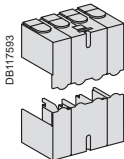

INSE80-40 A to INSE80-80 A	3P/4P	Set of 2	28958
----------------------------	-------	----------	-------

(1) Not UL Listed.  
(2) Product sold by MGA.

# INSE80 (40 to 80 A) molded case switch UL489/CSA C22-2 N° 5.2

Complete fixed/FC device and accessories (cont.)

## Connection accessories (cont.)

### Interphase barriers

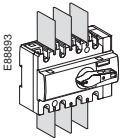
	INSE80-40 A to INSE80-80 A	3P/4P	Set of 6	<b>28959</b>
---	----------------------------	-------	----------	--------------

## Electrical auxiliaries

### Auxiliary contacts

	1 OF / CAF / CAO (standard)	INSE80-40 A to INSE80-80 A	<b>29450</b>
	1 OF / CAF / CAO (low level)	INSE80-40 A to INSE80-80 A	<b>29452</b>

## Rotary handles

### Accessories for conversion to extended rotary handles

	Front control	Black handle	INSE80-40 A to INSE80-80 A	<b>28941</b>
		Red handle on yellow front	INSE80-40 A to INSE80-80 A	<b>28942</b>
	Lateral control	Black handle	INSE80-40 A to INSE80-80 A	<b>28943</b>
		Red handle on yellow front + red handle <sup>(2)</sup>	INSE80-40 A to INSE80-80 A	<b>28944</b>
	Lateral control on G, GX or PRAGMA F functional enclosure	Black handle	INSE80-40 A to INSE80-80 A	<b>28945</b>
		Red handle on yellow front <sup>(2)</sup>	INSE80-40 A to INSE80-80 A	<b>28946</b>

## Locking and interlocking

### Handle locking

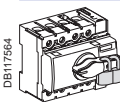
	By 1 to 3 padlocks (OFF position), hasp dia. 5 to 8 mm, or by lead seals	<b>Built-in</b>
---	--	-----------------

### Interlocking for extended rotary handles

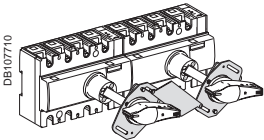
	Mechanical <sup>(1)</sup>	<b>28953</b>
---	---------------------------	--------------

## Spare parts

	Black handle	<b>28962</b>
	Red handle <sup>(2)</sup>	<b>28963</b>

<sup>(1)</sup> Not UL listed.

<sup>(2)</sup> For red/yellow switch versions only.

# INSJ400 (250 to 400 A) molded case switch UL489/ CSA C22-2 N° 5.2

Complete fixed/FC device and accessories

## Interpact INSJ400 (250 A to 400 A) standard version with black handle

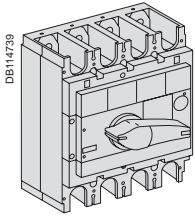

	<b>3P</b>	<b>4P</b>
Interpact INSJ400-250 A	<b>31118</b>	<b>31119</b>
Interpact INSJ400-400 A	<b>31136</b>	<b>31137</b>

## Individual enclosures

### IP55 heavy-duty sheetmetal enclosure <sup>(1)</sup>

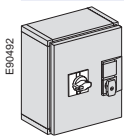

For INSJ400-250 to 400 A with extended standard rotary handle	<b>31212</b>
For INSJ400-250 to 400 A with extended red rotary handle on yellow front	<b>31213</b>

### IP55 heavy-duty insulating enclosure <sup>(1)</sup>

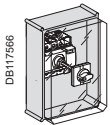

For INSJ400-250 to 400 A with extended standard rotary handle	<b>31206</b>
For INSJ400-250 to 400 A with extended red rotary handle on yellow front	<b>31207</b>

## Connection accessories

### Rear connections

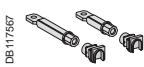

Short (1 pair)	<b>32475</b>
Long (1 pair)	<b>32476</b>

### Bare cable connectors



For 1 cable, 35 mm <sup>2</sup> to 300 mm <sup>2</sup>	Set of 3	<b>32479</b>
	Set of 4	<b>32480</b>
For 2 cables, 35 mm <sup>2</sup> to 240 mm <sup>2</sup>	Set of 3	<b>32481</b>
	Set of 4	<b>32482</b>



Tab connector for voltage tap on bare cable connector	Set of 2	<b>29348</b>
---	----------	--------------

### Terminal extensions (supplied with 2 or 3 interphase barriers)

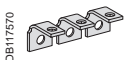

Right-angle terminal extensions	Set of 3	<b>32484</b>
	Set of 4	<b>32485</b>

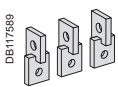

Edgewise terminal extensions	Set of 3	<b>32486</b>
	Set of 4	<b>32487</b>

### Spreaders (for upstream or downstream connection)

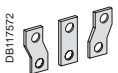

One-piece	52.5 mm	3P	<b>32490</b>
		4P	<b>32491</b>
	70 mm	3P	<b>32492</b>
		4P	<b>32493</b>

### Crimp lugs for copper cables (supplied with 2 or 3 interphase barriers) <sup>(1)</sup>

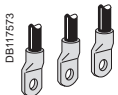

For 240 mm <sup>2</sup> cables	Set of 3	<b>32500</b>
	Set of 4	<b>32501</b>
For 300 mm <sup>2</sup> cables	Set of 3	<b>32502</b>
	Set of 4	<b>32503</b>

### Crimp lugs for aluminium cables (supplied with 2 or 3 interphase barriers) <sup>(1)</sup>

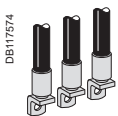

For 240 mm <sup>2</sup> cables	Set of 3	<b>32504</b>
	Set of 4	<b>32505</b>
For 300 mm <sup>2</sup> cables	Set of 3	<b>32506</b>
	Set of 4	<b>32507</b>

<sup>(1)</sup> Not UL Listed.

## Connection accessories (cont.)

### Terminal shields

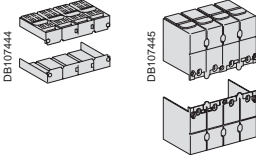
	Short	3/4P	Set of 2	32563
	Long	3/4P	Set of 2	32565
	Long for 52.5 mm spreader (supplied with insulating plate)	3/4P	Set of 2	32583

### Interphase barriers

			Set of 6	32570

## Electrical auxiliaries

### Auxiliary contacts (changeover type)

	OF or CAM (early make or break)			29450
	OF or CAM low level (early make or break)			29452

## Rotary handles

### Extended front control

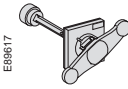
	For INSJ400-250 to 400 A with standard rotary handle			31052
	For INSJ400-250 to 400 A with red handle on yellow front + red handle <sup>(1)</sup>			31053
				31085

## Locking and interlocking and source changeover systems

### Locking

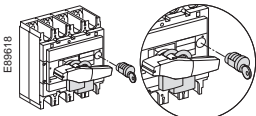
	Handle locking by 1 to 3 padlocks (in OFF position)			Built-in
	By keylock	Keylocking device		31088
		+ Ronis 1351B.500 keylock		41940
		or + Profalux KS5 B24 D4Z keylock		42888

### Interlocking with key (2 keylocks / 1 key)

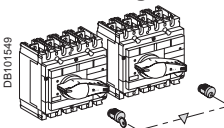
	By 2 keylocks	INSJ400-250 to 400 A keylocking device	2 x	31088
		+ Ronis 1351B.500 keylock		41950
		or + Profalux KS5 B24 D4Z keylock		42878

### Interlocking with direct or extended rotary handle

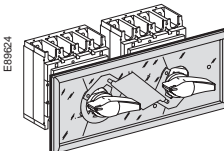
	Mechanical interlocking for INSJ400-250 to 400 A			31074

## Installation accessories

### Front panel escutcheons

				31080

### Lead seal accessories

				29375
--	--	--	--	-------

## Spare parts

100 labels		29314
Bag of screws		32552
Black handle		31084
Red handle		31085

(1) For red/yellow switch versions only.





**Schneider Electric Industries SAS**

35, rue Joseph Monier  
92500 Rueil-Malmaison  
France

<http://www.schneider-electric.com>

*As standards, specifications and designs change from time to time, please ask for confirmation of the information given in this publication.*



*This document has been printed on ecological paper.*

Design: Schneider Electric  
Photos: Schneider Electric  
Printed: Centre impression - made in France